

SWITEL

SWISS BRAND 

Notruftelefon
Téléphone de secours
Telefono per chiamate d'emergenza
Emergency telephone

POWERTEL TF 520



Bedienungsanleitung
Mode d'emploi
Istruzioni per l'uso
Operating Instructions

D

F

I

GB

SWITEL

POWERTEL TF 520

Bedienungsanleitung	3
Mode d'emploi	25
Istruzioni per l'uso	47
Operating Instructions	69
Declaration of Conformity	92

1	Sicherheitshinweise	4
2	Telefon in Betrieb nehmen	5
3	Bedienelemente	7
4	Wie bediene ich mein Telefon?	8
5	Telefonieren	9
6	Automatischer Notruf	12
7	Nebenstellenanlagen / Zusatzdienste ..	15
8	Menüstruktur	16
9	Telefonbuch	17
10	Anruf- und Wahlwiederholungsliste	19
11	Falls es Probleme gibt	21
12	Pflegehinweise / Garantie	22
13	Stichwortverzeichnis	23

Sicherheitshinweise

1 Sicherheitshinweise

Lesen Sie diese Bedienungsanleitung sorgfältig durch.

Bestimmungsgemäße Verwendung

Dieses Telefon ist geeignet für das Telefonieren innerhalb eines Telefonnetzes. Jede andere Verwendung gilt als nicht bestimmungsgemäß. Eigenmächtige Veränderungen oder Umbauten sind nicht zulässig. Öffnen Sie das Gerät in keinem Fall selbst und führen Sie keine eigenen Reparaturversuche durch.

Aufstellungsort

Vermeiden Sie Belastungen durch Rauch, Staub, Erschütterungen, Chemikalien, Feuchtigkeit, Hitze oder direkte Sonneneinstrahlung.

Netzteil



Achtung: Verwenden Sie nur das mitgelieferte Netzteil, da andere Netzteile das Telefon beschädigen können. Sie dürfen den Zugang zum Netzteil nicht durch Möbel oder andere Gegenstände versperren.

Hörgeräte kompatibel

Das Telefon ist über den Premium-Hörer vorzüglich auf Hörgeräte abgestimmt und mit den meisten am Markt befindlichen Hörgeräten kompatibel. Durch die Vielzahl der angebotenen Modelle kann keine einwandfreie Funktion mit jedem Hörgerät garantiert werden.



Achtung: Dieses Telefon kann sehr laute Lautstärken wiedergeben, wenn die Verstärkung aktiviert ist und der Lautstärkeregler auf Maximum steht. Große Vorsicht ist geboten beim Wechsel zwischen Benutzern mit normalem Gehör und vermindertem Gehör.

Entsorgung

Wollen Sie Ihr Gerät entsorgen, bringen Sie es zur Sammelstelle Ihres kommunalen Entsorgungsträgers (z. B. Wertstoffhof). Nach dem Elektro- und Elektronikgerätegesetz sind Besitzer von Altgeräten gesetzlich verpflichtet, alte **Elektro- und Elektronikgeräte** einer getrennten Abfallerfassung zuzuführen. Das Symbol bedeutet, dass Sie das Gerät auf keinen Fall in den Hausmüll werfen dürfen!



Gefährdung von Gesundheit und Umwelt durch Akkus und Batterien!



Akkus und Batterien nie öffnen, beschädigen, verschlucken oder in die Umwelt gelangen lassen. Sie können giftige und umweltschädliche Schwermetalle enthalten. Sie sind gesetzlich verpflichtet, Akkus und Batterien beim batterievertreibenden Handel sowie bei zuständigen Sammelstellen, die entsprechende Behälter bereitstellen, sicher zu entsorgen. Die Entsorgung ist unentgeltlich. Die Symbole bedeuten, dass Sie Akkus und Batterien auf keinen Fall in den Hausmüll werfen dürfen und sie über Sammelstellen der Entsorgung zugeführt werden müssen.

Verpackungsmaterialien entsorgen Sie entsprechend den lokalen Vorschriften.

2 Telefon in Betrieb nehmen

Sicherheitshinweise



Achtung: Lesen Sie vor der Inbetriebnahme unbedingt die Sicherheitshinweise in Kapitel 1.

Verpackungsinhalt prüfen

Zum Lieferumfang gehören:

Inhalt	TF 520
Basisgerät	1
Netzteil	1
Hörer	1
Hörerspiralkabel	1
Notrufgeber mit Armband und Halsband (spritzwassergeschützt)	1
Telefonanschlusskabel	1
Batterien Typ AA 6 V	4
Batterie Typ A23 12 V (im Notrufgeber eingesetzt)	1
Wandmontagehalterung	1
Bedienungsanleitung	1

Wichtiger Hinweis

Ihr Gerät ist mit einem energieeffizienten Schaltnetzteil (Input 230 V_{AC}, Output 9 V_{DC}, 300 mA) ausgestattet. Die Nulllast beträgt ca. 0,1 W. Die durchschnittliche Effizienz beträgt > 68,46 %. Die Leistungsaufnahme beträgt max. 3,91 W.

Basisgerät anschließen

Schließen Sie das Telefon wie auf der Skizze abgebildet an. Verwenden Sie aus Sicherheitsgründen nur das mitgelieferte Netzteil sowie das beige-fügte Telefonanschlusskabel.

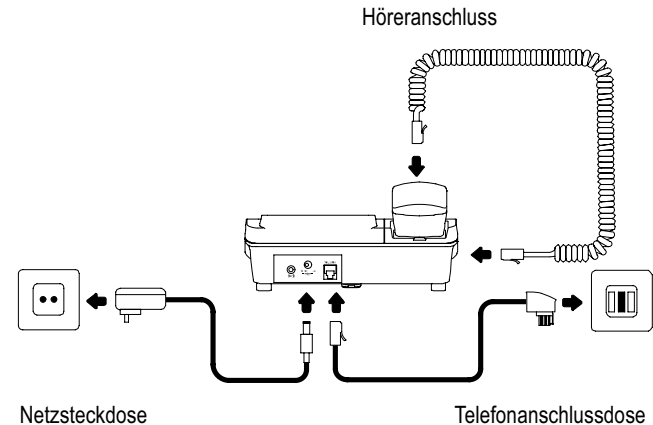

Sie können das Telefon mit oder ohne Netzteil betreiben. Wenn Sie das Telefon ohne Netzteil betreiben wollen, stellen Sie sicher, dass geladene Batterien vom richtigen Batterietyp korrekt eingesetzt sind.

Telefon in Betrieb nehmen

Batterien einlegen

 Achten Sie immer darauf, dass das Telefon nicht mit dem Telefonanschluss und/oder Netzanschluss verbunden ist, wenn Sie die Batterien einlegen oder austauschen.

Legen Sie die Batterien in das geöffnete Batteriefach ein. Verwenden Sie nur Batterien des Typs AA 6 V. Achten Sie auf die richtige Polung! Schließen Sie das Batteriefach.

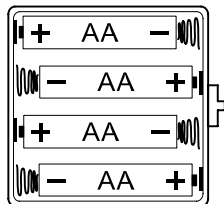

 Das Einlegen von Batterien ist nicht zwingend erforderlich. Sie können das Telefon mit oder ohne Batterien betreiben. Wenn Sie das Telefon ohne Batterien betreiben wollen, muss jedoch zwingend das Netzteil angeschlossen sein.

 **Achtung:** Wenn Sie das Telefon ohne Batterien betreiben, können Sie bei einem Stromausfall nicht mehr mit dem Gerät telefonieren oder einen Notruf absetzen!

Sind die Batterien nicht mehr voll geladen oder sind sie leer, wird im Display das Batterie-Symbol  angezeigt. Tauschen Sie die Batterien aus.

Datum und Uhrzeit einstellen

 Menü Seite 16

Diverse Einstellungen

Über das Menü können Sie verschiedene Einstellungen an Ihrem Telefon vornehmen, z. B. Wahlverfahren (MFV/IWV), Klingeltöne (KLING.TON), Tastentöne (TAST.TON), Displaykontrast (KONTRAST), die Ansage gedrückter Tasten (STIMME), das Leuchten von LEDs und vieles mehr

 Menü Seite 16.

Nebenstellenanlagen

Auf Seite 15 erhalten Sie weitere Informationen, falls Sie Ihr Telefon an eine Nebenstellenanlage anschließen möchten.

Wandmontage

Führen Sie die Führungsnasen (1) der Wandmontagehalterung (2) in die Führungsnuten (3) auf der Rückseite des Telefons ein. Schieben Sie die Wandmontagehalterung (2) 10 mm nach oben, bis sie hörbar einrastet. Bohren Sie ein Loch und lassen Sie eine Schraube ca. 5 mm aus der Wand herausstehen. Führen Sie die Aufhängung (4) der Wandmontagehalterung (2) über die Schraube und schieben Sie das Telefon nach unten.



Achtung: Unter dem zu bohrenden Loch dürfen sich keine Kabel befinden.

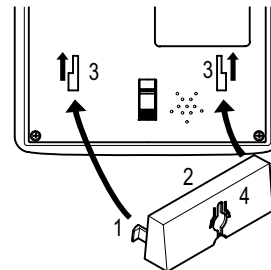

Drehen Sie den Einhängehaken (5) in der Hörerablage um, damit Sie den Hörer einhängen können.

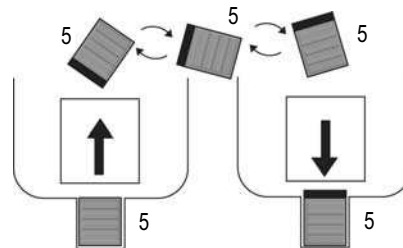

3 Bedienelemente

Telefon

- | | |
|---|---|
| 1 Schieberegler für Hörerlautstärke | 13 Menü-Taste  |
| 2 Lautsprecher (für Freisprechfunktion) | 14 R-Taste  |
| 3 Hörer | 15 Anruf- und Wahlwiederholung-Taste  |
| 4 Telefonbuch-Taste  | 16 Verstärker-LED |
| 5 Lösch-/Zurück-Taste  | 17 Verstärker-Taste (+40 dB)  |
| 6 Gespräch-/OK-Taste  | 18 Freisprech-Taste  |
| 7 Abwärts-Taste / Freisprechlautstärke verringern  | 19 Freisprech-LED |
| 8 Aufwärts-Taste / Freisprechlautstärke erhöhen  | 20 Mikrofon |
| 9 Display | 21 Numerische Tasten (inklusive Stern- und Raute-Taste)  |
| 10 Anruf-/Notruf-LED | 22 Service-Tasten  |
| 11 große rote Notruf-Tasten (3 Stück)  | 23 Schieberegler für Klangregelung |
| 12 Direktwahl-Tasten (5 Stück)  | |

Notrufgeber

- 24 Notruf-Taste 
- 25 Batteriekapazität-LED

Die Tasten werden in dieser Bedienungsanleitung mit einer einheitlichen Kontur abgebildet. Abweichungen von Tastensymbolen Ihres Telefons gegenüber den hier abgebildeten Tastensymbolen sind möglich.

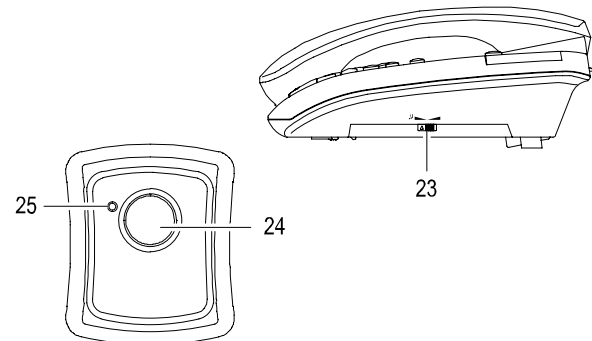
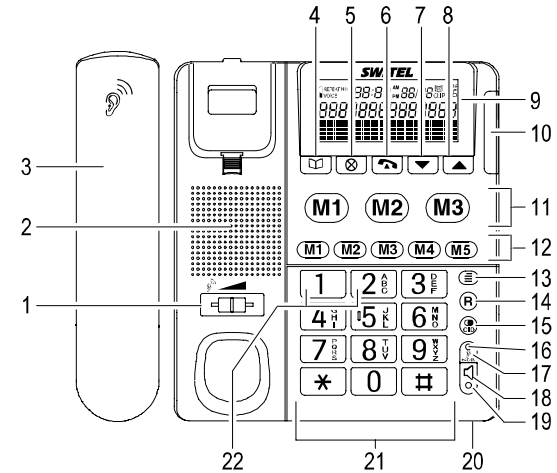

Wie bediene ich mein Telefon?

4 Wie bediene ich mein Telefon?

Darstellungen und Schreibweisen

	Ziffern oder Buchstaben eingeben
	Abgebildete Taste kurz drücken
2 x	Abgebildete Taste 2 x kurz drücken
2 Sek.	Abgebildete Taste 2 Sek. drücken
halten	Abgebildete Taste halten
loslassen	Abgebildete Taste loslassen
	Telefon klingelt
	Hörer abnehmen
	Hörer auflegen
	Text aufsprechen
	Blinkender Text im Display
SPRACHE oder	Text oder Symbole im Display

Symbole im Display

Das Display wird bei Drücken einer Taste und für eine kurze Zeit danach beleuchtet.

Symbol	Beschreibung
	Das Batterie-Symbol wird im Display angezeigt, wenn im Basisgerät keine Batterien eingelegt sind und wenn die eingelegten Batterien nicht mehr voll geladen bzw. leer sind. Legen Sie voll geladenen Batterien ein ☞ Seite 6 .
	Das Symbol mit der durchgestrichenen Glocke wird im Display angezeigt, wenn die Klingellautstärke ausgeschaltet ist (Stufe 0, stumm) ☞ Seite 9 .
	Das Freisprech-Symbol wird im Display angezeigt, wenn am Gerät die Freisprechfunktion aktiv ist ☞ Seite 11
	Das Telefon-Symbol wird im Display angezeigt, wenn sich in der Anruf- und Wahlwiederholungsliste neue Einträge befinden ☞ Seite 19

Symbol	Beschreibung
	Das Notruf-Symbol wird im Display angezeigt, sobald ein automatischer Notruf gestartet und noch nicht beendet wurde ☞ Seite 12 .
CID	Das CID-Symbol wird im Display angezeigt, wenn Rufnummern der Anruf- und Wahlwiederholungsliste angesehen werden, von denen zuvor angerufen wurde ☞ Seite 19
	Das Wahlwiederholung-Symbol wird im Display angezeigt, wenn Rufnummern der Anruf- und Wahlwiederholungsliste angesehen werden, die zuvor gewählt wurden ☞ Seite 19
	Das Verstärker-Symbol wird im Display angezeigt, wenn über das Menü die Verstärkung der Hörerlautstärke auf +40 dB dauerhaft eingeschaltet ist ☞ Seite 9

Navigation im Menü

Alle Funktionen sind über unterschiedliche Menüs zu erreichen. Den Weg zur gewünschten Funktion entnehmen Sie der Menüstruktur [☞ Seite 16](#).



	Hauptmenü öffnen
	Gewünschtes Untermenü auswählen
	Untermenü öffnen
	Gewünschte Einstellung auswählen
	Über Tastenfeld Ziffern oder Buchstaben eingeben
	Eingaben bestätigen
	Programmier- und Speichervorgänge abbrechen und in den Stand-by-Modus zurückkehren

Jeder Vorgang wird automatisch abgebrochen, wenn innerhalb von 15 Sekunden keine Eingabe erfolgt.

5 Telefonieren

Anruf annehmen



Geht ein Anruf ein, blinkt die Anruf-/Notruf-LED.



 Das Blinken der Anruf-/Notruf-LED kann verstärkt werden
 Menü Seite 16 (RINGBLITZ).

,  oder  Anruf annehmen

oder

 Anruf annehmen (Freisprechfunktion)

 Wenn an Ihrer Telefonleitung die Rufnummernanzeige (CLIP) zur Verfügung steht ( Seite 15) und Sie über das Menü STIMME:EIN ausgewählt haben, wird Ihnen vor dem Klingelton die Rufnummer des Anrufers angesagt.

 Wurde die Rufnummer eines Anrufers im Telefonbuch ( Seite 17) abgespeichert und dafür ein Name aufgesprochen, wird zwischen den ersten Klingeltönen der aufgezeichnete Name wiedergegeben.

Anzeige der Gesprächsdauer

Während eines Gesprächs wird die Gesprächsdauer in Minuten und Sekunden angezeigt.

Gespräch beenden

 oder  Gespräch beenden

oder (wenn Freisprechfunktion aktiv)

 Gespräch beenden

Anrufen

 Rufnummer eingeben
 (max. 22 Stellen)

 Bei Falscheingabe letzte Ziffer löschen

 Rufnummer wählen

oder

 oder  Rufnummer wählen
 (Freisprechfunktion)

 Sie können auch zuerst den Hörer abnehmen und erhalten damit das Freizeichen. Die eingegebenen Ziffern Ihrer gewünschten Rufnummer werden sofort gewählt. Eine Korrektur einzelner Ziffern der Rufnummer ist bei dieser Form des Gesprächsaufbaus nicht möglich.

Klingellautstärke einstellen

Die Klingellautstärke kann über das Menü in 5 Stufen eingestellt werden

 Seite 16:

- Stufe 0: Klingellautstärke aus (stumm)
- Stufe 1: Klingellautstärke leise
- Stufe 4: Klingellautstärke laut

Hörerlautstärke einstellen

Passen Sie die Hörerlautstärke mit dem Schieberegler an, der sich unterhalb des aufgelegten Hörers befindet:

- Schieberegler nach links: Hörerlautstärke ist leiser.
- Schieberegler nach rechts: Hörerlautstärke ist lauter.

Hörerlautstärke auf +40 dB verstärken

Die Hörerlautstärke kann durch Drücken der Verstärker-Taste auf +40 dB verstärkt werden.

 Hörerlautstärke verstärken

 Verstärkung ausschalten

Sie können das Telefon über das Menü so einstellen, dass die Verstärkung auf +40 dB direkt aktiv ist, ohne dass Sie zuvor die Verstärker-Taste drücken müssen. Wählen Sie im Menü BOOST BLK:EIN
 Menü Seite 16.

Klangregelung für Hörer





 Die Klangregelung funktioniert nur, wenn die Verstärkung der Hörerlautstärke auf +40 dB aktiviert ist (Verstärker-LED leuchtet).

Sie können den Klang im Hörer mit einem Schieberegler an der rechten Gehäusesseite anpassen.

Telefonieren

Wahlwiederholung und entgangene Anrufe zurückrufen

Ihr Telefon speichert die 15 letzten Rufnummern in einer Anruf- und Wahlwiederholungsliste  Seite 19.

	Liste öffnen
 oder 	gewünschte Rufnummer auswählen
	Rufnummer wählen

- Bei gewählten Rufnummern wird im Display das Wahlwiederholung-Symbol  angezeigt.
- Bei eingegangenen Rufnummern wird im Display das CID-Symbol CID (engl. **C**aller **I**dentification) angezeigt.

Rufnummern aus dem Telefonbuch wählen







Sie müssen Rufnummern im Telefonbuch gespeichert haben  Seite 17.

	Telefonbuch öffnen
 oder 	Eintrag auswählen
 , 	Verbindung herstellen

Direktwahl

Ihr Telefon verfügt über 5 Direktwahl-Tasten (M1 bis M5) (M = engl. Memory), über die Sie häufig verwendete Rufnummern einfach anwählen können.







Direktwahl-Tasten programmieren

	Rufnummer eingeben (max. 22 Stellen)
halten  ,  ,  ,	
 oder  	Rufnummer auf Direktwahl-Taste programmieren



Programmierte Rufnummern können nicht gelöscht werden, sie können nur mit neuen Rufnummern überschrieben werden.

Anrufen über Direktwahl-Tasten

 ,  ,  ,	
 oder 	Gewünschte Direktwahl-Taste drücken
 oder 	Verbindung herstellen

Notruf-Tasten

Ihr Telefon verfügt über 3 große rote Notruf-Tasten, über die Sie wichtige Rufnummern einfach anwählen können.

Notruf-Tasten programmieren



Beachten Sie, dass die Rufnummern, die auf die 3 Notruf-Tasten programmiert werden, bei einem automatischen Notruf nacheinander angerufen werden, beginnend bei M1  Seite 12.



Rufnummer eingeben
(max. 22 Stellen)

halten , ,



oder  

Rufnummer auf Notruf-Taste programmieren



Programmierte Rufnummern können nicht gelöscht werden, sie können nur mit neuen Rufnummern überschrieben werden. Um die Cursorposition in einem bestehenden Eintrag zu verändern, drücken Sie die Aufwärts- und Abwärts-Taste. Zum Löschen von Zeichen drücken Sie die Lösch-/Zurück-Taste.

Anrufen über Notruf-Tasten

,  oder 

Gewünschte Notruf-Taste drücken











 oder 

Verbindung herstellen

Service-Tasten



Sie können auf die Tasten **1** und **2^{ABC}** spezielle Service-Rufnummern programmieren und diese Rufnummern über die Tasten einfach und schnell anrufen.

Service-Tasten programmieren

	Hauptmenü öffnen
 oder 	Funktion auswählen
DIENSTE, 	und bestätigen
KEY 1,2,  oder  ,	Taste 1 oder 2 auswählen (die Ziffer der aktiven Taste blinkt) und bestätigen
	
 	Rufnummer eingeben (max. 22 Stellen) und bestätigen
  , GESPEICH.	Namen eingeben (max. 10 Stellen) und bestätigen

 Programmierte Rufnummern können nicht gelöscht werden, sie können nur mit neuen Rufnummern überschrieben werden. Um die Cursorposition in einem bestehenden Eintrag zu verändern, drücken Sie die Aufwärts- und Abwärts-Taste. Zum Löschen von Zeichen drücken Sie die Lösch-/Zurück-Taste.

Anrufen über Service-Tasten

halten 1 oder 2^{ABC}	Gewünschte Service-Taste halten, bis die Rufnummer angezeigt wird
 oder 	Verbindung herstellen

Freisprechfunktion

Nutzen Sie die Freisprechfunktion, um den Gesprächspartner über den Lautsprecher zu hören und mit ihm ohne Hörer am Ohr zu sprechen.

 Freisprechen während des Gesprächs einschalten

Bei aktivem Freisprechen leuchtet die Freisprech-LED rot.

Sprechen Sie in Richtung Mikrofon. Das Mikrofon befindet sich vorne rechts am Basisgerät.

 Freisprechen während des Gesprächs ausschalten

 Es kann beliebig zwischen Freisprechen und dem Telefonieren mit Hörer gewechselt werden. Wichtig: Der Hörer muss dabei vom Basisgerät abgenommen sein!

 Hintergrundgeräusche, z. B. laute Musik, können das Freisprechen beeinträchtigen.

Einstellen der Freisprechlautstärke

Sie können die Freisprechlautstärke über die Aufwärts- und Abwärts-Tasten in 8 Stufen von leise (Stufe 1) bis laut (Stufe 8) anpassen.

 Freisprechlautstärke verringern

 Freisprechlautstärke erhöhen

Automatischer Notruf

6 Automatischer Notruf



Ein automatischer Notruf kann nur abgesetzt werden, wenn

- im Menü NOTRUFFUNK:EIN aktiviert ist ☞ Menü Seite 16,
- das Telefon über das Netzteil betrieben wird
- bzw. wenn im Telefon 4 geladene Batterien eingesetzt sind und im Notrufgeber 1 geladene Batterie eingesetzt ist.

Über den automatischen Notruf können Sie Hausnotrufdienste oder Personen zu Hilfe rufen.



Es gibt viele geeignete Hausnotrufdienste, wie z. B. "Rotes Kreuz", "Malteser Hilfswerk" und "Die Johanniter". In manchen Ländern sind Hausnotrufdienste kostenpflichtig. Sie können dieses Notruftelefon auch als private Notrufeinrichtung in der Familie nutzen.

Funktionsweise des automatischen Notrufs

Ihr Telefon verhält sich nach dem Start eines automatischen Notrufs folgendermaßen:

- Für 15 Sekunden ertönt am Basisgerät ein lautes Notruf-Signal. Gleichzeitig blinkt die Anruf-/Notruf-LED.



Wenn Sie im Menü STUMM NOTR:EIN aktiviert haben, wird das Notruf-Signal nicht abgespielt. Es blinkt dann nur die Anruf-/Notruf-LED.

- Die Freisprechfunktion des Geräts schaltet sich ein.
- Die gespeicherten Rufnummern der 3 Notruf-Tasten werden nacheinander angerufen:
- Zuerst wird die Notruf-Nummer angerufen, die auf der großen roten M1-Taste (M1) gespeichert ist.
- Es klingelt maximal 60 Sekunden. Hat während dieser Zeit niemand abgenommen, wird der Anruf beendet.
- Für 15 Sekunden ertönt am Basisgerät erneut das Notruf-Signal.
- Es wird für 60 Sekunden versucht die Notruf-Nummer anzurufen, die auf der großen roten M2-Taste (M2) gespeichert ist.

- Ist dort auch niemand zu erreichen, wird nach gleichem Schema versucht nach 15 Sekunden Notruf-Signal die Notruf-Nummer anzurufen, die auf der großen roten M3-Taste (M3) gespeichert ist.



Haben Sie keine Rufnummer auf einer der 3 großen roten Tasten (M1), (M2) oder (M3) gespeichert, wird keine Rufnummer gewählt, sondern nur das Notruf-Signal wiedergegeben.

- Sobald der Anruf von einer Person entgegengenommen wird, hört diese die Notrufansage in einer Endlosschleife.



Werkseitig ist bereits folgende Notrufansage aufgesprochen: "Dies ist ein Notruf. Zur Annahme, bitte Null drücken." Sie können aber auch eine eigene Notrufansage aufnehmen ☞ Seite 13.

- Durch Drücken der Taste [0] am Telefon des Notruf Empfängenden beendet dieser die Notrufansage und wird automatisch mit dem Notruf Sendendem verbunden. Der Notruf Sendende spricht dabei über die Freisprechfunktion.



Wird der Notruf von Niemandem angenommen, beginnt das Telefon einen neuen Durchgang und ruft nacheinander wieder in gleicher Weise die Notruf-Nummern an, die auf den großen roten Tasten (M1), (M2) und (M3) gespeichert sind. Insgesamt führt das Telefon 4 Durchgänge durch, was ca. 15 Minuten dauert. Nimmt niemand den Notruf entgegen, wird der automatische Notruf danach automatisch beendet.

Rufnummern auf Notruf-Tasten programmieren

☞ Seite 10

Automatischen Notruf starten



Auf die Notruf-Tasten müssen fehlerfrei funktionierende Rufnummern programmiert worden sein, um Hilfe von außerhalb rufen zu können.

Automatischer Notruf über den Notrufgeber



Achten Sie darauf, dass sich immer eine volle Batterie im Notrufgeber befindet, der Notrufgeber am Telefon angemeldet ist und sich in Reichweite des Telefons befindet!

Halten Sie am Notrufgeber die Notruf-Taste für mindestens 1 Sekunde gedrückt.



Für die Dauer des Gedrückhaltens der Notruf-Taste leuchtet die Batteriekapazität-LED dauerhaft.

Automatischer Notruf über das Telefon

halten **(M1)**, **(M2)** oder **(M3)** automatischen Notruf starten

Automatischen Notruf beenden durch den Notruf Sendenden

3 Sek. automatischen Notruf beenden

oder

automatischen Notruf beenden

oder

automatischen Notruf beenden

Automatischen Notruf beenden durch den Notruf Empfangenden

automatischen Anruf annehmen

0 automatischen Notruf annehmen

mit dem Notruf Sendenden sprechen

1 **2** automatischen Notruf beenden

Automatisches Notrufende

Der automatische Notruf endet automatisch, wenn bei allen 3 Rufnummern, die auf den Notruf-Tasten hinterlegt sind, niemand erreicht werden konnte.

Notrufansage

Es befindet sich bereits eine voreingestellte Notrufansage auf Ihrem Telefon: "Dies ist ein Notruf. Zur Annahme, bitte Null drücken.". Diese Notrufansage können Sie durch eine eigene Notrufansage ersetzen.

Die Notrufansage wird so lange wiedergegeben, bis der Notruf von einer Person an deren Telefon mit der Taste [0] angenommen wird. Beenden Sie deshalb Ihre eigene Notrufansage grundsätzlich mit dem Satz: "**Drücken Sie Taste 0, um diesen Notruf entgegenzunehmen!**".



Achten Sie in Ihrer Ansage darauf, dass der Angerufene erkennt, von wem der Notruf kommt. Weisen Sie in Ihrer Ansage deutlich darauf hin, dass es sich um einen Notruf handelt und Sie Hilfe benötigen.

Notrufansage anhören

Hauptmenü öffnen

oder Untermenü auswählen

NOTBERICHT

Notrufansage abspielen

Notrufansage aufnehmen

Die Notrufansage darf maximal 30 Sekunden dauern.

Hauptmenü öffnen

oder Untermenü auswählen

NOTBERICHT

halten Aufnahme starten

loslassen Aufnahme beenden

Notrufansage löschen

Hauptmenü öffnen

oder Untermenü auswählen

NOTBERICHT

halten < 3 Sek. Löschvorgang durchführen

Notrufgeber am Telefon an- und abmelden

Notrufgeber am Telefon anmelden

Es können maximal 5 Notrufgeber am Telefon angemeldet werden.

Hauptmenü öffnen

oder ANHANGER Untermenü auswählen und bestätigen

oder REG ... Untermenü auswählen und bestätigen

1 Sek. OK Notrufgeber anmelden

War der Anmeldevorgang nicht erfolgreich, zeigt das Display kurzzeitig die Meldung FEHLER.

Automatischer Notruf

Notrufgeber am Telefon abmelden



Es können nur alle Notrufgeber zusammen abgemeldet werden!
Anschließend müssen Sie die Notrufgeber, die weiter benötigt werden, wieder am Telefon anmelden!



Hauptmenü öffnen

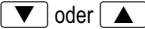

Untermenü auswählen



und bestätigen

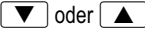



Untermenü auswählen



und bestätigen

Batterie Notrufgeber

Batterie prüfen

1. Halten Sie die Notruf-Taste  am Notrufgeber kurz gedrückt. Die Batteriekapazität-LED leuchtet für die Dauer des Drückens.
2. Leuchtet die Batteriekapazität-LED beim Halten der Notruf-Taste  nicht mehr, tauschen Sie die Batterie aus.

Batterie austauschen

1. Entfernen Sie die 4 Schrauben auf der Rückseite des Notrufgebers mit einem kleinen Kreuzschlitzschraubendreher.
2. Öffnen Sie die Abdeckung des Batteriefachs z. B. mit Hilfe eines schmalen Schraubendrehers.
3. Tauschen Sie die Batterie aus. Verwenden Sie nur eine Batterie vom Typ A23 12V. Achten Sie auf die richtige Polung!
4. Schließen Sie die Abdeckung des Batteriefachs in umgekehrter Reihenfolge.

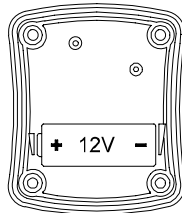

7 Nebenstellenanlagen / Zusatzdienste

R-Taste an Nebenstellenanlagen

Ist Ihr Telefon an einer Nebenstellenanlage angeschlossen, können Sie über die **R-Taste** Funktionen, wie z. B. Anrufe weiterleiten und automatischen Rückruf, nutzen. Lesen Sie bitte in der Bedienungsanleitung Ihrer Nebenstellenanlage, welche Flash-Zeit Sie zur Nutzung dieser Funktionen einstellen müssen. Ob Ihr Telefon an Ihrer Nebenstellenanlage einwandfrei funktioniert, erfahren Sie bei dem Händler, bei dem die Anlage gekauft wurde.

Flash-Zeit einstellen

☞ Menü Seite 16

Wahlpause

Bei Nebenstellenanlagen ist es erforderlich, eine Amtskennzahl vorzuwählen, um ein Freizeichen zu bekommen. Bei wenigen, älteren Nebenstellenanlagen dauert es einige Zeit, bis das Freizeichen zu hören ist. Für diese Nebenstellenanlagen kann nach der Amtskennzahl eine Wahlpause eingefügt werden, um direkt weiterwählen zu können, ohne das Freizeichen abzuwarten.



Wahlpause einfügen
"P" wird im Display angezeigt

Nach der Amtskennzahl wartet Ihr Telefon für ca. 3 Sekunden mit dem Wählen der eigentlichen Rufnummer.



Die Pause kann auch bei der Eingabe von Rufnummern in das Telefonbuch eingegeben werden.

R-Taste und Zusatzdienste

Ihr Telefon unterstützt Zusatzdienste Ihres Netzbetreibers, wie z. B. Makeln, Anklopfen und Konferenz. Über die **R-Taste** können Sie diese Zusatzdienste nutzen. Bitte fragen Sie Ihren Netzbetreiber, welche Flash-Zeit Sie zur Nutzung von Zusatzdiensten einstellen müssen. Zur Freischaltung von Zusatzdiensten wenden Sie sich bitte an Ihren Netzbetreiber. Einstellen der Flash-Zeit ☞ Seite 16.

Rufnummernanzeige (CLIP¹)

Wenn diese Funktion an Ihrer Telefonleitung zur Verfügung steht, wird Ihnen bereits die Rufnummer des Anrufers angezeigt, wenn das Telefon klingelt. Ist die Rufnummer im Telefonbuch gespeichert, wird im Display auch der gespeicherte Name angezeigt.



Wurde für einen Telefonbucheintrag ein Name aufgesprochen, wird zwischen den ersten Klingeltönen der aufgezeichnete Name wiedergegeben. So müssen Sie nicht erst zum Telefon gehen, um zu sehen, wer Sie anruft.

Hat der Anrufer das Übertragen seiner Rufnummer unterdrückt, wird eine entsprechende Meldung angezeigt. Die Rufnummer kann nicht angezeigt und somit auch nicht in der Anruf- und Wahlwiederholungsliste gespeichert werden.





Die Rufnummernanzeige ist ein optionaler Service Ihres Netzbetreibers. Fragen Sie Ihren Netzbetreiber nach weiteren Informationen.







¹ CLIP: Calling Line Identification Presentation

Menüstruktur

8 Menüstruktur

Hauptmenü

In das Hauptmenü gelangen Sie durch Drücken der Taste .
Bestätigen Sie jede Eingabe mit Taste .

ZEIT/DATUM	 /  zum Ändern der Ziffern
DIENSTE	KEY 1,2
	mit  /  Ziffer 1 oder 2 auswählen ¹  Nummer eingeben  Namen eingeben
MFV/IWV ²	MFV / IWV
NEU ANR L ³	EIN / AUS
R-TASTZEIT ⁴	100 / 300 / 600
TAST.TON	EIN / AUS
KONTRAST	1 / 2 / 3 / 4
RINGBLITZ ⁵	EIN / AUS
NOTBERICHT	Notbericht wird angesagt
STUMM NOTR	EIN / AUS
NOTRUFFUNK	EIN / AUS
BOOST BLK	EIN / AUS



¹ Die ausgewählte Ziffer blinkt.

² Mehrfrequenzwahlverfahren (MFV) (Tonwahlverfahren) und Impulswahlverfahren (IWV)

³ Legt fest, ob bei neuen Anrufen in der Anruf- und Wahlwiederholungsliste die Anruf-/Notruf-LED leuchten soll.

⁴ in ms

⁵ Wenn das Telefon klingelt, blinkt/blitzt die Anruf-/Notruf-LED stärker als üblich.

KLING.LAUT	0 / 1 / 2 / 3 / 4
KLING.TON	1 / 2 / 3
STIMME ⁶	EIN / AUS
ANHANGER	REG
	LÖSCHEN?
NAME AUFN	
NR SPEICH.	 Nummer eingeben  Namen eingeben
SPRACHE	DEUTSCH
	ENGLISH
	SVENSKA
	NEDERLANDS
	FRANCAIS
	ITALIANO

⁶ Das Drücken einiger Tasten wird zusätzlich von einer Stimme begleitet. Diese Stimme können Sie ein- und ausschalten.

9 Telefonbuch

Im Telefonbuch können Sie 99 Rufnummern mit den dazugehörigen Namen speichern. Rufnummern dürfen maximal 22 Ziffern bzw. Stellen umfassen, Namen maximal 10 Zeichen bzw. Stellen.





- Geben Sie bei allen Rufnummern immer die Vorwahl mit ein, damit auch eingehende Ortsgespräche einem Telefonbucheintrag zugeordnet werden können.
- Ist die Speicherkapazität erschöpft, zeigt das Display beim nächsten Speichern die Meldung **VOLL**. Um wieder Platz zu schaffen, müssen Sie zuerst einen anderen Eintrag löschen.
- Die Telefonbucheinträge sind alphabetisch geordnet. Um direkt zum gewünschten Telefonbucheintrag zu gelangen, drücken Sie den entsprechenden Anfangsbuchstaben.
- Wird bei geöffnetem Telefonbuch 30 Sekunden keine Taste gedrückt, kehrt das Telefon in den Stand-by-Modus zurück.

Namen eingeben

Namen dürfen maximal 10 Zeichen bzw. Stellen umfassen.













Die Ziffern-Tasten sind mit Buchstaben beschriftet. Durch mehrmaliges Drücken der entsprechenden Taste können Buchstaben, Ziffern und Sonderzeichen eingegeben werden.

 Um den gleichen Buchstaben zweimal einzugeben, drücken Sie den entsprechenden Buchstaben. Warten Sie, bis der Cursor eine Stelle weitersprungen ist. Geben Sie den Buchstaben erneut ein.

	Leerzeichen eingeben
	Zeichen löschen
 oder 	Cursorposition (blinkendes Zeichen) wechseln

 In bestehendem Text können neue Zeichen immer vor der Cursorposition eingegeben werden.

Telefonbucheinträge erstellen











	Hauptmenü öffnen
 oder 	Funktion auswählen
NR SPEICH. , 	und bestätigen
 	Rufnummer eingeben (max. 22 Stellen) und bestätigen
  , GESPEICH. , 	Namen eingeben (max. 10 Stellen)
NAME AUFN	und bestätigen
halten   loslassen 	Namen aufnehmen

 Eine Aufnahme darf maximal 4 Sekunden dauern. Danach wird die Aufnahme automatisch abgebrochen.

Nach der Aufnahme wird der aufgesprochene Name wiedergegeben.

 Die Aufnahme eines Namens ist optional und kann gegebenenfalls auch separat erfolgen. Vorteil der Aufnahme eines Namens: Ruft diese Nummer an, wird zwischen den ersten Klingeltönen 2-mal der aufgesprochene Name wiedergegeben. So müssen Sie nicht erst zum Telefon gehen, um zu sehen, wer Sie anruft.

Telefonbucheinträge ändern

	Telefonbuch öffnen
 oder 	Telefonbucheintrag auswählen
2 Sek. 	Änderungsvorgang einleiten
 	Rufnummer ändern und bestätigen
 	Namen ändern und bestätigen
halten   loslassen 	Namen aufnehmen

Telefonbuch

Telefonbucheinträge löschen

Einen Eintrag löschen



Telefonbuch öffnen

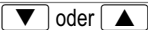

Telefonbucheintrag auswählen

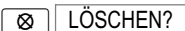

Löschvorgang aktivieren

2 Sek.

Löschvorgang bestätigen

Alle Einträge löschen



Telefonbuch öffnen

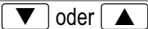

Telefonbucheintrag auswählen

2 Sek. ALL LÖSCH?

Löschvorgang aktivieren

2 Sek.

Löschvorgang bestätigen

Sprachausgabe für Telefonbucheinträge

Wenn Sie Rufnummern in Ihrem Telefonbuch gespeichert haben, können Sie zu jedem Telefonbucheintrag einen Namen aufnehmen. Wenn Sie dann einen Eintrag im Telefonbuch auswählen, wird Ihre Aufnahme wiedergegeben und Sie hören, welchen Eintrag Sie ausgewählt haben.



Namen können direkt im Zuge des Erstellens eines Telefonbucheintrags aufgenommen werden, aber auch nachträglich für bestehende Telefonbucheinträge.

Namen aufnehmen



Hauptmenü öffnen

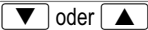

Funktion auswählen



und bestätigen

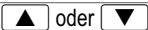

Telefonbucheintrag auswählen

halten

Aufnahme starten

loslassen

Aufnahme beenden



Wenn Sie die Taste nicht loslassen, wird die Aufnahme nach 4 Sekunden automatisch beendet.

Aufnahme löschen



Telefonbuch öffnen

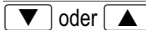

Telefonbucheintrag auswählen

2 Sek.

Änderungsvorgang einleiten



ggf. Rufnummer ändern und bestätigen



ggf. Namen ändern und bestätigen

NAME AUFN halten

(«langer Signalton»)

loslassen

Sprachausgabe für Telefonbucheintrag löschen

10 Anruf- und Wahlwiederholungsliste

Insgesamt werden die 15 letzten Rufnummern von eingehenden Anrufen und die 15 zuletzt gewählten Rufnummern in einer kombinierten Anruf- und Wahlwiederholungsliste (nachfolgend nur "Liste" genannt) gespeichert.

Neue Anrufe

Sind neue Anrufe in der Liste vorhanden, wird im Display das Telefon-Symbol  angezeigt.

Wenn im Menü NEU ANR L:EIN eingestellt ist, zeigt die rot blinkende Anruf-/Notruf-LED an, dass neue Anrufe in der Liste gespeichert wurden. Sobald die Einträge angesehen wurden, erlischt die Anruf-/Notruf-LED.

 Menü Seite 16

Rufnummern aus der Liste anzeigen



 Liste öffnen

 Der neueste Eintrag wird zuerst angezeigt.

oder
 Liste öffnen und neuesten Eintrag anzeigen

oder
 Liste öffnen und ältesten Eintrag anzeigen

 nächstälteren Eintrag auswählen und ansehen

oder
 oder  Eintrag auswählen und ansehen



- Bei tagesaktuellen Einträgen wird die Uhrzeit angezeigt. Bei älteren Einträgen wird das Datum angezeigt.
- Bei gewählten Rufnummern wird im Display das Wahlwiederholung-Symbol  angezeigt.
- Bei eingegangenen Rufnummern wird im Display das CID-Symbol CID (engl. **C**aller **I**dentification) angezeigt.
- Bei neu eingegangenen Rufnummern, die zuvor noch nicht

angeschaut wurden, wird im Display das Telefon-Symbol  angezeigt.



Meldungen im Display

Display	Beschreibung
KEINE NUMM	Es handelt sich um ein internationales Gespräch oder um ein Gespräch von einer Nebenstellenanlage.
ANONYM	Der Anrufer hat das Senden seiner Rufnummer unterdrückt oder es handelt sich um ein Gespräch von einer Nebenstellenanlage.

Rufnummern aus der Liste zurückrufen

 oder  Liste öffnen und Eintrag auswählen

 oder
Rufnummer wählen



oder
 oder  Rufnummer wählen (Freisprechfunktion)



Rufnummer aus der Liste im Telefonbuch speichern



Eine Rufnummer kann direkt aus der Liste im Telefonbuch gespeichert werden.

 oder  Liste öffnen und Eintrag auswählen

halten  Speichervorgang starten

  Rufnummer ggf. ändern (max. 22 Stellen) und bestätigen

  , GESPEICH. ,
NAME AUFN Namen eingeben (max. 10 Stellen) und bestätigen

halten  
loslassen  Namen aufnehmen

Anruf- und Wahlwiederholungsliste



Eine Aufnahme darf maximal 4 Sekunden dauern. Danach wird die Aufnahme automatisch abgebrochen.



Sobald die Rufnummer im Telefonbuch mit einem Namen gespeichert wurde, erscheint in der Liste zusätzlich der eingegebene Name.

Rufnummern aus der Liste löschen

Einzelne Rufnummer löschen



oder



Liste öffnen und Eintrag auswählen



LÖSCHEN?

Löschvorgang aktivieren

halten

Löschvorgang bestätigen

oder



oder



Löschvorgang abbrechen

Alle Rufnummern löschen



Kontrollieren Sie vor dem Löschen der Rufnummern, ob die Einträge angesehen wurden.



oder



Liste öffnen und Eintrag auswählen

2 Sek.

ALL LÖSCH?

Löschvorgang aktivieren

halten

Löschvorgang bestätigen

oder



oder



Löschvorgang abbrechen

11 Falls es Probleme gibt

Service-Hotline

Haben Sie Probleme mit Ihrem Telefon, kontrollieren Sie zuerst die folgenden Hinweise. Bei technischen Problemen können Sie sich an unsere Service-Hotline unter Tel. 0900 00 1675 innerhalb der Schweiz (Kosten Swisscom bei Drucklegung: CHF 2,60/min) wenden. Bei Garantieansprüchen wenden Sie sich an Ihren Fachhändler. Die Garantiezeit beträgt 2 Jahre.

Fragen und Antworten

Fragen	Antworten
Kein Telefongespräch möglich	<ul style="list-style-type: none"> - Die Telefonleitung ist nicht korrekt angeschlossen oder gestört. Verwenden Sie nur das mitgelieferte Telefonanschlusskabel. - Das Netzteil ist nicht eingesteckt oder es liegt ein totaler Stromausfall vor.
Einige Funktionen, z. B. die Verstärkung auf +40 dB oder das Freisprechen, funktionieren nicht	<ul style="list-style-type: none"> - Kontrollieren Sie, ob die Batterien richtig eingesetzt sind, der Batterietyp stimmt und die Batterien geladen sind.

Die Rufnummernanzeige (CLIP¹) funktioniert nicht

- Die Rufnummernanzeige ist ein optionaler Service Ihres Netzbetreibers. Bitte fragen Sie Ihren Netzbetreiber nach weiteren Informationen.
- Der Anrufer hat das Übertragen seiner Rufnummer unterdrückt.

Es kann kein automatischer Notruf abgesetzt werden. Stattdessen ertönt ein 2-facher Hinweiston.

- Im Menü NOTRUFFUNK ist AUS aktiviert.
- Auf den Notruf-Tasten sind keine Rufnummern programmiert.
- Das Netzteil des Telefons ist nicht richtig eingesteckt.
- Im Telefon sind keine 4 geladenen Batterien eingelegt.
- Im Notrufgeber ist keine geladene Batterie eingelegt.



¹CLIP: Calling Line Identification Presentation = Anzeige der Rufnummer eines Anrufers.

12 Pflegehinweise / Garantie

Pflegehinweise

- Reinigen Sie die Gehäuseoberflächen mit einem weichen und fusselfreien Tuch.
- Verwenden Sie keine Reinigungsmittel oder Lösungsmittel.

Garantie

SWITEL-Geräte werden nach den modernsten Produktionsverfahren hergestellt und geprüft. Ausgesuchte Materialien und hoch entwickelte Technologien sorgen für einwandfreie Funktion und lange Lebensdauer. Ein Garantiefall liegt nicht vor, wenn die Ursache einer Fehlfunktion des Geräts bei dem Telefonnetzbetreiber oder einer eventuell zwischengeschalteten Nebenstellenanlage liegt. Die Garantie gilt nicht für die in den Produkten verwendeten Batterien, Akkus oder Akkupacks. Die Garantiezeit beträgt 24 Monate, gerechnet vom Tage des Kaufs.

Innerhalb der Garantiezeit werden alle Mängel, die auf Material- oder Herstellungsfehler zurückzuführen sind, kostenlos beseitigt. Der Garantieanspruch erlischt bei Eingriffen durch den Käufer oder durch Dritte. Schäden, die durch unsachgemäße Behandlung oder Bedienung, natürliche Abnutzung, durch falsches Aufstellen oder Aufbewahren, durch unsachgemäßen Anschluss oder Installation sowie durch höhere Gewalt oder sonstige äußere Einflüsse entstehen, fallen nicht unter die Garantieleistung. Wir behalten uns vor, bei Reklamationen die defekten Teile auszubessern, zu ersetzen oder das Gerät auszutauschen. Ausgetauschte Teile oder ausgetauschte Geräte gehen in unser Eigentum über. Schadenersatzansprüche sind ausgeschlossen, soweit sie nicht auf Vorsatz oder grober Fahrlässigkeit des Herstellers beruhen.

Sollte Ihr Gerät dennoch einen Defekt innerhalb der Garantiezeit aufweisen, wenden Sie sich bitte unter Vorlage Ihrer Kaufquittung ausschließlich an das Geschäft, in dem Sie Ihr SWITEL-Gerät gekauft haben. Alle Gewährleistungsansprüche nach diesen Bestimmungen sind ausschließlich gegenüber Ihrem Fachhändler geltend zu machen. Nach Ablauf von zwei Jahren nach Kauf und Übergabe unserer Produkte können Gewährleistungsrechte nicht mehr geltend gemacht werden.

Konformitätserklärung

Dieses Gerät erfüllt die Anforderungen der EU-Richtlinie: 1999/5/EG Richtlinie über Funkanlagen und Telekommunikationsendeinrichtungen und die gegenseitige Anerkennung ihrer Konformität. Die Konformität mit der o. a. Richtlinie wird durch das CE-Zeichen auf dem Gerät bestätigt.



Für die komplette Konformitätserklärung nutzen Sie bitte den kostenlosen Download von unserer Website www.switel.com.

13 Stichwortverzeichnis

A

Abwärts-Taste, 7
 Ändern, 17
 Anruf annehmen, 9
 Anruf- und Wahlwiederholungsliste, 19
 Anruf-/Notruf-LED, 7, 19
 Anrufen, 9
 Anrufen über Direktwahl-Tasten, 10
 Anrufen über Notruf-Tasten, 10
 Anrufen über Service-Tasten, 11
 Anzeige neuer Anrufe, 19
 Aufnahme löschen, 18
 Aufstellungsort, 4
 Aufwärts-Taste, 7
 Automatischen Notruf beenden durch den Notruf Empfangenden, 13
 Automatischen Notruf beenden durch den Notruf Sendenden, 13
 Automatischen Notruf deaktivieren, 16
 Automatischen Notruf starten, 12
 Automatischen Notruf stummschalten, 16
 Automatischer Notruf, 12
 Automatischer Notruf über das Telefon, 13
 Automatischer Notruf über den Notrufgeber, 12
 Automatisches Notrufende, 13

B

Basisgerät, 5
 Batterie Notrufgeber austauschen, 14
 Batterie Notrufgeber prüfen, 14
 Batteriekapazität-LED, 7
 Batterien einlegen, 6
 Bedienelemente, 7
 Bestimmungsgemäße Verwendung, 4

D

Darstellungen, 8
 Datum, 6
 Datum und Uhrzeit einstellen, 16
 Direktwahl, 10
 Direktwahl-Tasten, 7
 Direktwahl-Tasten programmieren, 10
 Display, 7
 Displaykontrast einstellen, 16
 Displaymeldungen, 19

E

Entgangene Anrufe zurückrufen, 10
 Entsorgung, 4
 Erstellen, 17

F

Fehlerbehebung, 21
 Flash-Zeit einstellen, 15, 16
 Fragen und Antworten, 21
 Freisprech-LED, 7
 Freisprech-Taste, 7
 Freisprechen, 11
 Freisprechfunktion, 11
 Freisprechlautstärke, 11

G

Garantie, 22
 Gespräch beenden, 9
 Gespräch-/OK-Taste, 7
 Gesprächsdauer, 9

H

Hauptmenü, 16
 Hausnotrufdienste, 12
 Hörer, 7
 Hörerlautstärke einstellen, 9
 Hörerlautstärke verstärken, 9
 Hörgeräte kompatibel, 4

I

Impulswahlverfahren, 16
 Inbetriebnahme, 5
 IWW, 16

K

Klangregelung, 7, 9
 Klingellautstärke einstellen, 9, 16
 Klingelton auswählen, 16
 Klingelton einstellen, 16
 Konformitätserklärung, 22
 Kontrast einstellen, 16

L

Lautsprecher, 7
 Lösch-/Zurück-Taste, 7
 Löschen, 18

M

Mehrfrequenzwahlverfahren, 16
 Menü-Taste, 7
 Menüstruktur, 16
 MFV, 16
 Mikrofon, 7

N

Namen aufnehmen, 18
 Namen eingeben, 17
 Navigation im Menü, 8
 Nebenstellenanlagen, 15
 Netzteil, 4
 Notbericht ansagen lassen, 16
 Notruf-Signal, 12
 Notruf-Taste, 7
 Notruf-Tasten, 7, 10
 Notruf-Tasten programmieren, 10
 Notrufansage, 12, 13
 Notrufansage anhören, 13
 Notrufansage aufnehmen, 13
 Notrufansage löschen, 13
 Notrufgeber am Telefon abmelden, 14
 Notrufgeber am Telefon anmelden, 13
 Numerische Tasten, 7

P

Pflegehinweise, 22
 Probleme, 21

R

R-Taste, 7
 R-Taste an Nebenstellenanlagen, 15
 R-Taste und Zusatzdienste, 15
 Raute-Taste, 7
 Rufnummer aus der Liste im Telefonbuch speichern, 19
 Rufnummern aus dem Telefonbuch wählen, 10
 Rufnummern aus der Liste anzeigen, 19
 Rufnummern aus der Liste löschen, 20
 Rufnummern aus der Liste zurückrufen, 19
 Rufnummernanzeige, 15

Stichwortverzeichnis

S

Schieberegler für Hörerlautstärke, 7
Schieberegler für Klangregelung, 7
Schreibweisen, 8
Service-Hotline, 21
Service-Tasten, 7, 11
Service-Tasten programmieren, 11
Sicherheitshinweise, 4
Speichern, 17
Sprachausgabe für
 Telefonbucheinträge, 18
Sprache einstellen, 16
Stern-Taste, 7
Symbole im Display, 8

T

Tastentöne ein-/ausschalten, 16
Telefonbuch, 17
Telefonbuch-Taste, 7
Telefonbucheinträge, 17
Telefonieren, 9
Texteingabe, 17
Tonwahlverfahren, 16

U

Uhrzeit, 6

V

Verpackungsinhalt, 5
Verstärker-LED, 7
Verstärker-Taste (+40 dB), 7

W

Wahlpause, 15
Wahlwiederholung, 10
Wandmontage, 6
Wie bediene ich mein Telefon?, 8

Z

Zusatzdienste, 15

1	Consignes de sécurité	26
2	Mettre le téléphone en service	27
3	Éléments de manipulation	29
4	Comment utiliser mon téléphone ?	30
5	Comment téléphoner	31
6	Appel d'urgence automatique	34
7	Installations PABX / Services confort	37
8	Structure du menu	38
9	Répertoire	39
10	Liste des appels et de répétition des derniers numéros	41
11	En cas de problèmes	43
12	Remarques d'entretien / Garantie	44
13	Index	45

Consignes de sécurité

1 Consignes de sécurité

Lisez très attentivement ce mode d'emploi.

Utilisation conforme aux prescriptions

Ce téléphone est prévu pour téléphoner à l'intérieur d'un réseau téléphonique. Toute autre utilisation est considérée comme non conforme aux prescriptions. Des modifications ou transformations effectuées de façon arbitraire sont interdites. N'ouvrez en aucun cas l'appareil et n'essayez pas de le réparer vous-même.

Lieu d'installation

Évitez les nuisances causées par la fumée, la poussière, les vibrations, les produits chimiques, l'humidité, la grande chaleur ou un ensoleillement direct.

Bloc d'alimentation



Attention : N'utilisez que le bloc d'alimentation fourni avec l'appareil, d'autres pouvant endommager le téléphone. Veillez à ce qu'aucun meuble ou autre objet ne bloque l'accès au bloc d'alimentation.

Compatible avec les aides auditives

Grâce à son combiné Premium, le téléphone est parfaitement adapté aux aides auditives et compatible avec la plupart de celles disponibles sur le marché. En raison de la grande variété de modèles, nous ne pouvons cependant pas garantir une fonction parfaite avec chaque aide auditive.



Attention : ce téléphone peut rendre des volumes sonores très élevés lorsque l'amplificateur est activé et que le régulateur se trouve sur Maximum. Il est recommandé d'être prudent lorsque vous passez d'un utilisateur présentant une difficulté d'audition à un utilisateur à audition normale.

Traitement des appareils hors d'usage

Si vous ne voulez plus servir de votre appareil, veuillez l'apporter au centre de collecte de l'organisme de traitement des déchets de votre commune (par ex. centre de recyclage).

D'après la loi relative aux appareils électriques et électroniques, les propriétaires d'**appareils électriques et électroniques** hors d'usage sont tenus de les déposer dans un collecteur séparé. L'icône ci-contre signifie que vous ne devez en aucun cas jeter votre appareil dans les ordures ménagères !



Risque pour l'homme et l'environnement lié aux piles et accus !



Ne jamais ouvrir, endommager, avaler les piles et accus ou faire pénétrer leur contenu dans l'environnement. Ils peuvent contenir des métaux lourds toxiques et nuisibles pour celui-ci. Vous êtes tenus par la loi d'apporter vos piles et accus à un revendeur de piles ainsi qu'à un centre de collecte responsables de leur traitement qui mettent des conteneurs adéquats à disposition. Ce geste écoresponsable est gratuit. L'icône ci-contre signifie que vous ne devez en aucun cas jeter les piles et accus dans les ordures ménagères, mais que vous devez les apporter à un centre de collecte.

Éliminez les **fournitures d'emballage** conformément au règlement local.

2 Mettre le téléphone en service

Consignes de sécurité



Attention : Avant de mettre votre téléphone en service, lisez impérativement les consignes de sécurité mentionnées au chapitre 1.

Vérifier le contenu du coffret

Son contenu :

Contenu	TF 520
Base	1
Bloc d'alimentation	1
Combiné	1
Câble spiralé du combiné	1
Transmetteur d'appel d'urgence avec bracelet et collier (étanche aux projections d'eau)	1
Câble de raccordement téléphonique	1
Piles de type AA 6 V	4
Pile de type A23 12 V (insérée dans le transmetteur d'appel d'urgence)	1
Fixation pour montage mural	1
Guide de l'utilisateur	1

Note importante

La station de base de votre dispositif est équipée d'une alimentation à découpage à haut rendement énergétique (entrée 230 V_{AC}, sortie 9 V_{DC}, 300 mA). Sans charge, le courant entrant s'élève à env. 0,1 W. Le rendement moyen est > 68,46 %. La puissance absorbée est max. 3,91 W.

Raccorder l'appareil de base

Raccordez le téléphone comme représenté sur le croquis. Pour des raisons de sécurité, n'utilisez que le bloc secteur ainsi que le câble de raccordement téléphonique fournis avec l'appareil.

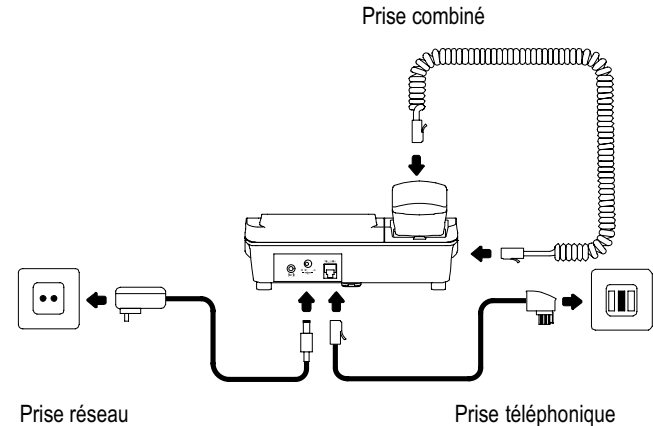

Vous pouvez vous servir de votre téléphone avec ou sans bloc d'alimentation. Si vous voulez vous servir de votre téléphone sans bloc d'alimentation, assurez-vous que des piles chargées du type correct sont insérées.

Mettre le téléphone en service

Insérer les piles



Veillez toujours observer que votre téléphone ne soit pas relié au raccordement téléphonique et/ou au réseau lorsque vous insérez ou remplacez les piles.

Insérez ces dernières dans le compartiment ouvert prévu à cet effet. N'utilisez que des piles de type AA 6 V. Veillez à ce que la polarité soit correcte ! Fermez-le.

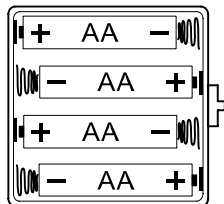

La pose de piles n'est pas impérative. Vous pouvez vous servir de votre téléphone avec ou sans piles. Si vous voulez vous servir de votre téléphone sans piles, le bloc d'alimentation doit être impérativement branché.



Attention : en cas de panne de courant, si vous vous servez du téléphone sans piles, vous ne pouvez plus téléphoner ni passer un appel d'urgence !

Si les piles ne sont plus complètement chargées ou vides, l'icône de la pile  s'affiche. Remplacez-les.

Régler la date et l'heure

 Menu page 38

Divers réglages

Le menu vous permet d'effectuer différents réglages sur votre téléphone tels que système de numérotation (FV / DC), sonneries (SON.), sons de touche (BIP), contraste écran (CONTRASTE), annonce vocale en appuyant sur les touches (GUID VOCAL), éclairage de LEDs et plus encore

 Menu page 38.

Installations PABX

La page 37 vous fournit de plus amples informations au cas où vous désiriez raccorder votre téléphone à une installation PABX.

Montage mural

Introduisez les tenons de guidage (1) de la fixation pour montage mural (2) dans les encoches (3) situées à l'arrière de votre téléphone. Poussez la fixation (2) de 10 mm vers le haut jusqu'à ce que vous entendiez son enclenchement. Percez un trou et laissez sortir une vis d'env. 5 mm du mur. Passez la suspension (4) de la fixation (2) au dessus de la vis et poussez le téléphone vers le bas.



Attention : aucun câble ne doit se trouver sous le trou à percer.

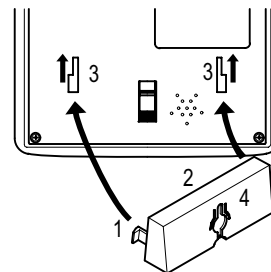



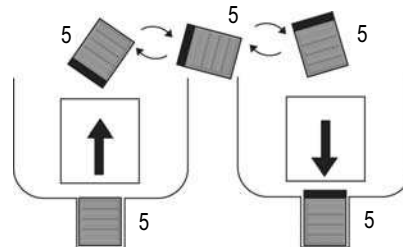





Tournez le crochet de suspension (5) dans le logement du combiné afin de pouvoir accrocher ce dernier.



3 Éléments de manipulation

Téléphone

- | | | | | | | | | | | | | | |
|---|---|--------|-------|-------|-------|-------|-------|--------|-------|--------|---|---|---|
| <p>1 Régulateur à coulisse pour le volume de l'écouteur</p> <p>2 Haut-parleur (pour mode mains-libres)</p> <p>3 Combiné</p> <p>4 Touche répertoire </p> <p>5 Touche Effacement/Retour </p> <p>6 Touche communication/OK </p> <p>7 Touche «vers le bas» / Diminuer le volume en mains libres </p> <p>8 Touche «vers le haut» / Augmenter le volume en mode mains-libres </p> <p>9 Écran</p> <p>10 LED appel/appel d'urgence</p> <p>11 Grosses touches rouges d'appel d'urgence (3 unités) M1 M2 M3</p> <p>12 Touches de sélection directe (5 unités) M1 M2 M3 M4 M5</p> | <p>13 Touche de menu </p> <p>14 Touche R R</p> <p>15 Touche d'appel et de répétition des derniers numéros </p> <p>16 LED amplificateur</p> <p>17 Touche amplificateur (+40 dB) </p> <p>18 Touche mains libres </p> <p>19 LED mains-libres</p> <p>20 Microphone</p> <p>21 Touches numériques (y compris touche étoile et dièse) <table border="1" data-bbox="552 505 771 608"> <tr><td>1</td><td>2 ABC</td><td>3 DEF</td></tr> <tr><td>4 GHI</td><td>5 JKL</td><td>6 MNO</td></tr> <tr><td>7 PQRS</td><td>8 TUV</td><td>9 WXYZ</td></tr> <tr><td>#</td><td>*</td><td>0</td></tr> </table></p> <p>22 Touches de service 1 2 ABC</p> <p>23 Régulateur à coulisse pour la régulation du son</p> | 1 | 2 ABC | 3 DEF | 4 GHI | 5 JKL | 6 MNO | 7 PQRS | 8 TUV | 9 WXYZ | # | * | 0 |
| 1 | 2 ABC | 3 DEF | | | | | | | | | | | |
| 4 GHI | 5 JKL | 6 MNO | | | | | | | | | | | |
| 7 PQRS | 8 TUV | 9 WXYZ | | | | | | | | | | | |
| # | * | 0 | | | | | | | | | | | |

Transmetteur d'appel d'urgence

- 24 Touche d'appel d'urgence 
- 25 LED capacité de la batterie

Les touches sont représentées dans ce mode d'emploi par un contour uniforme. Il peut y avoir de légères différences entre les icônes des touches de votre téléphone et celles utilisées ici.

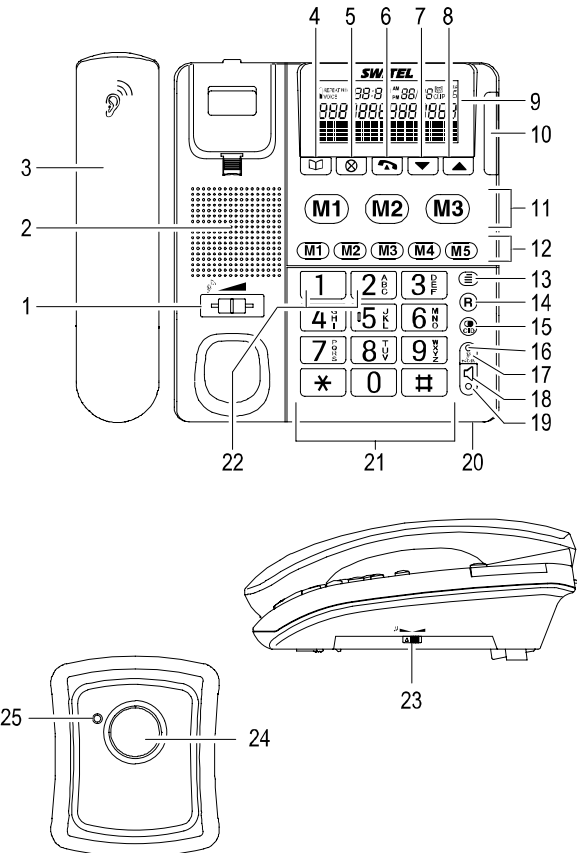

Comment utiliser mon téléphone ?

4 Comment utiliser mon téléphone ?

Représentations et notations

	Saisir des numéros ou des lettres
	Appuyer brièvement sur la touche représentée
2 x	Appuyer brièvement 2 fois sur la touche représentée
2 sec.	Appuyer 2 secondes sur la touche représentée
Maintenir	Maintenir appuyée la touche représentée
Relâcher	Relâcher la touche représentée
	Le téléphone sonne
	Décrocher
	Raccrocher
	Dire le texte
	Texte clignotant sur l'écran
LANGUE ou	Texte ou icônes d'écran

Icônes d'écran

L'écran s'allume si vous appuyez sur une touche et reste allumé encore quelque temps.

icône	Description
	L'icône de la pile s'affiche si vous n'avez pas inséré de piles dans l'appareil de base et si les piles ne sont plus complètement chargées ou si elles sont vides. Insérez des piles complètement chargées
	L'icône cloche barrée s'affiche si vous avez désactivé le volume de la sonnerie (niveau 0, muet)
	L'icône mains-libres s'affiche si cette fonction est activée
	L'icône téléphone s'affiche quand vous avez de nouveaux contacts dans la liste des appels et de répétition des derniers numéros

Icône	Description
	L'icône appel d'urgence s'affiche dès qu'un appel d'urgence a été lancé et n'a pas encore été terminé
CID	L'icône CID s'affiche si vous consultez des numéros de la liste des appels et de répétition des derniers numéros depuis lesquels vous avez appelé auparavant
	L'icône liste de répétition des derniers numéros s'affiche si vous consultez des numéros de la liste des appels et de répétition des derniers numéros depuis lesquels vous avez appelé auparavant
	L'icône amplificateur s'affiche si dans le menu, l'amplification du volume sonore de l'écouteur a été activée en permanence sur +40 dB

Navigation dans le menu

Vous pouvez accéder à toutes les fonctions dans différents menus. La structure de menu vous montre comment accéder à la fonction voulue .

	Ouvrir le menu principal
ou	Sélectionner le sous-menu désiré
	Ouvrir le sous-menu
ou	Sélectionner le réglage désiré
	Saisir des chiffres ou des lettres avec le clavier numérique
	Confirmer les entrées
	Annuler les actions de programmation et de sauvegarde et retourner en mode veille





Chaque action est automatiquement annulée si vous n'effectuez pas de saisie dans les 15 secondes.

5 Comment téléphoner

Prendre un appel



Si vous recevez un appel, la LED appel/appel d'urgence clignote.



 Le clignotement de la LED appel/appel d'urgence peut être intensifié  Menu page 38 (TEMOIN SON)

,  ou  Prendre un appel

ou

 Prendre un appel
(fonction mains-libres)

 Si votre ligne téléphonique dispose de la présentation du numéro (CLIP) ( page 37) et que vous avez sélectionné dans le menu GUID VOCAL : ON, le numéro de l'appelant sera annoncé avant la sonnerie.

 Si le numéro d'un appelant a été sauvegardé dans le répertoire ( page 39) et que vous avez annoncé un nom pour celui-ci, le nom enregistré sera reproduit entre les premières sonneries.

Affichage de la durée de la communication

Pendant la communication, sa durée s'affiche en minutes et secondes.

Terminer la communication

 ou  Terminer la communication

ou (si fonction mode-libres activée)

 Terminer la communication

Téléphoner

 Entrer le numéro d'appel
(max. 22 positions)

 Si la saisie est erronée, effacer le dernier chiffre

 Composer le numéro

ou

 ou  Composer le numéro
(fonction mains-libres)

 Vous pouvez également décrocher tout d'abord le combiné, vous obtenez alors la tonalité. Les chiffres saisis de votre numéro d'appel sont immédiatement composés. La correction individuelle des chiffres du numéro d'appel n'est pas possible quand la communication est établie de cette manière.

Régler le volume de la sonnerie

Vous pouvez régler le volume de la sonnerie sur 5 niveaux dans le menu  page 38 :

- Niveau 0 : Volume de la sonnerie coupé (MUET)
- Niveau 1 : Volume de la sonnerie faible
- Niveau 4 : Volume de la sonnerie fort

Régler le volume sonore de l'écouteur

Régler le volume de l'écouteur à l'aide du régulateur à coulisse qui se trouve sous le combiné raccroché.

- Régulateur vers la gauche : diminue le volume
- Régulateur vers la droite : augmente le volume

Amplification du volume sonore de l'écouteur sur +40 dB

Le volume sonore de l'écouteur peut être amplifié sur +40 dB en appuyant sur la touche Amplificateur.

 Amplifier le volume sonore de l'écouteur

 Désactiver l'amplification

Vous pouvez régler le téléphone via le menu de telle sorte que l'amplification sur +40 dB soit directement activée sans avoir eu besoin auparavant d'appuyer sur la touche Amplificateur. Sélectionnez dans le menu BOOST BLOQ : ON  Menu page 38.

Régulation du son de l'écouteur





 La régulation du son ne fonctionne que si l'amplification du volume sonore est activée sur +40 dB (la LED amplificateur est allumée).

Vous pouvez régler le son dans l'écouteur à l'aide d'un régulateur à coulisse placé sur le côté droit du boîtier.

Comment téléphoner

Répétition des derniers numéros et rappeler des appels en absence





Votre téléphone enregistre les 15 derniers numéros composés dans une liste des appels et de répétition des derniers numéros  page 41.

	Ouvrir la liste
 ou 	Sélectionner le numéro voulu
	Composer le numéro

- Si vous composez des numéros, l'icône de répétition des derniers numéros  s'affiche.
- Pour les numéros entrants, l'icône CID (engl. **C**aller **I**dentification) s'affiche.

Composer des numéros d'appel à partir du répertoire

Vous devez avoir enregistré des numéros dans le répertoire  page 39.





	Ouvrir le répertoire
 ou 	Sélectionner le contact
 , 	Établir la communication

Sélection directe

Votre téléphone est doté de 5 touches de sélection directe (M1 à M5) (M = engl. Memory) qui vous permettent de composer facilement des numéros que vous utilisez souvent.







Programmer les touches de sélection directe

	Entrer le numéro d'appel (max. 22 positions)
---	--

Maintenir  ,  ,  ,  ou  ENREGISTRÉ	Programmer des numéros sur la touche de sélection directe
--	---

 Vous ne pouvez pas effacer des numéros programmés, vous pouvez uniquement les écraser avec de nouveaux numéros.

Appeler à l'aide des touches de sélection directe

 ,  ,  ,  ou 	Appuyer sur la touche de sélection directe voulue
 ou 	Établir la communication

Touches d'appel d'urgence

Votre téléphone est dotée de 3 grosses touches rouges d'appel d'urgence avec lesquelles vous pouvez composer facilement des numéros importants pour vous.

Programmer les touches d'appel d'urgence



Observez que les numéros programmés sur les 3 touches d'urgence sont appelés l'un après l'autre lors d'un appel d'urgence automatique et qu'ils commencent par M1  page 34.



Entrer le numéro d'appel (max. 22 positions)

Maintenir  ,  ,

ou  ENREGISTRÉ

Programmer un numéro sur la touche d'appel d'urgence





Vous ne pouvez pas effacer des numéros programmés, vous pouvez uniquement les écraser avec de nouveaux numéros. Pour modifier la position du curseur dans un contact, appuyez sur la touche «vers le haut» et «vers le bas». Pour effacer des caractères, appuyez sur la touche Effacement/Retour.

Appeler à l'aide des touches d'appel d'urgence

 ,  ou 

Appuyer sur la touche voulue











 ou 

Établir la communication

Touches de service



Vous pouvez programmer des numéros spéciaux de service sur les touches **1** et **2^{ABC}** et appeler rapidement et facilement ces numéros avec les touches.

Programmer les touches de service

	Ouvrir le menu principal
 ou 	Sélectionner la fonction
SERVICES, 	et valider
KEY 1,2,  ou  ,	Sélectionner la touche 1 ou 2
	(le chiffre de la touche activée clignote) et valider
 	Entrer le numéro (maxi 22 positions) et valider
  , ENREGISTRÉ	Saisir le nom (max. 10 positions) et valider

 Vous ne pouvez pas effacer des numéros programmés, vous pouvez uniquement les écraser avec de nouveaux numéros. Pour modifier la position du curseur dans un contact, appuyez sur la touche «vers le haut» et «vers le bas». Pour effacer des caractères, appuyez sur la touche Effacement/Retour.

Appeler à l'aide touches de service

Maintenir 1 ou 2^{ABC}	Maintenir la touche voulue jusqu'à ce que le numéro s'affiche
 ou 	Établir la communication

Fonction mains-libres

Utilisez cette fonction pour entendre le correspondant par l'intermédiaire du haut-parleur, donc sans avoir besoin de tenir le combiné.

 Activer la fonction mains-libres pendant la communication

Si cette fonction est activée, la LED mains-libres est allumée en rouge. Parlez en direction du microphone. Celui-ci se trouve en bas à droite de l'appareil de base.

 Désactiver la fonction mains-libres pendant la communication

 Vous pouvez passer sans problème du mode mains-libres à la communication avec combiné. Important : le combiné doit être retiré de l'appareil de base !

 Des bruits de fond tels que musique forte peuvent perturber le mode mains-libres.

Régler le volume sonore en mode mains-libres

La touche «vers le haut» et «vers le bas» vous permet d'adapter le volume en mode mains-libres sur 8 niveaux de faible (niveau 1) à fort (niveau 8).

 Diminuer le volume en mode mains libres

 Augmenter le volume en mode mains libres

Appel d'urgence automatique

6 Appel d'urgence automatique



Vous pouvez uniquement passer un appel d'urgence automatique si :

- dans le menu URGENCE : ON est activé ☞ Menu page 38,
- si le téléphone marche avec le bloc d'alimentation ou
- si 4 piles chargées sont insérées dans le téléphone et 1 pile est insérée dans le transmetteur d'appel d'urgence.

Vous pouvez appeler les services d'alarme ou demander de l'aide à des personnes avec l'appel automatique d'urgence.



Il existe de nombreux services d'alarme, comme par ex. «la Croix Rouge», «les Secours hospitalier de l'ordre de Malte» et «l'Ordre Hiérosolymitain des Hospitaliers de Saint Jean». Les services d'alarme sont payants dans certains cantons.

Vous pouvez également utiliser ce téléphone d'appel d'urgence comme installation d'appel d'urgence privée au sein de votre famille.

Comment marche l'appel d'urgence automatique

Après le lancement d'un appel d'urgence automatique, votre téléphone se comporte comme suit :

- Vous entendez un signal d'appel d'urgence sur l'appareil de base pendant 15 secondes. En même temps la LED appel/appel d'urgence clignote.



Si vous avez activé dans le menu SILENC.URG : ON, vous n'entendez pas le signal d'appel d'urgence. Seule la LED appel/appel d'urgence clignote.

- La fonction mains-libres de l'appareil est activée.
- Les numéros sauvegardés des 3 touches d'appel d'urgence sont appelés l'un après l'autre :
- Le numéro enregistré sur la grosse touche rouge (M1) est appelé en premier.
- Il sonne maximum 60 secondes. Si personne n'a décroché pendant ce temps, l'appel est terminé.

- Vous entendez à nouveau le signal d'appel d'urgence sur l'appareil de base pendant 15 secondes.
- Le numéro enregistré sur la grosse touche rouge (M2) est appelé pendant 60 secondes.
- Si personne non plus ne répond, on essaie d'après le même principe d'appeler, au bout de 15 secondes de signal d'appel d'urgence, le numéro d'appel d'urgence sauvegardé sur la grosse touche rouge (M3).



Si vous n'avez pas sauvegardé de numéro sur l'une des 3 grosses touches rouges (M1), (M2) ou (M3), aucun numéro n'est composé, seul le signal d'appel d'urgence est reproduit.

- Dès qu'une personne a pris l'appel, elle entend l'annonce d'appel d'urgence en boucle.



L'annonce d'appel d'urgence suivante est déjà parlée en réglage usine : «Ceci est un appel d'urgence, pour accepter l'appel appuyez sur la touche 0.» Vous pouvez toutefois enregistrer votre propre annonce ☞ page 35.

- En appuyant sur la touche [0] du téléphone de la personne recevant l'appel d'urgence, celle-ci termine l'annonce et elle est reliée automatiquement à la personne émettant l'appel d'urgence. La personne émettant l'appel d'urgence parle avec la fonction mains-libres.



Si personne ne prend l'appel, le téléphone recommence de la même manière à rappeler l'un après l'autre les numéros d'appel d'urgence sauvegardés sur les grosses touches rouges (M1), (M2) et (M3). Le téléphone recommence 4 fois, ce qui peut durer env. 15 minutes. Si personne ne prend l'appel, l'appel d'urgence automatique est automatiquement terminé.

Programmer un numéro sur les touches d'appel d'urgence

☞ page 32

Lancer l'appel d'urgence



Il faut que des numéros aient été parfaitement programmés sur les touches d'appel d'urgence afin de pouvoir recevoir du secours de l'extérieur.

Appel d'urgence automatique via le transmetteur d'appel d'urgence



Veuillez vous assurer qu'une pile pleine se trouve toujours dans le transmetteur, que celui-ci est déclaré sur le téléphone et qu'il se trouve à proximité de ce dernier !

Appuyez pendant au moins 1 seconde sur la touche d'appel d'urgence du transmetteur.



Pendant que vous appuyez sur cette touche, la LED capacité de pile est allumée en permanence.

Appel d'urgence automatique via le téléphone

Maintenir **M1** **M2** ou **M3** Lancer l'appel automatique d'urgence

Terminer l'appel automatique d'urgence par la personne émettant l'appel

3 sec.  Terminer l'appel d'urgence automatique

ou



Terminer l'appel d'urgence automatique

ou



Terminer l'appel d'urgence automatique

Terminer l'appel automatique d'urgence par la personne recevant l'appel



Prendre l'appel automatique

0

Prendre l'appel d'urgence automatique



Parler avec la personne émettant l'appel d'urgence

1

2

Terminer l'appel d'urgence automatique

Fin de l'appel d'urgence automatique

L'appel d'urgence automatique se termine automatiquement si personne n'a pu être atteint avec les tous les 3 numéros sauvegardés sur les touches d'appel d'urgence.

Annonce d'appel d'urgence

Une annonce préréglée se trouve déjà sur votre téléphone : «Ceci est un appel d'urgence, pour accepter l'appel appuyez sur la touche 0.» Vous pouvez remplacer cette annonce par votre propre annonce.

Cette annonce est reproduite jusqu'à ce qu'une personne prenne l'appel sur son téléphone avec la touche [0]. C'est pourquoi vous devez toujours terminer votre propre annonce par la phrase : **«Appuyez sur la touche 0 pour prendre cet appel d'urgence !»**.



Veuillez dans votre annonce à ce que la personne appelée reconnaisse de qui provient l'appel d'urgence. Attirez distinctement l'attention sur le fait qu'il s'agit d'un appel d'urgence et que vous avez besoin d'aide.

Écouter l'annonce d'appel d'urgence



Ouvrir le menu principal

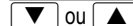

Sélectionner le sous-menu

MESSAG.URG



Écouter l'annonce d'appel d'urgence

Enregistrer l'annonce d'appel d'urgence



L'annonce d'appel d'urgence ne doit pas dépasser 30 secondes.



Ouvrir le menu principal

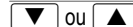

Sélectionner le sous-menu

MESSAG.URG

Maintenir  



Lancer l'enregistrement

Relâcher 

Terminer l'enregistrement

Appel d'urgence automatique

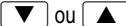





Effacer l'annonce d'appel d'urgence

	Ouvrir le menu principal
 ou 	Sélectionner le sous-menu
MESSAG.URG	
Maintenir < 3 sec. 	Effectuer l'effacement

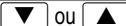
Déclarer et annuler le transmetteur d'appel d'urgence sur le téléphone

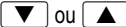
Déclarer le transmetteur d'appel d'urgence sur le téléphone





 5 transmetteurs maximum peuvent être déclarés sur le téléphone.

	Ouvrir le menu principal
 ou 	Sélectionner le sous-menu
PENDENTIF 	et valider
 ou 	Sélectionner le sous-menu
DECLARAT  ...	et valider
1 sec.  OK	Déclarer le transmetteur d'appel d'urgence

 Si la déclaration a échoué, l'écran affiche brièvement le message ERREUR.

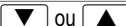

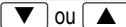
Annuler le transmetteur d'appel d'urgence sur le téléphone

 Les transmetteurs ne peuvent être annulés qu'ensemble ! Ensuite vous devez déclarer sur le téléphone les transmetteurs dont vous continuez d'avoir besoin !

	Ouvrir le menu principal
 ou 	Sélectionner le sous-menu
PENDENTIF 	et valider
 ou 	Sélectionner le sous-menu
EFFACER? 	et valider

Pile du transmetteur d'appel d'urgence

Contrôler la pile

1. Maintenez brièvement appuyée la touche d'appel d'urgence  du transmetteur. La LED capacité de pile est allumée pendant que vous appuyez sur cette touche.
2. Si cette LED ne s'allume plus en maintenant la touche d'appel d'urgence  appuyée, remplacez la pile.

Remplacer la pile

1. Retirez avec précaution les 4 vis situées au dos de l'appareil avec un petit tournevis cruciforme.
2. Ouvrez le cache du compartiment, p. ex. avec un tournevis étroit.
3. Remplacez la pile. N'utilisez qu'une pile de type A23 12V. Veillez à ce que la polarité soit correcte !
4. Refermez le cache du compartiment en sens inverse.

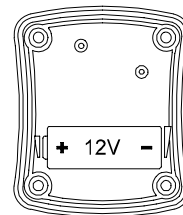

7 Installations PABX / Services confort

Touche R sur les installations PABX

Si votre téléphone est raccordé à une installation PABX, vous pouvez, via la **touche R**, bénéficier de certaines fonctions comme le transfert d'appels et le rappel automatique. Veuillez lire dans le mode d'emploi de votre installation PABX le temps de flash à paramétrer pour pouvoir utiliser ces fonctions. Le revendeur auprès duquel vous avez acheté l'installation vous informera si votre téléphone fonctionne parfaitement sur celle-ci.

Régler le temps de flash

 Menu page 38

Pause de numérotation

Dans le cas d'installations PABX, il faut composer auparavant un code réseau pour obtenir la tonalité. Sur quelques installations à postes supplémentaires plus anciennes, vous devez attendre quelques instants avant de pouvoir entendre la tonalité. Pour ces installations PABX, une pause de numérotation peut être insérée après le code réseau afin de pouvoir continuer à composer le numéro directement sans attendre la tonalité.



Insérer une pause de numérotation
"P" s'affiche

Après le chiffre de la ligne principale, votre téléphone attend env. 3 secondes avant de composer le numéro d'appel proprement dit.



La pause peut également être enregistrée dans le répertoire lors de la saisie de numéros d'appel.

Touche R et services confort

Votre téléphone supporte des services confort de votre opérateur tels que le va-et-vient, la signalisation d'appel en instance et la conférence. Vous pouvez les utiliser via la **touche R**. Demandez à votre opérateur le temps de flash à paramétrer pour les utiliser. Contactez ce dernier pour activer ces services. Réglage du temps de flash  Page 38.

Affichage du numéro d'appel (CLIP¹)

Si cette fonction est disponible sur votre ligne téléphonique, le numéro d'appel du correspondant sera affiché dès que le téléphone sonnera. Si un numéro de téléphone est enregistré dans le répertoire, le nom qui lui est associé apparaît également dans la liste d'appels.



Si un nom a été émis pour un contact du répertoire, celui-ci sera reproduit entre les premières sonneries. Ainsi vous n'avez pas besoin d'aller vers le téléphone pour voir qui vous appelle.

Si votre correspondant a bloqué la transmission de son numéro, un message correspondant sera affiché. Le numéro d'appel ne peut pas être affiché et ne peut donc être enregistré dans la liste d'appels et de répétition des derniers numéros.



L'affichage du numéro d'appel est un service optionnel de votre opérateur. Veuillez lui demander de plus amples informations.

¹ CLIP: Calling Line Identification Presentation







Structure du menu

8 Structure du menu

Menu principal

Vous accédez au menu principal en appuyant sur la touche .

Confirmer chaque saisie avec la touche  !

HEURE/DATE	 /  pour modifier les chiffres
SERVICES	KEY 1,2
	avec  /  sélectionner le chiffre 1 ou 2 ¹
	 Saisir un numéro  Saisir un nom
FV / DC ²	FV / DC
NVX APP L ³	ON / OFF
TOUCHE R ⁴	100 / 300 / 600
BIP	ON / OFF
CONTRASTE	1 / 2 / 3 / 4
TÉMOIN SON ⁵	ON / OFF
MESSAG.URG	Le message d'urgence est annoncé
SILENC.URG	ON / OFF
URGENCE	ON / OFF
BOOST BLOQ	ON / OFF



¹ Le chiffre sélectionné clignote.

² Système de numérotation multifréquence (MFV) (système de numérotation par tonalité) et système de numérotation par impulsions (IWW)

³ Fixe si, lors de nouveaux appels, la LED appel/appel d'urgence doit s'allumer dans la liste des appels/de répétition des derniers numéros.

⁴ en ms

⁵ Quand le téléphone sonne, la LED appel/appel d'urgence clignote/flasche plus fortement que normalement.

VOL.SON.	0 / 1 / 2 / 3 / 4
SON.	1 / 2 / 3
GUID VOCAL ⁶	ON / OFF
PENDENTIF	DECLARAT
	EFFACER?
TRANSM.NOM	
ENREG. NUM	 Saisir un numéro  Saisir un nom
LANGUE	DEUTSCH
	ENGLISH
	SVENSKA
	NEDERLANDS
	FRANCAIS
	ITALIANO

⁶ L'appui sur quelques touches est accompagné en plus d'une voix. Vous pouvez activer et désactiver la voix.

9 Répertoire

Vous pouvez enregistrer 99 numéros d'appel avec les noms afférents dans votre répertoire. Les numéros doivent contenir au maximum 22 chiffres ou positions, les nom au maximum 10 caractères ou positions.

- Saisissez toujours les numéros d'appel avec l'indicatif afin que le téléphone puisse aussi attribuer les communications locales entrantes à un contact du répertoire.
- Si la capacité de mémoire est épuisée, l'écran affiche le message suivant **PLEIN**. Pour créer de la place, vous devez effacer un autre contact.
- Les contacts du répertoire sont classés par ordre alphabétique. Pour accéder directement au contact désiré, appuyez sur l'initiale correspondante.
- Si vous n'appuyez pas sur une touche pendant 30 secondes quand vous ouvrez le répertoire, le téléphone retourne en mode veille.

Saisir un nom

Les noms doivent contenir au maximum 10 chiffres ou positions.

Des lettres sont gravées sur les touches numériques. En appuyant plusieurs fois sur la touche adéquate, vous pouvez saisir des lettres, des chiffres et des caractères spéciaux.



Pour saisir deux fois la même lettre, appuyez sur la lettre correspondante. Attendez que le curseur soit passé derrière la lettre. Puis tapez celle-ci une nouvelle fois.



Entrer un espace



Effacer des caractères

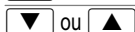

Changer la position du curseur (caractère clignotant)



Dans un texte existant, vous pouvez toujours entrer de nouveaux caractères devant la position du curseur.

Ajouter des contacts dans le répertoire

	Ouvrir le menu principal
ou	Sélectionner la fonction et valider
ENREG. NUM ,	Entrer le numéro (maxi 22 positions) et valider
, , ENREGISTRÉ ,	Saisir le nom (max. 10 positions) et valider
TRANSM.NOM	
Maintenir	Enregistrer le nom
Relâcher	



Un enregistrement doit durer 4 secondes au plus. Ensuite l'enregistrement est automatiquement interrompu.

Le nom enregistré est reproduit après l'enregistrement.



L'enregistrement d'un nom est optionnel et peut s'effectuer le cas échéant également séparément. Avantage présenté par l'enregistrement d'un nom : si ce numéro appelle, le nom sera reproduit 2 fois entre les premières sonneries. Ainsi vous n'avez pas besoin d'aller vers le téléphone pour voir qui vous appelle.

Modifier des contacts dans le répertoire

	Ouvrir le répertoire
ou	Sélectionner un contact
2 sec.	Introduire la modification
,	Modifier le numéro et valider
,	Modifier le nom et valider
Maintenir	Enregistrer le nom
Relâcher	

Répertoire

Supprimer des contacts du répertoire

Supprimer un contact

	Ouvrir le répertoire
ou	Sélectionner un contact
EFFACER?	Activer l'effacement
2 sec.	Valider l'effacement

Supprimer tous les contacts

	Ouvrir le répertoire
ou	Sélectionner un contact
2 sec. TOUT EFF.?	Activer l'effacement
2 sec.	Valider l'effacement

Réponse vocale pour les contacts du répertoire

Si vous avez enregistré des numéros dans votre répertoire, vous pouvez enregistrer un nom pour chaque contact. Si vous sélectionnez alors un contact dans le répertoire, votre enregistrement sera reproduit et vous entendez quel contact vous avez sélectionné.

Vous pouvez enregistrer des noms directement à l'ajout d'un contact, mais également ultérieurement pour des contacts existants.

Enregistrer un nom

	Ouvrir le menu principal
ou	Sélectionner la fonction
TRANSM.NOM ,	et valider
ou	Sélectionner un contact
Maintenir	Lancer l'enregistrement
Relâcher	Terminer l'enregistrement

Si vous ne relâchez pas la touche, l'enregistrement sera automatiquement terminé au bout de 4 secondes.

Effacer l'enregistrement

	Ouvrir le répertoire
ou	Sélectionner un contact
2 sec.	Introduire la modification
,	Modifier le numéro le cas échéant et valider
,	Modifier le nom le cas échéant et valider
TRANSM.NOM Maintenir	
«(ton de signalisation long)»	
Relâcher	Effacer la réponse vocale pour le contact du répertoire

10 Liste des appels et de répétition des derniers numéros

Dans l'ensemble, les 15 derniers numéros d'appels entrants et les 15 derniers numéros composés sont enregistrés dans une liste combinée des appels et de répétition des derniers numéros (nommée seulement «Liste» par la suite).

Nouveaux appels

Si de nouveaux appels sont présents dans la liste, l'icône du téléphone  s'affiche.

Si vous avez réglé dans le menu NVX APP L : ON , la LED appel/appel d'urgence clignotant rouge indique que de nouveaux appels ont été enregistrés dans la liste. Dès que vous avez consulté les contacts, la LED s'éteint.  Menu page 38

Faire afficher des numéros de la liste



Ouvrir la liste



C'est le contact le plus récent qui est affiché en premier.

ou



Ouvrir la liste et afficher le contact le plus récent

ou



Ouvrir la liste et afficher le contact le plus ancien



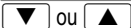

Sélectionner le contact venant avant le plus ancien et le consulter

ou



Sélectionner le contact et le consulter

- L'heure est affichée pour les contacts du jour. La date est affichée pour les contacts plus anciens.
- Si vous composez des numéros, l'icône de répétition des derniers numéros  s'affiche.

- Pour les numéros entrants, l'icône CID (engl. **C**aller **I**dentification) s'affiche.
- Pour les nouveaux numéros entrés qui n'ont pas été consultés auparavant, l'icône du téléphone  s'affiche.

Messages à l'écran

Écran	Description
PAS NUMERO	Il s'agit d'une communication internationale ou d'une communication d'une installation PABX.
PRIVE	Le correspondant a bloqué la transmission de son numéro d'appel ou il s'agit d'une communication d'une installation PABX.

Rappeler des numéros de la liste

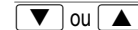

Ouvrir la liste et
Sélectionner le contact



Composer le numéro

ou

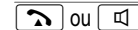

Composer le numéro
(fonction mains-libres)

Liste des appels et de répétition des derniers numéros

Sauvegarder dans le répertoire des numéros de la liste

Vous pouvez sauvegarder un numéro directement de la liste dans le répertoire.

ou Ouvrir la liste et Sélectionner le contact

Maintenir Lancer la sauvegarde

Modifier le numéro le cas échéant (maxi 22 positions) et valider

Saisir le nom (max. 10 positions) et valider

Maintenir

Relâcher Enregistrer le nom

Un enregistrement doit durer 4 secondes au plus. Ensuite l'enregistrement est automatiquement interrompu.

Dès que le numéro a été enregistré dans le répertoire avec un nom, celui-ci apparaît également dans la liste.

Effacer des numéros de la liste

Effacer des numéros individuels

ou Ouvrir la liste et Sélectionner le contact

Activer l'effacement

Maintenir Valider l'effacement

ou
 ou Annuler l'effacement

Effacer tous les numéros d'appel

Contrôlez avant d'effacer les numéros si les enregistrements ont été consultés.

ou Ouvrir la liste et Sélectionner le contact

2 sec. Activer l'effacement

Maintenir Valider l'effacement

ou
 ou Annuler l'effacement

11 En cas de problèmes

Ligne d'assistance directe

Si vous avez des problèmes avec votre téléphone, observez d'abord les remarques suivantes. S'il s'agit de problèmes techniques, vous pouvez vous adresser à notre hotline de service en Suisse au numéro de tél. 0900 00 1675 (frais Swisscom à la date d'impression de ce manuel : CHF 2,60/min). Si vous jouissez de droits de garantie, adressez-vous à votre revendeur. La durée de la garantie est de 2 ans.

Questions et réponses

Questions

Pas de communication téléphonique possible

Réponses

- Le téléphone n'est pas correctement raccordé ou est perturbé. N'utilisez que le câble de raccordement téléphonique fourni avec l'appareil.
- Le bloc secteur n'est pas branché ou il y a une panne totale de courant.

Certaines fonctions, par ex. l'amplification sur +40 dB ou le mode mains-libres ne fonctionnent pas

- Contrôlez si les piles sont insérées correctement, si le type de pile convient et si celles-ci sont chargées.

L'affichage du numéro d'appel (CLIP¹) ne fonctionne pas

- L'affichage du numéro d'appel est un service optionnel de votre opérateur. Veuillez lui demander de plus amples informations.
- Le correspondant a bloqué la transmission de son numéro.

Vous ne pouvez pas passer d'appel d'urgence automatique. À la place vous entendez un double son d'avertissement.

- Dans le menu URGENCE, OFF est activé.
- Aucun numéro n'est programmé sur les touches d'appel d'urgence.
- Le bloc secteur n'est pas enfiché correctement.
- IL n'y a pas 4 piles d'insérées dans le téléphone.
- Il n'y a pas de pile chargée dans le transmetteur d'appel d'urgence.

¹CLIP: Calling Line Identification Presentation = Affichage du numéro d'appel d'un correspondant.

Remarques d'entretien / Garantie

12 Remarques d'entretien / Garantie

Remarques d'entretien

- Nettoyez les surfaces du boîtier avec un chiffon doux et non pelucheux.
- N'utilisez pas de produits d'entretien ou de solvants.

Garantie

Les appareils SWITEL sont fabriqués et contrôlés selon des procédés les plus modernes qui soient. Des matériaux sélectionnés et des technologies de haut niveau garantissent un fonctionnement irréprochable et une longue durée de vie. La garantie n'est pas valable si l'exploitant du réseau téléphonique ou une installation PABX éventuellement intercalée est responsable du dysfonctionnement de l'appareil. La garantie ne s'applique pas aux piles et accumulateurs ou packs d'accumulateurs utilisés dans les produits. La durée de la garantie est de 24 mois à partir de la date d'achat.

Pendant la période de garantie, tous les défauts dus à des vices de matériel ou de fabrication seront éliminés gratuitement. Le droit à la garantie expire en cas d'intervention de l'acheteur ou de tiers. Les dommages provenant d'un maniement ou d'une manipulation incorrects, d'une usure naturelle, d'une mauvaise mise en place ou d'une mauvaise conservation, d'un raccordement ou d'une installation incorrects ainsi que d'un cas de force majeure ou autres influences extérieures sont exclus de la garantie. En cas de réclamations, nous nous réservons le droit de réparer, de remplacer les pièces défectueuses ou d'échanger l'appareil. Les composants remplacés ou les appareils échangés deviennent notre propriété. Les demandes de dommages et intérêts sont exclues tant qu'elles ne reposent pas sur l'intention ou une négligence grossière du fabricant.

Si votre appareil devait malgré tout présenter une défectuosité pendant la période de garantie, veuillez vous adresser, muni du reçu, exclusivement au magasin où vous avez acheté votre appareil SWITEL. Vous ne pouvez faire valoir vos droits à la garantie selon ces dispositions qu'exclusivement auprès de votre revendeur. Deux ans après l'achat et la remise de nos produits, il n'est plus possible de faire valoir les droits en matière de garantie.

Déclaration de conformité

Cet appareil répond aux exigences de la directive de l'Union européenne :

1999/5/CE : Directive sur les installations de radio et de télécommunication et la reconnaissance réciproque de leur conformité. La conformité avec la directive mentionnée ci-dessus est confirmée sur l'appareil par la marque CE.



Vous pouvez télécharger gratuitement la déclaration de conformité intégrale depuis notre site Internet www.switel.com.

13 Index

A

- Activer/Désactiver les sons de touche, 38
- Affichage de nouveaux appels, 41
- Affichage du numéro d'appel, 37
- Ajouter un contact, 39
- Amplifier le volume sonore de l'écouteur, 31
- Annonce d'appel d'urgence, 34, 35
- Annuler le transmetteur d'appel d'urgence sur le téléphone, 36
- Appareil de base, 27
- Appel d'urgence automatique, 34
- Appel d'urgence automatique via le téléphone, 35
- Appel d'urgence automatique via le transmetteur d'appel d'urgence, 35
- Appeler à l'aide des touches d'appel d'urgence, 32
- Appeler à l'aide des touches de sélection directe, 32
- Appeler à l'aide des touches de service, 33

B

- Bloc d'alimentation, 26

C

- Combiné, 29
- Comment téléphoner, 31
- Comment utiliser mon téléphone ?, 30
- Compatible avec les aides auditives, 26
- Composer des numéros de téléphone à partir du répertoire, 32
- Consignes de sécurité, 26
- Contacts dans le répertoire, 39
- Contenu du coffret, 27
- Contrôler la pile du transmetteur, 36
- Couper le micro de l'appel d'urgence automatique, 38

D

- Date, 28
- Déclaration de conformité, 44
- Déclarer le transmetteur d'appel d'urgence sur le téléphone, 36
- Désactiver l'appel d'urgence automatique, 38
- Durée de la communication, 31

E

- Écouter l'annonce d'appel d'urgence, 35
- Écran, 29
- Effacer des numéros de la liste, 42
- Effacer l'annonce d'appel d'urgence, 36
- Effacer l'enregistrement, 40
- Éléments de manipulation, 29
- Élimination d'erreurs, 43
- Enregistrer l'annonce d'appel d'urgence, 35
- Enregistrer un nom, 40

F

- Faire afficher des numéros de la liste, 41
- Faire annoncer le message d'urgence, 38
- Fin de l'appel d'urgence automatique, 35
- Fonction mains-libres, 33

G

- Garantie, 44

H

- Haut-parleur, 29
- Heure, 28

I

- Icônes d'écran, 30
- Insérer les piles, 28
- Installations PABX, 37

L

- Lancer l'appel d'urgence, 35
- LED amplificateur, 29
- LED appel/appel d'urgence, 29, 41
- LED capacité de la batterie, 29
- LED mains-libres, 29
- Lieu d'installation, 26
- Ligne d'assistance directe, 43
- Liste des appels et de répétition des derniers numéros, 41

M

- Menu principal, 38
- Messages à l'écran, 41
- Microphone, 29
- Mise en service, 27
- Modifier, 39
- Montage mural, 28

N

- Navigation dans le menu, 30
- Notations, 30
- Numérotation multifréquence - MFV, 38
- Numérotation par impulsions, 38
- Numérotation par impulsions - IWV, 38
- Numérotation par tonalité, 38

P

- Pause de numérotation, 37
- Prendre un appel, 31
- Problèmes, 43
- Programmer les touches d'appel d'urgence, 32
- Programmer les touches de sélection directe, 32
- Programmer les touches de service, 33

Q

- Que faire des appareils hors d'usage ?, 26
- Questions et réponses, 43

Index

R

- Rappeler des appels en absence, 32
- Rappeler des numéros de la liste, 41
- Régler la date et l'heure, 38
- Régler la langue, 38
- Régler la sonnerie, 38
- Régler le contraste, 38
- Régler le contraste de l'écran, 38
- Régler le temps de flash, 37, 38
- Régler le volume de la sonnerie, 31, 38
- Régler le volume sonore de l'écouteur, 31
- Régulateur à coulisse pour la régulation du son, 29
- Régulateur à coulisse pour le volume de l'écouteur, 29
- Régulation du son, 29, 31
- Remarques d'entretien, 44
- Remplacer la pile du transmetteur, 36
- Répertoire, 39
- Répétition des derniers numéros, 32
- Réponse vocale pour les contacts du répertoire, 40
- Représentations, 30

S

- Saisie de texte, 39
- Saisir le nom, 39
- Sauvegarder, 39
- Sauvegarder dans le répertoire des numéros de la liste, 42
- Sélection directe, 32
- Sélectionner une sonnerie, 38
- Services confort, 37
- Services d'alarme, 34
- Signal d'appel d'urgence, 34
- Structure du menu, 38
- Supprimer, 40
- Système de numérotation multifréquence, 38

T

- Téléphoner, 31
- Terminer l'appel automatique d'urgence par la personne émettant l'appel, 35
- Terminer l'appel automatique d'urgence par la personne recevant l'appel, 35
- Terminer la communication, 31
- Touche «vers le bas», 29
- Touche «vers le haut», 29
- Touche amplificateur (+40 dB), 29
- Touche communication/OK, 29
- Touche d'appel d'urgence, 29
- Touche de menu, 29
- Touche dièse, 29
- Touche Effacement/Retour, 29
- Touche étoile, 29
- Touche mains-libres, 29
- Touche R, 29
- Touche R et services confort, 37
- Touche R sur les installations PABX, 37
- Touche répertoire, 29
- Touches d'appel d'urgence, 29, 32
- Touches de sélection directe, 29
- Touches de service, 29, 33
- Touches numériques, 29

U

- Utilisation conforme aux prescriptions, 26

V

- Volume sonore en mode mains libres, 33

1	Indicazioni di sicurezza	48
2	Messa in funzione del telefono	49
3	Elementi di comando	51
4	Come funziona il mio telefono?	52
5	Compiere telefonate	53
6	Chiamata d'emergenza automatica	56
7	Impianti telefonici interni / Servizi aggiuntivi	59
8	Struttura di menu	60
9	Rubrica telefonica	61
10	Lista chiamate/ripetizione di chiamata	63
11	In presenza di problemi	65
12	Consigli per la cura / Garanzia	66
13	Indice alfabetico	67

Indicazioni di sicurezza

1 Indicazioni di sicurezza

Leggere attentamente le presenti istruzioni per l'uso.

Scopo d'impiego

Il presente telefono consente di eseguire chiamate in una rete telefonica. Qualsiasi altro impiego è considerato non conforme agli usi previsti. Non sono consentite modifiche o trasformazioni non autorizzate. Non aprire per nessuna ragione l'apparecchio autonomamente, né compiere riparazioni di propria iniziativa.

Luogo di installazione

Evitare un'esposizione a fumo, polvere, vibrazioni, sostanze chimiche, umidità, calore e raggi solari diretti.

Alimentatore di rete



Attenzione: Utilizzare solo l'alimentatore di rete fornito visto che altri alimentatori di rete potrebbero addirittura danneggiare il telefono. Non ostacolare il libero accesso all'alimentatore di rete con mobili o altri oggetti simili.

Compatibilità con protesi acustiche

Il telefono dotato di ricevitore Premium è perfettamente compatibile con il maggior numero di protesi acustiche presenti sul mercato. A causa del grande numero di modelli non è possibile garantire il perfetto funzionamento del telefono con qualsiasi protesi acustica.



Attenzione: Il telefono è in grado di riprodurre volumi elevati con amplificatore attivato e regolatore di volume al massimo livello. È pertanto richiesta particolare cautela in caso di passaggio del dispositivo tra utilizzatori con udito normale e utilizzatori con udito ridotto.

Smaltimento

Smaltire l'apparecchio consegnandolo in uno dei punti di raccolta istituiti dalla propria società di smaltimento rifiuti comunale (ad es. centro di riciclo materiali). La legge sugli apparecchi elettrici ed elettronici prescrive ai proprietari di apparecchi esauriti la consegna di tutti gli **apparecchi elettrici ed elettronici** in un centro di rilievo rifiuti in raccolta differenziata. Il simbolo indica che non è assolutamente consentito smaltire l'apparecchio assieme ai normali rifiuti domestici!



Batterie ricaricabili e pile possono provocare danni alla salute e all'ambiente!



Non aprire, danneggiare, ingerire o disperdere nell'ambiente batterie ricaricabili e pile. Queste possono contenere metalli pesanti nocivi e dannosi per l'ambiente. Per legge sussiste l'obbligo di smaltire correttamente batterie ricaricabili e pile utilizzando gli appositi contenitori di raccolta in uso presso i rivenditori di batterie. Lo smaltimento è gratuito. I simboli indicano che non è assolutamente consentito gettare batterie ricaricabili e pile nei rifiuti domestici, consegnandoli ai fini dello smaltimento nei rispettivi punti di raccolta.

Smaltire **confezioni ed imballaggi** secondo quanto indicato dalle norme in vigore a livello locale.

2 Messa in funzione del telefono

Indicazioni di sicurezza



Attenzione: Prima della messa in funzione, leggere attentamente le indicazioni di sicurezza nel capitolo 1.

Verificare il contenuto della confezione

La confezione include:

Contenuto	TF 520
Unità base	1
Alimentatore di rete	1
Ricevitore	1
Cavo a spirale per ricevitore	1
Dispositivo di telesoccorso applicabile su braccio o al collo (a prova di spruzzi)	1
Cavo di collegamento telefonico	1
Pile tipo AA 6 V	4
Pila tipo A23 12 V (integrata nel dispositivo di telesoccorso)	1
Supporto per montaggio a parete	1
Istruzioni per l'uso	1

Avvertimento importante

La stazione base del vostro apparecchio è dotata di un circuito di alimentazione rete ad efficienza energetica (Input 230 V_{AC}, Output 9 V_{DC}, 300 mA). Il carico nullo è pari a circa 0,1 W. L'efficienza media è pari > 68,46 %. L'assorbimento di potenza ammonta a max. 3,91 W.

Collegare l'unità base

Procedere al collegamento del telefono seguendo quanto raffigurato sul disegno. Utilizzare per motivi di sicurezza solo l'alimentatore di rete oltre al cavo di collegamento telefonico forniti in dotazione.

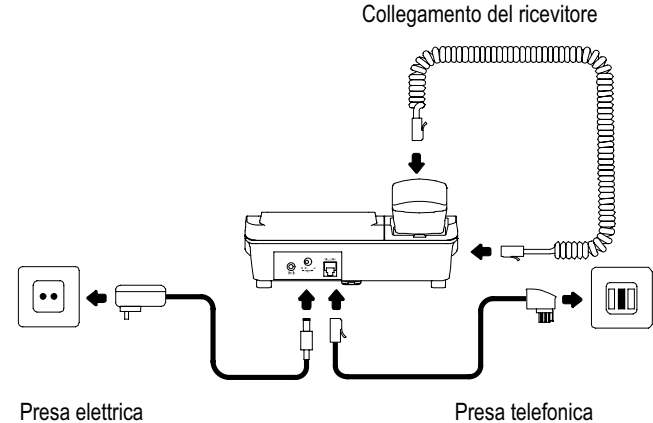

L'impiego del telefono è possibile con o senza alimentatore di rete. Volendo utilizzare il telefono senza alimentatore, assicurarsi che le pile siano inserite correttamente, del tipo giusto e cariche.

Messa in funzione del telefono

Inserimento delle pile

 Evitare di collegare il telefono alla presa telefonica e/a alla rete durante l'inserimento o la sostituzione delle pile.

Inserire le pile nell'apposito vano batterie precedentemente aperto. Utilizzare solo pile di tipo AA 6 V. Osservare la corretta polarità! Chiudere il vano pile.

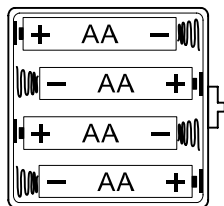

 Il funzionamento del dispositivo non richiede necessariamente l'inserimento di pile. Il telefono è infatti utilizzabile con o senza pile. Volendo utilizzare il telefono senza pile è assolutamente necessario collegare l'alimentatore di rete.

 **Attenzione:** Si tenga presente che utilizzando il telefono senza pile, in caso di una caduta di tensione non è possibile compiere telefonate o lanciare una chiamata di soccorso!

Con pile non più completamente cariche o scariche, nel display viene visualizzato il simbolo pila . Sostituire le pile.

Impostare data e ora

 Menu pag. 60

Impostazioni varie

Il menu consente di svolgere varie impostazioni sul telefono, riferite ad es. a procedura di selezione (TON/IMPULS), suoneria (SUONERIA), tono dei tasti (TONO TASTI), contrasto di display (CONTRASTO), annuncio vocale dei tasti premuti (ANNUNC.VOC), significato di LED illuminati e altro

 Menu pag. 60.

Impianti telefonici interni

A pag. 59 sono riportate ulteriori informazioni riguardo l'eventuale collegamento del telefono ad un impianto telefonico interno.

Montaggio a parete

Introdurre i nasetti di guida (1) del supporto per montaggio a parete (2) nelle scanalature (3) presenti sul retro del telefono. Spingere il supporto per montaggio a parete (2) 10 mm verso sopra facendolo scattare in posizione. Effettuare un foro e lasciare uscire una vite di ca. 5 mm dalla parete. Infilare l'attacco (4) del dispositivo di montaggio a parete (2) sulla vite e abbassare il telefono.

 **Attenzione:** Prima di effettuare il foro, escludere la presenza di fili e cavi.

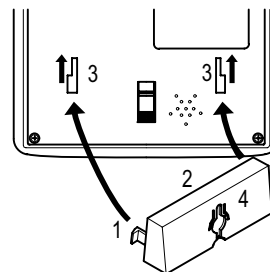



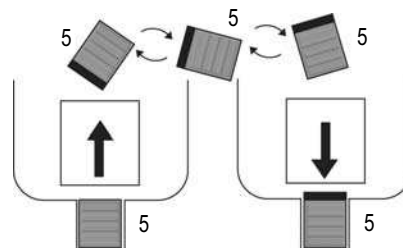







Girare il gancio di fissaggio (5) nell'alloggiamento del ricevitore in modo da potervi agganciare il ricevitore.



3 Elementi di comando

Telefono

- | | | | |
|----|--|----|--|
| 1 | Selettore per volume del ricevitore | 13 | Tasto di menu  |
| 2 | Altoparlante (per funzione vivavoce) | 14 | Tasto R  |
| 3 | Ricevitore | 15 | Tasto di selezione e ripetizione di chiamata  |
| 4 | Tasto rubrica  | 16 | LED amplificatore |
| 5 | Tasto Cancella/Indietro  | 17 | Tasto amplificatore (+40 dB)  |
| 6 | Tasto di chiamata/OK  | 18 | Tasto vivavoce  |
| 7 | Tasto giù/Tasto aumento volume del vivavoce  | 19 | LED vivavoce |
| 8 | Tasto su/Tasto riduzione volume del vivavoce  | 20 | Microfono |
| 9 | Display | 21 | Tasti numerici (inclusi tasti asterisco e cancelletto) |
| 10 | LED di chiamata/chiamata d'emergenza | |  |
| 11 | Grandi tasti d'emergenza rossi (n. 3) M1 M2 M3 | 22 | Tasti di servizio 1 2 ABC |
| 12 | Tasti di selezione diretta (n. 5) M1 M2 M3 M4 M5 | 23 | Selettore per regolazione del suono |

Dispositivo di telesoccorso

- 24 Tasto d'emergenza 
- 25 LED capacità delle pile

I tasti riportati nelle presenti istruzioni per l'uso sono raffigurati con un contorno uniforme. Con riserva di modifiche per tasti e simboli visualizzati sul display del telefono rispetto a tasti e simboli di display qui raffigurati.

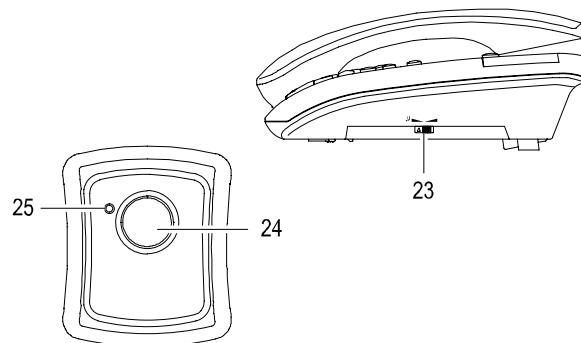
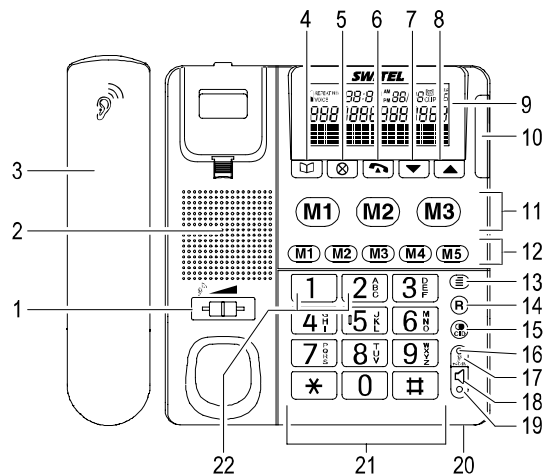

Come funziona il mio telefono?

4 Come funziona il mio telefono?

Rappresentazioni e modi di scrittura

	Immettere cifre o lettere
	Premere brevemente il tasto raffigurato
2 x	Premere brevemente 2x il tasto raffigurato
2 sec.	Premere 2 secondi il tasto raffigurato
tenere	Tenere premuto il tasto raffigurato
rilasciare	Rilasciare il tasto raffigurato
	Telefono squilla
	Sollevere il ricevitore
	Agganciare il ricevitore
	Registrare un testo
	Testo lampeggiante sul display
LINGUA oppure	Testo o simboli sul display

Simboli sul display

Il display si illumina brevemente dopo aver premuto un tasto e per un breve intervallo successivo.

Simbolo	Descrizione
	In assenza di pile nell'unità base e quando le pile inserite non sono più del tutto cariche o sono scariche, sul display compare il simbolo batteria. Inserire pile del tutto cariche pag. 50.
	Con volume della suoneria disattivato (livello 0, muto, sul display compare il simbolo del campanello sbarrato pag. 53.
	Con funzione vivavoce attivata, il simbolo vivavoce è visualizzato sul display pag. 55
	In presenza di nuove chiamate nella lista chiamate/ripetizione di chiamata, sul display compare il simbolo del telefono pag. 63

Simbolo	Descrizione
	In caso di lancio automatico della chiamata d'emergenza e di selezione non ancora conclusa, sul display compare il simbolo di telesoccorso pag. 56.
CID	Una volta visualizzati nella lista chiamate/ripetizione di chiamata i recapiti telefonici da cui era stato precedentemente chiamato, sul display compare il simbolo CID pag. 63
	Una volta visualizzati nella lista chiamate/ripetizione di chiamata i recapiti telefonici precedentemente selezionati, sul display compare il simbolo di ripetizione di chiamata pag. 63
	Con amplificazione del volume del ricevitore impostato in modo permanente su +40 dB, sul display compare il simbolo dell'amplificatore pag. 53

Navigare nel menu

I vari menu consentono di accedere alle funzioni del telefono. Il percorso da seguire per giungere alla funzione desiderata è indicato dalla struttura di menu pag. 60.

	Aprire il menu principale
oppure	Selezionare il sottomenu richiesto
	Aprire il sottomenu
oppure	Selezionare l'impostazione richiesta
	Inserire cifre o lettere tramite tastiera
	Confermare l'immissione
	Interrompere le procedure di programmazione e memorizzazione e tornare alla modalità di stand-by





Ogni singolo processo si interrompe automaticamente se entro 15 secondi non segue una immissione.

5 Compiere telefonate

Ricevere una chiamata



Con chiamata in arrivo, il LED di chiamata/chiamata d'emergenza lampeggia.



 La frequenza di lampeggia del LED di chiamata/chiamata d'emergenza è aumentabile  Menu pag. 60 (FLASH CHIA).

,  oppure  Ricevere una chiamata

oppure

 Ricevere una chiamata
(funzione di vivavoce)

 Se la propria linea telefonica è abilitata all'inoltro del numero del chiamante (CLIP)  pag. 59) e avendo selezionato tramite menu ANNUNC.VOC.ON, lo squillo è preceduto dall'annuncio del numero telefonico del chiamante.

 Se il numero telefonico del chiamante risulta memorizzato in rubrica  pag. 61) con un rispettivo nome, tra i primi due squilli viene riprodotto il nome registrato.

Visualizzare la durata di conversazione

Durante lo svolgimento di una chiamata, la durata di conversazione è visualizzata in minuti e secondi sul display.

Concludere la chiamata

 oppure  Concludere la chiamata

oppure (con funzione vivavoce attiva)

 Concludere la chiamata

Compiere telefonate

 Immettere un numero di chiamata
(max. 22 cifre)

 In caso di immissione errata cancellare
l'ultima cifra

 Selezionare un numero di chiamata

oppure

 oppure 

Selezionare un numero di chiamata
(funzione vivavoce)

 È altresì possibile sollevare prima il ricevitore e ottenere quindi il segnale di linea libera. Le cifre immesse per la composizione del numero di chiamata desiderato sono immediatamente selezionate. Nel corso di una simile chiamata non è possibile eseguire la correzione di singole cifre che compongono il numero di chiamata.

Impostare il volume di squillo

Il volume di squillo è regolabile tramite menu in 5 livelli  pag. 60:

- Livello 0: volume di squillo disattivato (MUTE)
- Livello 1: volume di squillo basso
- Livello 4: volume di squillo alto

Impostare il volume del ricevitore

Regolare il volume del ricevitore tramite selettore presente sotto il ricevitore agganciato:

- Selettore a sinistra: volume del ricevitore è più basso.
- Selettore a destra: volume del ricevitore è più alto.

Aumentare il volume del ricevitore a +40 dB

Premendo il tasto di amplificazione è possibile aumentare il volume del ricevitore a +40 dB.

 Aumentare il volume del ricevitore

 Disattivare l'amplificazione

Il telefono si lascia impostare tramite menu in modo da attivare direttamente l'amplificatore su +40 dB senza dover precedentemente premere il tasto di amplificazione. Selezionare nel menu AMPLI.BLOC:ON

 Menu pag. 60.

Regolazione del suono per il ricevitore

 La regolazione del suono funziona solo con amplificazione del volume del ricevitore attivata su +40 dB (LED dell'amplificatore acceso).



Per regolare il suono del ricevitore, adoperare il cursore scorrevole presente sulla destra dell'involucro.

Compiere telefonate

Ripetizione di chiamata e richiamata di chiamate perse

Il telefono memorizza gli ultimi 15 numeri di chiamata in una lista chiamate/ripetizione di chiamata ☞ pag. 63.

 Aprire la lista

 oppure  Selezionare il numero telefonico richiesto



 Selezionare il numero telefonico



- Numeri telefonici chiamati sono visualizzati sul display con il simbolo di ripetizione di chiamata .
- Numeri telefonici ricevuti sono visualizzati sul display con il simbolo CID (inglese per **Caller Identification**).

Selezionare numeri dalla rubrica

La funzione richiede la precedente memorizzazione di numeri di chiamata in rubrica ☞ pag. 61.

 Aprire la rubrica

 oppure  Selezionare una voce



 oppure  Instaurare un collegamento



Selezione diretta

Il telefono è dotato di 5 numeri di selezione diretta (M1 - M5) (M = inglese per Memory) su cui è possibile memorizzare numeri telefonici utilizzati frequentemente.

Programmare i tasti di selezione diretta



 Immettere un numero telefonico (max. 22 cifre)



tenere , , ,

 oppure   Programmare un numero su un tasto di selezione diretta

 Numeri telefonici programmati non sono cancellabili, possono essere solo sovrascritti con nuovi numeri telefonici.

Telefonare con i tasti di selezione diretta

, , ,

 oppure  Premere il tasto di selezione diretta richiesto

 oppure  Instaurare un collegamento



Tasti d'emergenza

Il telefono presenta 3 grandi tasti d'emergenza con cui è possibile selezionare dei numeri telefonici in modo molto semplice.

Programmare i tasti d'emergenza

 Si tenga presente che in caso di lancio automatico di una chiamata d'emergenza, i numeri di chiamata programmati sui 3 tasti d'emergenza sono composti uno dopo l'altro, incominciando con M1 ☞ pag. 56.

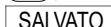

 Immettere un numero telefonico (max. 22 cifre)

tenere , ,

oppure   Programmare un numero telefonico sul tasto d'emergenza

 Numeri telefonici programmati non sono cancellabili, possono essere solo sovrascritti con nuovi numeri telefonici. Per modificare la posizione del cursore in una voce già memorizzata, premere il tasto su/giù. Per cancellare segni, premere il tasto Cancella/Indietro.

Telefonare con i tasti d'emergenza











,  oppure  Premere il tasto d'emergenza richiesto

 oppure  Instaurare un collegamento

Tasti di servizio

I tasti **1** e **2^{ABC}** prevedono la memorizzazione di numeri di servizio speciali, che possono quindi essere selezionati in modo semplice e rapido.



Programmare i tasti di servizio

	Aprire il menu principale
 oppure 	Selezionare la funzione e confermare
SERVIZI, 	
KEY 1,2,  oppure 	Selezionare il tasto 1 o 2 (la cifra del tasto attivo lampeggia) e confermare
	
 	Immettere il numero di chiamata (max. 22 cifre) e confermare
  , SALVATO	Immettere il nome (max. 10 lettere) e confermare



Numeri telefonici programmati non sono cancellabili, possono essere solo sovrascritti con nuovi numeri telefonici. Per modificare la posizione del cursore in una voce già memorizzata, premere il tasto su/giù. Per cancellare segni, premere il tasto Cancella/Indietro.

Telefonare con i tasti di servizio

tenere 1 oppure 2^{ABC}	Tenere premuto il tasto di servizio richiesto finché viene visualizzato il numero telefonico d'interesse
 oppure 	Instaurare un collegamento

Funzione vivavoce

Utilizzare la funzione vivavoce per ascoltare il partner di chiamata attraverso l'altoparlante e poter condurre la conversazione senza dover accostare il ricevitore all'orecchio.

	Attivare la funzione vivavoce con chiamata in corso
---	---

Con funzione vivavoce attivata, il rispettivo LED si accende di rosso. Parlare in direzione del microfono. Il microfono si trova nella parte anteriore destra dell'unità base.

	Disattivare la funzione vivavoce con chiamata in corso
---	--





È possibile passare a piacere dalla funzione vivavoce alla conversazione attraverso il ricevitore e viceversa. Importante: Il ricevitore deve essere in tal caso sollevato dall'unità base!



Rumori di sottofondo, ad es. musica ad alto volume, possono compromettere la qualità audio del dispositivo vivavoce.

Impostare il volume del dispositivo vivavoce

Il volume del dispositivo vivavoce può essere impostato tramite i tasti su e giù in 8 livelli da volume basso (livello 1) a volume alto (livello 8).

	Ridurre il volume del dispositivo vivavoce
	Aumentare il volume del dispositivo vivavoce

Chiamata d'emergenza automatica

6 Chiamata d'emergenza automatica



Il dispositivo rilascia una chiamata d'emergenza automatica solo

- con menu CHIAM.EMER:ON attivato ☞ Menu pag. 60,
- e telefono collegato alla rete tramite alimentatore
- o alimentato da 4 pile cariche e dispositivo di telesoccorso dotato di 1 pila carica.

La funzione di chiamata d'emergenza automatica consente di lanciare una richiesta di telesoccorso a speciali servizi d'emergenza domestica o a determinate persone.



Sono numerosi i servizi d'emergenza domestica idonei, come ad es. Croce rossa, Croce rossa maltese, Soccorso dell'Ordine di S. Giovanni. In alcuni paesi l'uso di servizi d'emergenza domestica sono soggetti a pagamento.

Il presente telefono d'emergenza può anche essere utilizzato come dispositivo d'emergenza circoscritto alla propria famiglia.

Funzionamento della chiamata d'emergenza automatica

Una volta lanciata una chiamata d'emergenza automatica, il telefono si comporta come segue:

- Per 15 secondi la base del dispositivo emette un forte segnale d'emergenza. Contemporaneamente il LED di chiamata/chiamata d'emergenza lampeggia.



Avendo precedentemente attivato il menu EMERG.SILE:ON, il dispositivo non emette invece il segnale d'emergenza. In questo caso lampeggia solo il LED di chiamata/chiamata d'emergenza.

- La funzione vivavoce del dispositivo è attivata.
- I numeri di chiamata memorizzati sui 3 tasti di chiamata d'emergenza sono selezionati uno dopo l'altro.
- Innanzitutto viene selezionato il numero di chiamata memorizzato sul grande tasto rosso **(M1)**.
- Il telefono squilla max. 60 secondi. In caso nessuno risponda alla chiamata entro questo tempo, la telefonata è interrotta.
- La stazione base emette di nuovo per 15 secondi il segnale d'emergenza.

- Il dispositivo procede ora alla selezione del numero d'emergenza memorizzato sul grande tasto rosso **(M2)**.
- Se anche qui non risponde nessuno, il dispositivo procede secondo la stessa modalità rilasciando per 15 secondi il segnale d'emergenza e selezionando quindi il numero d'emergenza memorizzato sul grande tasto rosso **(M3)**.



Non avendo memorizzato alcun numero telefonico su uno dei 3 grandi tasti rossi **(M1)**, **(M2)** o **(M3)**, il dispositivo non seleziona alcun numero telefonico limitandosi invece solo al rilascio del segnale d'emergenza.

- Non appena qualcuno risponde alla chiamata, il dispositivo riproduce il messaggio d'emergenza a ciclo infinito.



La configurazione iniziale prevede il seguente messaggio d'emergenza predefinito: "Questa è un'emergenza. Per accettare premi zero." È anche possibile personalizzare il messaggio d'emergenza e riprendere un proprio messaggio ☞ pag. 57.

- Premendo il tasto [0] sul telefono destinatario della chiamata d'emergenza, il messaggio d'emergenza è interrotto e il mittente della chiamata d'emergenza è collegato automaticamente. Il mittente della chiamata d'emergenza utilizza in tal caso il telefono attraverso il dispositivo vivavoce.



Se nessuno risponde alla chiamata, il telefono avvia un nuovo ciclo chiamando di nuovo i numeri d'emergenza memorizzati sui grandi tasti rossi **(M1)**, **(M2)** e **(M3)**. Il telefono effettua 4 cicli con una durata complessiva di ca. 15 minuti. Se nessuno accetta la chiamata d'emergenza, il dispositivo conclude automaticamente il lancio di una chiamata d'emergenza.

Programmare numeri telefonici sui tasti d'emergenza

pag. 54

Avviare una chiamata d'emergenza automatica



Per poter richiedere aiuto esterno è indispensabile aver precedentemente programmato correttamente i numeri di chiamata previsti.

Chiamata d'emergenza automatica tramite dispositivo di telesoccorso



Assicurarsi che la pila inserita nel dispositivo di telesoccorso sia sempre carica, il dispositivo di telesoccorso sia registrato presso il telefono e si trovi entro la portata del telefono!

Tenere premuto sul dispositivo di telesoccorso il tasto d'emergenza per min. 1 secondo.



Fintanto che si tiene premuto il tasto d'emergenza, il LED relativo alla capacità della pila risulta acceso.

Chiamata d'emergenza automatica tramite telefono

tenere **M1**, **M2** o **M3** Avviare la chiamata d'emergenza automatica

Concludere la chiamata d'emergenza automatica da parte del rispettivo mittente

3 sec. Concludere la chiamata d'emergenza automatica

oppure



Concludere la chiamata d'emergenza automatica

oppure



Concludere la chiamata d'emergenza automatica

Concludere la chiamata d'emergenza automatica da parte del rispettivo destinatario



Accettare la chiamata d'emergenza automatica



Accettare la chiamata d'emergenza automatica



Parlare con il mittente della chiamata d'emergenza



Concludere la chiamata d'emergenza

Conclusione automatica della chiamata d'emergenza

La chiamata d'emergenza si conclude automaticamente non raggiungendo nessuno sui 3 numeri telefonici memorizzati sui tasti d'emergenza.

Messaggio d'emergenza

La configurazione iniziale prevede il seguente messaggio d'emergenza predefinito: "Questa è un'emergenza. Per accettare premi zero." Questo messaggio d'emergenza può essere sostituito da un messaggio d'emergenza personale.

Il messaggio d'emergenza è riprodotto fintanto che qualcuno non accetta la chiamata premendo sul proprio telefono il tasto [0]. Si consiglia infatti di concludere il proprio messaggio d'emergenza sempre con la frase: "**Per accettare questa chiamata d'emergenza, premere il tasto 0!**".



Fare altresì attenzione affinché il chiamato sia in grado di riconoscere il mittente della chiamata d'emergenza. Indicare nel messaggio che si tratta di una chiamata d'emergenza e che si ha bisogno di aiuto.

Riprodurre il messaggio d'emergenza



Aprire il menu principale



oppure



Selezionare il sottomenu

MESSAG.SOS



Riprodurre il messaggio d'emergenza

Chiamata d'emergenza automatica

Registrare il messaggio d'emergenza

 Il messaggio d'emergenza può avere una lunghezza max. di 30 secondi.

 Aprire il menu principale

 oppure  Selezionare il sottomenu

MESSAG.SOS

tenere   Avviare la registrazione

rilasciare  Concludere la registrazione

Cancellare il messaggio d'emergenza

 Aprire il menu principale

 oppure  Selezionare il sottomenu

MESSAG.SOS

tenere < 3 sec.  Procedere alla cancellazione

Registrare e annullare la registrazione del dispositivo di telesoccorso sul telefono

Registrare il dispositivo di telesoccorso sul telefono

 È possibile registrare max. 5 dispositivi di telesoccorso presso il telefono.

 Aprire il menu principale

 oppure  Selezionare il sottomenu e confermare

TRASMETI. 

 oppure  Selezionare il sottomenu

REGISTRA  ... e confermare

1 sec.  OK Registrare il dispositivo di telesoccorso

 In caso di registrazione eseguita con esito negativo, sul display compare brevemente l'indicazione ERRORE.

Annullare la registrazione del dispositivo di telesoccorso sul telefono

 È possibile annullare la registrazione di tutti i dispositivi di telesoccorso contemporaneamente! Fatto questo, il dispositivo di telesoccorso richiesto andrà nuovamente registrato sul telefono!

 Aprire il menu principale

 oppure  Selezionare il sottomenu e confermare



TRASMETI. 

 oppure  Selezionare il sottomenu

CANCELLA?  e confermare

Pila del dispositivo di telesoccorso

Controllare la pila

1. Tenere brevemente premuto il tasto d'emergenza  sul dispositivo di telesoccorso. Il LED relativo alla capacità della pila rimane acceso fintanto che si preme il tasto.
2. Se il LED relativo alla capacità della pila non si accende mentre si preme il tasto d'emergenza , sostituire la pila.

Sostituire la pila

1. Rimuovere le 4 viti sul retro del dispositivo di telesoccorso con un piccolo cacciavite a croce.
2. Aprire il coperchio del vano batteria ad es. con l'ausilio di un cacciavite a taglio.
3. Sostituire la pila. Utilizzare una batteria di tipo A23 12V. Osservare la corretta polarità!
4. Chiudere il coperchio del vano batteria in ordine inverso.

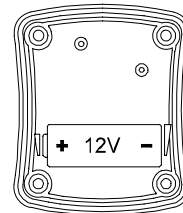

7 Impianti telefonici interni / Servizi aggiuntivi

Tasto R in impianti telefonici interni

Avendo collegato il telefono ad un impianto telefonico interno, il **tasto R** consente di accedere a tutte le altre funzioni disponibili come per es. trasferimento di chiamata e funzione di richiamata automatica. Consultare le istruzioni per l'uso del proprio impianto telefonico interno per individuare il tempo flash richiesto. Il rivenditore autorizzato è in grado di indicare se il telefono acquistato funzionerà senza alcun problema nel proprio impianto telefonico interno.

Impostare il tempo flash

☞ Menu pag. 60

Pausa di selezione

In presenza di impianti telefonici interni è necessario preselezionare un numero di accesso alla rete esterna per ottenere un segnale di linea libera prima di compiere una telefonata. Alcuni impianti telefonici interni di vecchia data richiedono un intervallo di tempo di poco superiore prima di trasmettere un segnale di libero. Per questi impianti telefonici interni è possibile inserire una pausa di selezione dopo il numero di accesso alla linea esterna in modo da poter proseguire con la selezione del numero senza dover attendere il segnale di libero.



Inserire una pausa di selezione
"P" è visualizzato sul display

Dopo aver selezionato il numero di accesso alla rete esterna, il telefono attende ca. 3 secondi prima di procedere alla selezione del numero di chiamata vero e proprio.



La pausa può essere prevista anche durante l'immissione di un numero telefonico in rubrica.

Tasto R e servizi aggiuntivi

Il telefono supporta servizi aggiuntivi offerti dal proprio gestore di rete telefonica come ad es. le funzioni di chiamata in attesa, avviso di chiamata e chiamata in conferenza. Il **tasto R** consente di accedere a questi servizi aggiuntivi. Il proprio gestore di rete telefonica fornisce informazioni sul tempo flash necessario all'utilizzo dei servizi aggiuntivi e sui requisiti di abilitazione ai servizi aggiuntivi. Impostare il tempo flash ☞ pagina 60.

Visualizzazione del numero di chiamata (CLIP¹)

A condizione che il collegamento telefonico disponga di questa funzione, l'apparecchio visualizza il numero telefonico del chiamante non appena il telefono squilla. Se il numero telefonico risulta memorizzato in rubrica, sul display compare anche il nome memorizzato.



Se ad una voce in rubrica è stato altresì abbinato un nome, tra i primi due squilli viene riprodotto il nome registrato. In questo modo si evita di doversi avvicinare al telefono per vedere chi chiama.

Se il chiamante ha soppresso la trasmissione del proprio numero di chiamata, il telefono visualizza un'apposita indicazione. Il numero telefonico non è visualizzato e pertanto non è neanche visualizzato nella lista chiamate/ripetizione di chiamata.



La visualizzazione del numero di chiamata è un servizio opzionale offerto dal proprio gestore di rete telefonica. Per informazioni rivolgersi al proprio gestore di rete telefonica.

¹ CLIP: Calling Line Identification Presentation







Struttura di menu

8 Struttura di menu

Menu principale

Per passare al menu principale, premere il tasto .

Confermare ogni immissione con il tasto .

ORA/DATA	 /  Per modificare le cifre
SERVIZI	KEY 1,2
	con  /  Selezionare la cifra 1 o 2 ¹
	 Immettere il numero  Immettere il nome
TON/IMPULS ²	MULTIFREQ/ DECADICA
LED CHIA.N ³	ON/OFF
DURA.FLASH ⁴	100 / 300 / 600
TONO TASTI	ON ON/OFFOFF
CONTRASTO	1 / 2 / 3 / 4
FLASH CHIA ⁵	ON/OFF
MESSAG.SOS	Il messaggio d'emergenza è riprodotto
EMERG.SILE	ON /OFF
CHIAM.EMER	ON /OFF
AMPLI.BLOC	ON /OFF



¹ La cifra selezionata lampeggia.

² Procedura di selezione multifrequenza (MF) e procedura di selezione decadica o a toni (DC)

³Definisce se fare lampeggiare il LED di chiamata/chiamata d'emergenza in caso di nuove chiamate nella lista chiamate/ripetizione di chiamata.

⁴ in ms

⁵ Con telefono che squilla, il LED di chiamata/chiamata d'emergenza lampeggia/si accende con maggiore intensità.

VOL.SUONE.	0 / 1 / 2 / 3 / 4
SUONERIA	1 / 2 / 3
ANNUNC.VOC ⁶	ON/OFF
TRASMETI.	REGISTRA
	CANCELLA?
RECORD NOM	
SALVA NUM	 Immettere il numero  Immettere il nome
LINGUA	DEUTSCH
	ENGLISH
	SVENSKA
	NEDERLANDS
	FRANCAIS
	ITALIANO

⁶ La pressione di alcuni tasti è in più accompagnata da un annuncio vocale. La voce può essere attivata o disattivata.

9 Rubrica telefonica

Nella rubrica telefonica è possibile memorizzare 99 numeri di chiamata con i rispettivi nomi abbinati. I numeri di chiamata possono avere una lunghezza max. di 22 cifre, i nomi di max. 10 lettere.

- Assegnare a tutti i numeri di chiamata sempre un prefisso in modo da poter riconoscere anche una chiamata urbana in arrivo ed abbinarla ad una voce presente nella rubrica telefonica.
- Con capacità di memoria esaurita, sul display compare l'indicazione **PIENA** dopo aver memorizzato l'ultimo messaggio. Per poter disporre di nuovo spazio memoria, cancellare prima una voce già presente.
- Le voci della rubrica telefonica sono elencate in ordine alfabetico. Per accedere direttamente alla voce della rubrica telefonica desiderata, premere la lettera iniziale corrispondente.
- Non premendo con rubrica aperta alcun tasto per 30 secondi, il telefono passa di nuovo alla modalità di stand-by.

Inserire nomi

I nomi possono avere una lunghezza max. di 10 lettere.

I tasti numerici riportano anche delle lettere. Premendo ripetutamente il relativo tasto si ha modo di selezionare lettere, cifre e caratteri speciali.



Per immettere la stessa lettera una seconda volta, premere la rispettiva lettera. Attendere finché il cursore si sposta di una posizione. Immettere quindi la lettera una seconda volta.



Immettere spazi vuoti



Cancellare segni

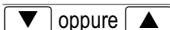

Cambiare la posizione del cursore (segno lampeggiante)



In un testo è sempre possibile immettere nuovi segni davanti alla posizione del cursore.

Creare voci di rubrica



Aprire il menu principale

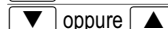

Selezionare la funzione e confermare

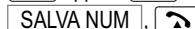

Immettere il numero di chiamata (max. 22 cifre) e confermare

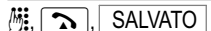

Immettere il nome (max. 10 lettere) e confermare

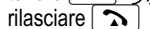

Registrare il nome



Una registrazione può avere una lunghezza max. di 4 secondi. Dopo di ciò la registrazione è interrotta automaticamente.

Alla fine della registrazione, il nome registrato è riprodotto.



La registrazione di un nome è opzionale e può essere eseguita anche in un secondo momento. Vantaggio di un nome registrato: in caso il numero chiami, tra i primi due squilli il telefono riproduce 2 volte il nome registrato. In questo modo si evita di doversi avvicinare al telefono per vedere chi chiama.

Modificare voci in rubrica



Aprire la rubrica

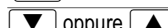

Selezionare la voce in rubrica

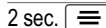

Avviare la modifica



Modificare il numero telefonico e confermare



Modificare il nome e confermare

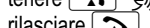





Registrare il nome





Rubrica telefonica

Cancellare voci in rubrica

Cancellare una voce

	Aprire la rubrica
 oppure 	Selezionare la voce in rubrica
 CANCELLA?	Attivare la cancellazione
2 sec. 	Confermare la cancellazione

Cancellare tutte le voci

	Aprire la rubrica
 oppure 	Selezionare la voce in rubrica
2 sec.  CANC.TUTT?	Attivare la cancellazione
2 sec. 	Confermare la cancellazione









Riproduzione audio delle voci in rubrica

Una volta memorizzato un numero telefonico in rubrica, alla voce in rubrica può essere abbinata la registrazione di un nome. Non appena si seleziona una voce in rubrica, il telefono riproduce il nome registrato e in questo modo si viene informati sulla voce selezionata.



I nomi possono essere registrati subito in sede di creazione di una voce in rubrica, oppure in seguito. Lo stesso vale per voci già presenti in rubrica.











Registrare un nome

	Aprire il menu principale
 oppure 	Selezionare la funzione
RECORD NOM , 	e confermare
 oppure 	Selezionare la voce di rubrica
tenere 	Avviare la registrazione
rilasciare 	Concludere la registrazione



Se non si rilascia il tasto, la registrazione si conclude automaticamente dopo 4 secondi.

Cancellare la registrazione

	Aprire la rubrica
 oppure 	Selezionare la voce in rubrica
2 sec. 	Avviare la modifica
 , 	Se occorre, modificare il numero telefonico e confermare
 , 	Se occorre, modificare il nome e confermare
RECORD NOM tenere 	
«lungo tono di segnale» rilasciare 	Effettuare la cancellazione

10 Lista chiamate/ripetizione di chiamata

Gli ultimi 15 numeri telefonici di chiamate in arrivo e gli ultimi 15 numeri telefonici selezionati sono visualizzati in una lista chiamate/ripetizione di chiamata combinata (qui di seguito indicata come "lista").

Nuove chiamate

In presenza di nuove chiamate in lista, sul display compare il simbolo del telefono .

Avendo selezionato nel menu LED CHIA.N:ON, il LED di chiamata/chiamata d'emergenza lampeggiante in rosso indica che nella lista risultano memorizzate nuove chiamate. Non appena le voci risultano essere state visualizzate, il LED di chiamata/chiamata d'emergenza si spegne.

 Menu pag. 60

Visualizzare numeri telefonici in lista



Aprire la lista



La voce più recente è visualizzata per prima.

oppure



Aprire la lista e visualizzare la voce più recente

oppure



Aprire la lista e visualizzare la voce più remota



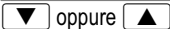

Selezionare la voce successiva a quella più recente e visualizzare

oppure



Selezionare la voce e visualizzare

- Se si tratta di telefonate riferite alla giornata in corso, il telefono visualizza anche il rispettivo orario. Se la voce è più remota viene visualizzata la data.
- Se si tratta di un numero telefonico selezionato, sul display compare il simbolo di ripetizione di chiamata .
- Se si tratta di una chiamata ricevuta, sul display compare il simbolo CID (inglese per **C**aller **I**dentification).

- Se si tratta di numeri di nuove chiamate ricevute e non ancora visualizzati, sul display compare il simbolo del telefono .

Messaggi di display

Display	Descrizione
NO NUMERO	Indica una chiamata internazionale o una chiamata effettuata da un apparecchio interno.
PRIVATO	Il chiamante ha soppresso l'inoltro del proprio numero telefonico oppure si tratta di una chiamata effettuata da un apparecchio interno.

Richiamare un numero dalla lista

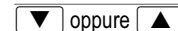

Aprire la lista e selezionare una voce



Selezionare un numero di chiamata

oppure

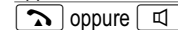

Selezionare un numero di chiamata (funzione vivavoce)

Salvare in rubrica un numero della lista

Un numero telefonico può essere salvato direttamente dalla lista in rubrica.

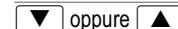

Aprire la lista e selezionare una voce

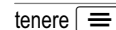

Avviare la memorizzazione



Se occorre, modificare il numero telefonico (max. 22 cifre) e confermare

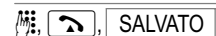

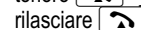
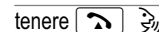

Immettere il nome (max. 10 cifre) e confermare



Registrare il nome

Lista chiamate/ripetizione di chiamata

 Una registrazione può avere una lunghezza max. di 4 secondi. Dopo di ciò la registrazione è interrotta automaticamente.

 Avendo abbinato in rubrica ad un numero telefonico anche un nome, nella lista compare in più il nome definito.

Cancellare numeri telefonici dalla lista

Cancellare singoli numeri telefonici

oppure Aprire la lista e selezionare una voce

Attivare la cancellazione

tenere Confermare la cancellazione

oppure

oppure Interrompere la cancellazione

Cancellare tutti i numeri telefonici

 Controllare prima di cancellare numeri telefonici se le voci interessate sono state visualizzate.

oppure Aprire la lista e selezionare una voce

2 sec. Attivare la cancellazione

tenere Confermare la cancellazione

oppure

oppure Interrompere la cancellazione

11 In presenza di problemi

Linea di assistenza

In presenza di problemi con il telefono, seguire le indicazioni riportate qui di seguito. In caso di problemi tecnici è possibile rivolgersi alla nostra linea di assistenza tecnica chiamando al numero 0900 00 1675 valido per la Svizzera (spese da rete Swisscom alla data di stampa: 2,60 CHF/min). In caso di reclami entro il periodo di garanzia, rivolgersi al rivenditore autorizzato. Il periodo di garanzia ricopre 2 anni.

Domande e risposte

Domande	Risposte
Non è possibile condurre una chiamata telefonica	<ul style="list-style-type: none"> - La linea telefonica non è collegata correttamente oppure presenta un guasto. Utilizzare esclusivamente il cavo di collegamento telefonico fornito. - L'alimentatore di rete non è inserito oppure si è in presenza di una caduta di tensione totale.
Alcune funzioni, ad es. l'amplificazione a +40 dB o il dispositivo vivavoce non funzionano	<ul style="list-style-type: none"> - Controllare se le pile sono inserite correttamente, se il tipo di pile utilizzato è idoneo e se sono cariche.

La visualizzazione del numero di chiamata (CLIP¹) non funziona

- La visualizzazione del numero di chiamata è un servizio opzionale offerto dal proprio gestore di rete telefonica. Per maggiori dettagli rivolgersi al proprio gestore di rete telefonica.
- Il chiamante ha disattivato la trasmissione del proprio numero di chiamata.

Non è possibile lanciare una chiamata d'emergenza. Al suo posto si avverte una duplice segnalazione acustica.

- Nel menu CHIAM.EMER risulta attivato OFF.
- Sui tasti d'emergenza non risulta memorizzato alcun numero telefonico.
- L'alimentatore di rete del telefono non è collegato correttamente.
- Le 4 pile del telefono non sono cariche.
- La pila del dispositivo di telesoccorso non è carica.

¹ **CLIP: Calling Line Identification Presentation** = Visualizzazione del numero telefonico del chiamante.

Consigli per la cura / Garanzia

12 Consigli per la cura / Garanzia

Consigli per la cura

- Pulire le superfici degli apparecchi con un panno morbido e antipelucchi.
- Non utilizzare mai detergenti o solventi.

Garanzia

Gli apparecchi SWITEL sono costruiti e collaudati in osservanza dei processi di produzione più moderni. L'impiego di materiali selezionati e tecnologie altamente sviluppate sono garanti di una perfetta funzionalità e lunga durata in vita. La garanzia non viene considerata esecutiva qualora la causa del malfunzionamento dell'apparecchio sia riconducibile al gestore della rete telefonica oppure se questa è da attribuirsi ad un impianto telefonico interno interposto. La garanzia non si estende a pile, batterie ricaricabili o pacchi batteria utilizzati all'interno degli apparecchi. Il periodo di garanzia ricopre 24 mesi a partire dalla data di acquisto.

Entro il periodo di garanzia si procederà all'eliminazione gratuita di tutti i guasti dovuti a difetti di materiale o produzione. Il diritto di garanzia cessa in caso di interventi da parte dell'acquirente o di terzi. Danni derivanti da un impiego o esercizio non conforme agli usi previsti, a naturale usura, a errato montaggio o errata conservazione, a collegamento o installazione impropri, dovuti a forza maggiore o ad altri influssi esterni non sono coperti da garanzia. In qualità di produttore ci riserviamo il diritto, in caso di reclami, di riparare o sostituire le parti difettose o di rimpiazzare l'apparecchio. Parti o apparecchi sostituiti passano di nostra proprietà. Sono esclusi diritti di risarcimento per danni qualora non siano dovuti a intenzione o colpa grave del costruttore.

Nel caso in cui il presente apparecchio dovesse ciò nonostante presentare un difetto durante il periodo di garanzia, si prega di rivolgersi esclusivamente al negozio di rivendita dell'apparecchio SWITEL assieme al relativo scontrino di acquisto. In base alle presenti disposizioni, tutti i diritti di garanzia dovranno essere fatti valere esclusivamente nei confronti del rivenditore autorizzato. Decorso il termine di due anni dalla data di acquisto e consegna dei nostri prodotti non sarà più possibile fare valere alcun diritto di garanzia.

Dichiarazione di conformità

Questo apparecchio risponde a quanto disposto dalla Direttiva UE 1999/5/CE concernente le apparecchiature radio, le apparecchiature terminali di telecomunicazioni e il reciproco riconoscimento della loro conformità. La conformità con la direttiva indicata è confermata dal marchio CE applicato sull'apparecchio.



Per la dichiarazione di conformità completa si prega di voler usufruire del servizio gratuito di download dal nostro sito Internet www.switel.com.

13 Indice alfabetico

A

Alimentatore di rete, 48
 Altoparlante, 51
 Annullare la registrazione del dispositivo di telesoccorso sul telefono, 58
 Attivare/Disattivare il tono dei tasti, 60
 Aumentare il volume del ricevitore, 53
 Avviare una chiamata d'emergenza automatica, 57

C

Cancellare, 62
 Cancellare il messaggio d'emergenza, 58
 Cancellare la registrazione, 62
 Cancellare numeri telefonici dalla lista, 64
 Chiamata d'emergenza automatica, 56
 Chiamata d'emergenza automatica tramite dispositivo di telesoccorso, 57
 Chiamata d'emergenza automatica tramite telefono, 57
 Come funziona il mio telefono?, 52
 Compatibilità con protesi acustiche, 48
 Compiere telefonate, 53
 Concludere la chiamata, 53
 Concludere la chiamata d'emergenza automatica da parte del rispettivo destinatario, 57
 Concludere la chiamata d'emergenza automatica da parte del rispettivo mittente, 57
 Conclusione automatica della chiamata d'emergenza, 57
 Consigli per la cura, 66
 Controllare la pila del dispositivo di telesoccorso, 58
 Creare, 61

D

Data, 50
 DC, 60
 Dichiarazione di conformità, 66
 Disattivare la chiamata d'emergenza automatica, 60
 Display, 51
 Domande e risposte, 65
 Durata di conversazione, 53

E

Elementi di comando, 51
 Eliminare i guasti, 65

F

Funzione vivavoce, 55

G

Garanzia, 66

I

Immissione di testi, 61
 Impianti telefonici interni, 59
 Impostare data e ora, 60
 Impostare il contrasto, 60
 Impostare il contrasto di display, 60
 Impostare il tempo flash, 59, 60
 Impostare il volume del ricevitore, 53
 Impostare il volume di squillo, 53, 60
 Impostare la lingua, 60
 Impostare la suoneria, 60
 Indicazioni di sicurezza, 48
 Inserimento delle pile, 50
 Inserire nomi, 61

L

LED amplificatore, 51
 LED capacità delle , 51
 LED di chiamata/chiamata d'emergenza, 51, 63
 LED vivavoce, 51
 Linea di assistenza, 65
 Lista chiamate/ripetizione di chiamata, 63
 Luogo di installazione, 48

M

Menu principale, 60
 Messa in funzione, 49
 Messaggi di display, 63
 Messaggio d'emergenza, 56, 57
 MF, 60
 Microfono, 51
 Modi di scrittura, 52
 Modificare, 61
 Montaggio a parete, 50

N

Navigare nel menu, 52

O

Oggetto di fornitura, 49
 Ora, 50

P

Pausa di selezione, 59
 Problemi, 65
 Procedura di selezione a impulsi, 60
 Procedura di selezione a toni, 60
 Procedura di selezione multifrequenza, 60
 Programmare i tasti d'emergenza, 54
 Programmare i tasti di selezione diretta, 54
 Programmare i tasti di servizio, 55

R

Rappresentazioni, 52
 Registrare il dispositivo di telesoccorso sul telefono, 58
 Registrare il messaggio d'emergenza, 58
 Registrare un nome, 62
 Regolazione del suono, 51, 53
 Ricevere una chiamata, 53
 Ricevitore, 51
 Richiamare un numero dalla lista, 63
 Richiamata di chiamate perse, 54
 Ripetizione di chiamata, 54
 Riprodurre il messaggio d'emergenza, 57, 60
 Riproduzione audio delle voci in rubrica, 62
 Rubrica telefonica, 61

Indice alfabetico

S

Salvare, 61
Salvare in rubrica un numero della lista, 63
Scopo d'impiego, 48
Segnale d'emergenza, 56
Selettore per regolazione del suono, 51
Selettore per volume del ricevitore, 51
Selezionare la suoneria, 60
Selezionare numeri dalla rubrica , 54
Selezione diretta, 54
Servizi addizionali, 59
Servizi d'emergenza domestica, 56
Simboli sul display, 52
Smaltimento, 48
Sostituire la pila del dispositivo di telesoccorso, 58
Struttura di menu, 60

T

Tasti d'emergenza, 51, 54
Tasti di selezione diretta, 51
Tasti di servizio, 51, 55
Tasti numerici, 51
Tasto amplificatore (+40 dB), 51
Tasto asterisco, 51
Tasto Cancella/Indietro, 51
Tasto cancelletto, 51
Tasto d'emergenza, 51
Tasto di chiamata/OK, 51
Tasto di menu, 51
Tasto giù, 51
Tasto R, 51
Tasto R e servizi addizionali, 59
Tasto R in impianti telefonici interni, 59
Tasto rubrica , 51
Tasto su, 51
Tasto vivavoce, 51
Telefonare con i tasti d'emergenza, 54
Telefonare con i tasti di selezione diretta, 54
Telefonare con i tasti di servizio, 55

U

Unità base, 49

V

Visualizzare numeri telefonici in lista, 63
Visualizzazione del numero di chiamata, 59
Visualizzazione di nuove chiamate, 63
Voci di rubrica, 61
Volume del dispositivo vivavoce, 55

1	Safety Information	70
2	Preparing the Telephone	71
3	Operating Elements	73
4	Operating the Telephone	74
5	Telephoning	75
6	Automatic Emergency Call (SOS)	78
7	PBX / Supplementary Services	81
8	Menu Structure	82
9	Phone Book	83
10	Calls Missed and Redialling List	85
11	In Case of Problems	87
12	Maintenance / Guarantee	88
13	Index	89

Safety Information

1 Safety Information

Please read this operating instruction manual thoroughly.

Intended use

The telephone is suitable for telephoning within a public telephone network system. Any other use is considered unintended use. Unauthorised modification or reconstruction is not permitted. Under no circumstances open the equipment or complete any repair work yourself.

Installation location

Prevent excessive exposure to smoke, dust, vibration, chemicals, moisture, heat and direct sunlight.

Power adapter plug



Attention: Only use the power adapter plug supplied because other power supplies could damage the telephone. Ensure access to the power adapter plug is not obstructed by furniture or such.

Hearing aid compatibility

Using the premium receiver, the telephone is perfectly adapted for hearing aids and is compatible with most commercially available hearing aids. However, due to the wide range of hearing aids available, there is no guarantee that the telephone will function problem-free with every model.



Attention: This phone is capable of providing extremely loud volumes when the amplification is activated and the volume control is set to maximum. The utmost caution is necessary when the phone is used jointly by people with normal hearing and others with impaired hearing.

Disposal

In order to dispose of your device, take it to a collection point provided by your local public waste authorities (e.g. recycling centre). According to laws on the disposal of electronic and electrical devices, owners are obliged to dispose of old **electronic and electrical devices** in a separate waste container. The symbol indicates that the device must not be disposed of in normal domestic waste!



Risks to health and the environment from batteries!

Never open, damage or swallow batteries or allow them to pollute the environment. They could contain toxic and ecologically harmful heavy metals. You are legally obliged to dispose of power packs and batteries at the point of sale or in the corresponding containers provided at collection points by local public waste authorities. Disposal is free of charge. The above symbols indicate that the batteries must not be disposed of in domestic waste and that they must be disposed of at an authorised collection point.

Packaging materials must be disposed of according to local regulations.

2 Preparing the Telephone

Safety information



Attention: It is essential to read the Safety Information in Chapter 1 before starting up.

Checking the package contents

The package contains:

Content	TF 520
Base unit	1
Power adapter plug	1
Receiver	1
Helix cable for receiver	1
Emergency call unit with wrist strap and neckband (splashproof)	1
Telephone connection cable	1
Batteries, type AA 6 V	4
Battery, type A23 12 V (installed in emergency call unit)	1
Wall installation bracket	1
Operating manual	1

Important note

Your device is supplied with an energy-efficient switching power supply (Input 230 V_{AC}, Output 9 V_{DC}, 300 mA). The adaptor input power without load is approx. 0.1 W. The average efficiency is > 68.46 %. The electrical consumption is max. 3.91 W.

Connecting the base unit

Connect the telephone as illustrated in the diagram. For reasons of safety, only use the power adapter plug and telephone connection cable supplied.

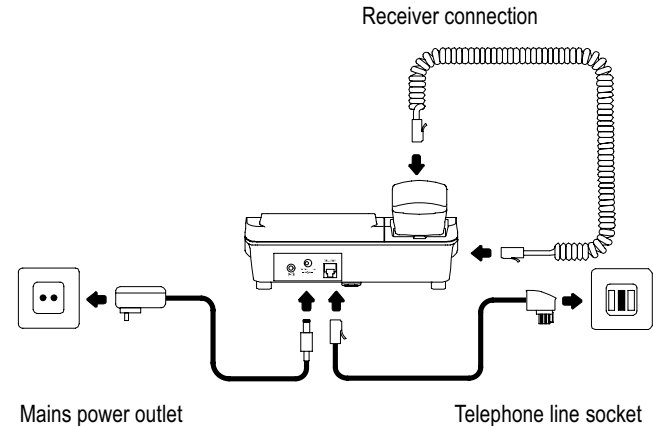

The telephone can be operated with or without the power adapter plug. If you want to operate the telephone without the power adapter plug, ensure that sufficiently charged batteries of the correct type are properly installed.

Preparing the Telephone

Inserting the batteries

 Pay attention that the telephone is not connected to the telephone line socket and/or mains power socket when the batteries are being inserted or replaced.

Insert the batteries in the open battery compartment. Only use batteries of the type AA 6 V. Pay attention to the correct polarity. Close the battery compartment cover.

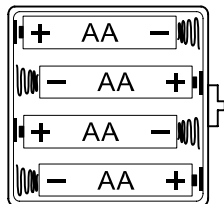

 Insertion of batteries is not absolutely essential. The telephone can be operated with or without batteries. If you want to operate the telephone without batteries, the power adapter plug must be connected.

 **Attention:** If you operate the telephone without batteries, it is not possible to make a call or an emergency call in the event of a power failure!

If the batteries are no longer fully charged or are empty, the battery icon  appears in the display. Replace the batteries.

Setting the time and date

 Menu Structure, Page 82

Diverse settings

Various settings for the telephone can be defined using the menu, e.g. dialling mode (TONE/PULSE), ringing tone (RING MEL), key tone (KEY-TONE), display contrast (CONTRAST), announcement of key pressed (VOICE), illumination of LEDs and much more;  Menu Structure, Page 82.

Private branch exchanges

The information on Page 81 explains how to install your telephone in a private branch exchange.

Wall installation

Feed the guide tabs (1) on the wall-mounting bracket (2) in the slots (3) on the rear side of the telephone. Slide the wall bracket (2) 10 mm upwards until it audibly snaps into place. Drill a hole in the wall and insert a screw leaving about 5 mm of the screw projecting from the wall. Guide the mounting hole (4) in the wall mounting bracket (2) over the screw and slide the telephone downwards.

 **Attention:** Ensure there are no cables in the wall at the point where the hole is drilled.

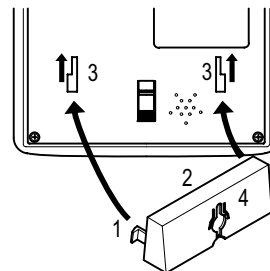

Turn the hook (5) in the receiver cradle so that the receiver can be placed on-hook.

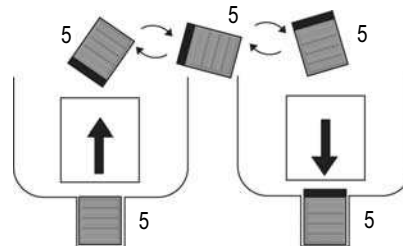

3 Operating Elements

Telephone

- | | |
|---|---|
| 1 Receiver volume slide control | 13 Menu button |
| 2 Loudspeaker (for handsfree function) | 14 R-button |
| 3 Receiver | 15 Missed calls and redialling button |
| 4 Phone book button | 16 Amplifier LED |
| 5 Delete/Back button | 17 Amplifier button (+40 dB) |
| 6 Call/OK button | 18 Handsfree button |
| 7 Scroll down button / Lower handsfree volume | 19 Handsfree LED |
| 8 Scroll up button / Raise handsfree volume | 20 Microphone |
| 9 Display | 21 Digit keys (including Star and Hash buttons) |
| 10 Call/SOS LED | 22 Service buttons |
| 11 Large red SOS call buttons (3 pieces) | 23 Tone slide control |
| 12 One-touch dialling buttons (5 pieces) | |

Emergency call unit

- | |
|--------------------------------|
| 24 SOS call button |
| 25 Battery charge capacity LED |

The buttons in this operating manual are depicted with a uniform contour. Variations in the symbols on the telephone buttons compared to those depicted here are possible.

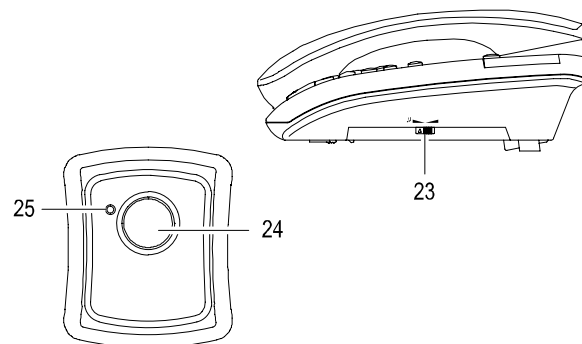
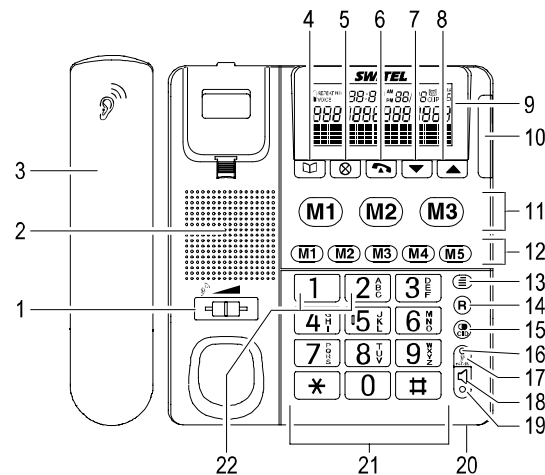

Operating the Telephone

4 Operating the Telephone

Display and explanation of operation sequences

	Enter the digits or letters
	Press the button depicted briefly
2 x	Press the button depicted twice, briefly
2 sec.	Press the button depicted for 2 sec.
Hold	Press and hold the button depicted
Release	Release the button depicted
	Phone rings
	Pick up the receiver
	Replace the receiver on-hook
	Speak your text
	Text flashes in the display
LANGUAGE or	Text or icons in the display

Icons in the display

The display lights up when a button is pressed and for a short time after.

Icon	Description
	The battery icon appears in the display if there are no batteries in the base unit and when the batteries installed are no longer full or are empty. Insert fully charged batteries; Page 72 .
	The icon with the crossed-out bell appears in the display when the ringing volume has been switched off (level 0, muted); Page 75 .
	The handsfree icon appears in the display when the handsfree function has been activated; Page 77
	The telephone icon appears in the display when new entries have been recorded in the missed calls and redialling list; Page 85

Icon	Description
	The SOS icon appears in the display as soon as an automatic emergency call (SOS) has been initiated and has not yet ended; Page 78 .
CID	The CID icon appears in the display when phone numbers in the missed calls and redialling list are viewed which were previously called; Page 85
	The redialling icon appears in the display when phone numbers in the missed calls and redialling list are viewed which were previously dialed; Page 85
	The amplifier icon appears in the display when the amplifier for the receiver volume has been permanently set to +40 dB via the menu; Page 75

Navigating in the menu

All the functions can be accessed via the various menus. Refer to the Menu Structure [Page 82](#) for information on how to access each respective function.



	Open the main menu
	Select the submenu required
	Open the submenu
	Select the setting required
	Use the digit keys to enter numbers or letters
	Confirm the entries
	Cancel the programming and saving processes and return to Standby mode

Every process is automatically cancelled if there is no input within 15 seconds.

5 Telephoning

Taking a call



If a call is received, the Call/SOS LED flashes.



 The flashing of the Call/SOS LED can be altered;  Menu Structure, Page 82 (RING LIGHT).

,  or  Take the call

or

 Take the call (handsfree function)

 If the caller number display (CLIP) is available on your telephone line ( Page 81) and you have selected VOICE:ON via the menu, the phone number of the caller is announced prior to the ringing tone.

 If the phone number of a caller has been stored in the phone book ( Page 83) and a name vocally recorded for it, the name recorded is announced between the first two rings.

Displaying the duration of a call

The duration of a call is displayed in minutes and seconds during the call.

Ending a call

 or  End the call

or (if the handsfree function is active)

 End the call

Making a call

 Enter the phone number (max. 22 digits)

 Delete the last digit if incorrect

 Dial the phone number

or

 or  Dial the phone number (handsfree function)

 It is also possible to pick up the receiver first to obtain the dialling tone. The digits then entered are dialled immediately. It is not possible to correct wrong digits individually using this dialling procedure.

Setting the ringing volume

The ringing volume can be altered to one of 5 different volume levels using the menu;  Page 82:

- Level 0: Ringing volume off (mute)
- Level 1: Ringing volume quiet
- Level 4: Ringing volume loud

Setting the receiver volume

Adjust the receiver volume using the slide control which is located underneath the receiver when on the base unit:

- Slide control to the left: Receiver volume becomes quieter.
- Slide control to the right: Receiver volume becomes louder.

Amplifying the receiver volume to +40 dB

The receiver volume can be increased to +40 dB by pressing the Amplification button.

 Amplification on

 Amplification off

You can use the menu to set-up the telephone so that the amplification is set to +40 dB directly without the need to press the Amplification button. Open the menu and select BOOST LOCK:ON;  Menu Structure, Page 82.

Receiver tone control

 The tone control only works when the receiver volume amplification to +40 dB has been activated (amplification LED lights up).

You can adjust the tone produced in the receiver using a slide control on the right-hand side of the housing.

Telephoning

Redialling and calling back missed calls

The telephone stores the last 15 phone numbers in a calls missed and redialling list; Page 85.

	Open the list
or	Select the required phone number
	Dial the phone number

- In the case of numbers dialled, the redialling icon appears in the display.
- In the case of missed calls, the CID icon **CID** appears in the display (Caller Identification).

Dialling phone numbers from the phone book

Phone numbers must have been stored in the phone book for this function; Page 83.

	Open the phone book
or	Select the entry required
	Dial the number

One-touch dialling buttons

The telephone is provided with 5 one-touch dialling buttons (M1 to M5) (M = Memory) which you can use to dial frequently required numbers.

Programming one-touch dialling buttons

	Enter the phone number (max. 22 digits)
--	--

Press and hold , , , or	Assign the phone number to a one-touch dialling button
----------------------------	---

Phone numbers assigned cannot be deleted, they can only be overwritten by new phone numbers.

Dialling using one-touch dialling buttons

, , , or	Press the required one-touch dialling button
or	Dial the number

SOS (emergency call) buttons

The telephone is provided with 3 large red SOS buttons which can be used to dial important phone numbers quickly and easily.

Programming SOS buttons

Please note that the phone numbers which are assigned to the 3 SOS buttons are called in succession in the event of an automatic SOS call, beginning with M1; Page 78.

	Enter the phone number (max. 22 digits)
--	--

Press and hold , , or	Assign the phone number to the SOS button
--------------------------	--

Phone numbers assigned cannot be deleted, they can only be overwritten by new phone numbers.
In order to change the cursor position in an existing entry, press the Scroll Up and Scroll Down buttons. To delete characters, press the Delete/Back button.











Dialling using the SOS buttons

, or	Press the required SOS button
or	Dial the number

Service buttons

You can program special service numbers for the **1** and **2^{ABC}** buttons and then call these numbers quickly and easily using the corresponding buttons.



Programming service buttons

	Open the main menu
 or 	Select the function and confirm it
SERVICES, 	
KEY 1,2,  or 	Select key 1 or 2 (the digit on the key selected flashes) and confirm it
	
 	Enter the phone number (max. 22 digits) and confirm it
  , SAVED	Enter the name (max. 10 characters) and confirm it



Phone numbers programmed cannot be deleted, they can only be overwritten by new phone numbers. In order to change the cursor position in an existing entry, press the Scroll Up and Scroll Down buttons. To delete characters, press the Delete/Back button.

Dialling using the service buttons

Press and hold 1 or 2^{ABC}	Press the required service button until the phone number is displayed
 or 	Dial the number

Handsfree function

Use the handsfree function in order to listen to callers via the loudspeaker and talk to them without having to hold the receiver to your ear.

	Activate the handsfree function during a call
---	---

When the handsfree function is activated, the handsfree LED lights up red. Speak towards the microphone. The microphone is at the front right of the base unit.

	Deactivate the handsfree function during a call
---	---



You can switch between handsfree and conventional use with the receiver as often as necessary. Important: The receiver must be removed from the base unit!



Background noise, e.g. loud music, can interfere with the hands-free call quality.

Adjusting the volume for the handsfree feature

You can adjust the handsfree volume to one of 8 levels using the Scroll Up and Scroll Down buttons (quiet = level 1 to loud = level 8).

	Lower the handsfree volume
	Raise the handsfree volume

Automatic Emergency Call (SOS)

6 Automatic Emergency Call (SOS)



An automatic SOS call can only be made when ALARM FUNC:ON is activated in the menu; Menu Structure, Page 82, the telephone is operated via the power adapter plug or when 4 charged batteries are installed in the telephone and 1 charged battery is installed in the emergency call unit.

The emergency call unit can be used to dial an emergency services exchange or specific persons for assistance.



There are several emergency services exchanges available. In some countries, these may be subject to a charge. You can also use the equipment as a private emergency call device within the family.

How the automatic SOS call works

The telephone reacts as follows after starting an automatic SOS call:

- A loud SOS signal sounds for 15 seconds on the base unit. The Call/SOS LED flashes at the same time.



If you have activated QUIET AL.:ON in the menu, the SOS alarm signal is not played. Only the Call/SOS LED flashes.

- The handsfree function is switched on.
- The numbers assigned to the 3 SOS call buttons are dialed in succession:
- The first number dialed is that assigned to the large red **(M1)** button.
- It rings for maximally 60 seconds. If the call is not taken within this time, the call is ended.
- The SOS alarm signal sounds again on the base unit for 15 seconds.
- The number assigned to the large red **(M2)** button is then dialed for 60 seconds.
- If this call is not taken within the specified time, the same procedure is repeated as before; the alarm signal is sounded for 15 seconds and then the phone number assigned the large red **(M3)** button is dialed.



If no phone numbers have been assigned to the three large red buttons **(M1)**, **(M2)** or **(M3)**, no phone number is dialed but the SOS alarm signal sounds.

- As soon as one of the SOS calls is taken, the person taking the call hears the outgoing alert message in a continuous cycle.



When the telephone leaves the factory, the following outgoing alert message is already recorded: "This is an emergency call, to accept this call, press zero." However, you can record your own outgoing alert message; Page 79.

- When the person receiving the SOS call presses the [0] button on their phone, this ends the outgoing alert message and a connection to the SOS caller is automatically established. The person making the SOS call automatically uses the handsfree function.



If the SOS call is not taken by anyone, the telephone then repeats the cycle and calls the phone numbers assigned to the large red SOS buttons **(M1)**, **(M2)** and **(M3)** in the same sequence. The telephone completes a maximum of 4 complete cycles which takes approx. 15 minutes. If the call is not taken, the automatic SOS call is automatically stopped.

Assigning phone numbers to the SOS buttons

Page 76

Starting SOS calls



In order to call for assistance, correctly functioning phone numbers must be programmed and assigned to the SOS buttons.

Automatic SOS call via the emergency call unit



Pay attention that there is always a fully charged battery in the emergency call unit, the emergency call unit is registered on the telephone and it is within range of the telephone!

Press and hold the SOS button on the emergency call unit for at least 1 second.



While the SOS button is being pressed, the battery charge capacity LED lights up.

Automatic SOS call via the telephone

Hold **(M1)**, **(M2)** or **(M3)** Start the automatic SOS call process

Ending the automatic SOS call by the SOS call sender

3 sec. End automatic SOS call

or

End automatic SOS call

or

End automatic SOS call

Ending the automatic SOS call by the SOS call recipient

Take the automatic SOS call

0 Take the automatic SOS call

Converse with the SOS caller

1 **2** End the automatic SOS call

Ending the automatic SOS call

The automatic SOS call ends automatically when none of the calls made to the 3 phone numbers assigned to the SOS buttons are answered.

Outgoing alert message

An outgoing alert message is already recorded on the telephone: "This is an emergency call, to accept this call, press zero.". You can replace this message with one of your own.

The outgoing alert message is repeated continuously until the person taking the call presses the [0] button on their phone. Therefore, be sure to end your own outgoing alert message with the sentence: "**Press the 0 button to take this SOS call**".



When recording your alert message, ensure the caller knows who is making the call. Ensure that your message clearly states that it is an emergency call and you require assistance.

Playing your outgoing alert message



Open the main menu

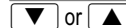

Select the required submenu

AL.MESSAGE



Play the outgoing alert message

Recording the outgoing alert message



The outgoing alert message may be a maximum of 30 seconds long.



Open the main menu

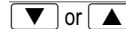

Select the required submenu

AL.MESSAGE



Start recording

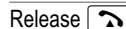

End recording

Deleting the outgoing alert message



Open the main menu

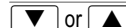

Select the required submenu

AL.MESSAGE

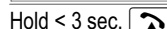











Hold < 3 sec. Complete the deleting process

Automatic Emergency Call (SOS)

Registering/Deregistering the emergency call unit on the telephone

Registering the emergency call unit on the telephone







 Up to 5 emergency call units can be registered on the telephone.

	Open the main menu
 or 	Select the required submenu and confirm it
PENDANT 	
 or 	Select the required submenu and confirm it
PAIRING  ...	
1 sec.  	Register the emergency call unit

 If the registration process proved unsuccessful, the message ERROR appears briefly in the display.



Deregistering the emergency call unit on the telephone

 It is only possible to deregister all the emergency call units in the process! Any emergency call units which are subsequently required must be registered on the telephone again!

	Open the main menu
 or 	Select the required submenu and confirm it
PENDANT 	
 or 	Select the required submenu and confirm it
DELETE? 	

Emergency call unit battery

Checking the battery

1. Press the SOS button  on the emergency call unit briefly. The battery charge capacity LED lights up while the button is pressed.
2. If the battery charge capacity LED no longer lights up on pressing the SOS button , replace the battery.

Changing the battery

1. Remove the 4 screws on the rear side of the emergency call unit using a crosstip screwdriver.
2. Open the cover of the battery compartment using a narrow screwdriver, for example.
3. Change the battery. Only use a battery of the type A23 12V. Pay attention to the correct polarity.
4. Close the cover of the battery compartment in the reverse sequence.

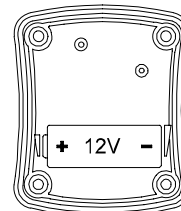

7 PBX / Supplementary Services

R button on private branch exchanges

If the telephone is connected to a private branch exchange, functions such as transferring calls and automatic call back can be used via the **R button**. Refer to the operating manual provided with your private branch exchange as to which Flash time must be set in order to use these functions. The sales outlet where you purchased the exchange can provide information as to whether the telephone will work properly with the exchange.

Setting the Flash time

 Menu Structure, Page 82

Dialling pause

When using private branch exchanges, it is necessary to dial an access code to obtain the dialling tone for an outside line. When using some older private branch exchanges, it takes a little time before the dialling tone becomes audible. In the case of such private branch exchanges, a dialling pause can be inserted after the number for an outside line in order to continue dialling directly without having to wait for the dialling tone.



Insert a dialling pause
"P" appears in the display

After dialling the number for the outside line, the telephone waits approx. 3 seconds before dialling the actual phone number.



The pause can also be entered with the phone number in the phone book.

R-button and supplementary services

Your telephone supports supplementary services provided by your telephone network provider, such as brokering, call waiting and conference facilities. These supplementary services can be used by implementing the **R button**. Please contact your telephone network provider regarding which Flash time must be set to use the supplementary services. Also contact your telephone network provider with regard to enabling supplementary services. Setting the Flash time;  Page 82.

Caller number display (CLIP¹)

If this function is available with your telephone line, the number of the caller appears in the display when the phone rings. If the phone number has been stored in the phone book, the name associated with it appears in the display.



If the name for a phone book entry has been spoken, the name recorded is played between the first two ringing tones. This means it is not necessary to go to the phone to see who is calling.

If the caller has suppressed transmission of their phone number, the corresponding message appears in the display. The phone number cannot be displayed and, as a result, is not stored in the missed calls and redialling list.



The caller number display function is an optional service offered by telephone network providers. Contact your network provider for further information.

¹ CLIP: Calling Line Identification Presentation







Menu Structure

8 Menu Structure

Main menu

Open the main menu by pressing the  button.

Confirm each entry by pressing the  button.

TIME/DATE	 /  to change the digits
SERVICES	KEY 1,2
	Use  /  to select digit 1 or 2 ¹
	 Enter number  Enter name
TONE/PULSE ²	TONE/PULSE
N CALL LED ³	ON/OFF
FLASH ⁴	100 / 300 / 600
KEYTONE	ON/OFF
CONTRAST	1 / 2 / 3 / 4
RING LIGHT ⁵	ON/OFF
AL.MESSAGE	Alert message is spoken
QUIET AL.	ON/OFF
ALARM FUNC	ON/OFF
BOOST LOCK	ON/OFF



¹ The digit selected flashes.

² Dual tone multi-frequency mode (DTMF) (tone dialling mode) and pulse dialling mode

³ Defines whether the Call/SOS LED should light up when new calls are recorded in the missed calls and redialling list.

⁴ In ms

⁵ When the phone rings, the Call/SOS LED flashes faster than usual.

RING VOL	0 / 1 / 2 / 3 / 4
RING MEL	1 / 2 / 3
VOICE ⁶	ON/OFF
PENDANT	PAIRING
	DELETE?
NAME REC	
STORE NO.	 Enter number  Enter name
LANGUAGE	DEUTSCH
	ENGLISH
	SVENSKA
	NEDERLANDS
	FRANCAIS
	ITALIANO

⁶ When a button is pressed, a voice accompanies the action. This voice can be activated and deactivated, as required.

9 Phone Book

You can use the phone book to store up to 99 phone numbers together with the associated names. Phone numbers may have a maximum of 22 digits and characters, names a maximum of 10 characters.





- Always enter the area access code with the phone numbers so that incoming local calls can also be assigned to a phone book entry.
- When the memory capacity is used up, the message **FULL** appears when an attempt is made to store another number. To create space, an existing entry must first be deleted.
- The phone book entries are arranged alphabetically. To access the required phone book entry directly, press the first letters of the corresponding name.
- If no button is pressed for 30 seconds while the phone book is open, the phone book is closed and the phone returns to Standby mode.

Entering names

Names may have a maximum of 10 characters.











Letters are also imprinted on the digit keys. Letters, digits and special characters are entered by pressing the relevant key the respective number of times.

 To enter the same letter twice, press the button to enter the letter. Wait until the cursor skips one position forwards. Enter the letter again.

	Enter a space
	Delete character
 or 	Change cursor position (character flashes)

 New characters can always be inserted in existing text in front of the cursor position.

Creating phone book entries











	Open the main menu
 or 	Select the required function and confirm it
STORE NO. , 	Enter the phone number (max. 22 digits) and confirm it
 , 	Enter the name (max. 10 characters) and confirm it
 , SAVED , 	Record the name
Hold   Release 	

 A recording may take a maximum of 4 seconds. Recording is then automatically stopped.

When recording has stopped, the name recorded is played back.

 Recording a name is an optional function and can also be completed separately, if necessary. Advantage of recording a name: When a call is received from this number, the name recorded is played twice between the first two rings. This means, it is not necessary to go to the phone to see who is calling.





Editing phone book entries

	Open the phone book
 or 	Select the phone book entry
2 sec. 	Initiate the editing process
 , 	Change the number and confirm it
 , 	Change the name and confirm it
Hold   Release 	Record the name





Phone Book

Deleting phone book entries

Deleting a single entry

	Open the phone book
 or 	Select the phone book entry
 DELETE?	Activate the deleting process
2 sec. 	Confirm the deleting process

Deleting all entries









	Open the phone book
 or 	Select a phone book entry
2 sec.  DEL ALL?	Activate the deleting process
2 sec. 	Confirm the deleting process

Voice output for phone book entries

A name can be recorded for each phone number stored in the phone book. When you subsequently select an entry in the phone book, the recording you made for it is played and you can hear the entry you have selected.











 Names can be recorded for phone book entries at the time they are created or later for existing phone book entries.

Recording a name

	Open the main menu
 or 	Select the required function
NAME REC 	and confirm it
 or 	Select the phone book entry
Hold 	Start recording
Release 	End recording

 If you do not release the button, recording is automatically stopped after 4 seconds.

Deleting a recording

	Open the phone book
 or 	Select the phone book entry
2 sec. 	Initiate the editing process
 	Change the number, if necessary, and confirm it
 	Change the name, if necessary, and confirm it
NAME REC Hold  (« longer acoustic signal»)	Complete the deleting process
Release 	

10 Calls Missed and Redialling List







The last 15 phone numbers of incoming calls and the last 15 phone numbers dialled are stored in a combined calls missed and redialling list (subsequently referred to simply as the "list").

New calls

If new calls have been recorded in the list, the phone icon  appears in the display.

If N CALL LED:ON is activated in the menu, the red, flashing Call/SOS LED indicates that new calls have been stored in the list. As soon as the entries have been viewed, the Call/SOS LED goes out.  Menu Structure, Page 82

Displaying phone numbers in the list

	Open the list
 The newest entry is at the top.	
or	
	Open the list and display the newest entry
or	
	Open the list and display the oldest entry
	Select the second oldest entry and view it
or	
 or 	Select the entry and view it





- In the case of entries received on that day, the time is also displayed. In the case of older entries, the date is displayed.
- In the case of numbers redialled, the redialling icon  appears in the display.

- In the case of missed calls, the CID icon CID appears in the display (**Caller Identification**).
- In the case of new missed calls, which have not previously been viewed, the telephone icon  appears in the display.

Messages in the display

Display	Description
NO NUMBER	This relates to an international call or a call from a private branch exchange.
PRIVATE	The caller has suppressed transmission of his/her phone number or the call has come from a private branch exchange.



Calling phone numbers in the list

 or 	Open the list and select an entry
	Dial the phone number
or	
 or 	Dial the phone number (handsfree function)

Calls Missed and Redialling List

Storing numbers from the list in the phone book

A phone number in the list can be stored in the phone book directly.

- or Open the list and select an entry
 - Hold Start the storing process
 - Edit the phone number if necessary (max. 22 digits) and confirm
 - , , Enter the name (max. 10 characters) and confirm it
 - Hold Record the name
 - Release
-  A recording may take a maximum of 4 seconds. Recording is then automatically stopped.
-  When the number in the phone book is stored together with a name, the name entered also appears in the list.

Deleting numbers from the list

Deleting individual phone numbers

- or Open the list and select an entry
- Activate the deleting process
- Hold Confirm the deleting process
- or
- or Cancel the deleting process

Deleting all phone numbers

-  Before deleting the phone numbers, check whether the entries have been viewed.
- or Open the list and select an entry
 - 2 sec. Activate the deleting process
 - Hold Confirm the deleting process
 - or
 - or Cancel the deleting process

11 In Case of Problems

Service hotline

Should problems arise with the telephone, please refer to the following information first. In the case of technical problems, you can contact our hotline service, Tel. 0900 00 1675 within Switzerland (Swisscom fees at time of going to print: CHF 2.60/min). In the case of claims under the terms of guarantee, contact your sales outlet. There is a 2 year period of guarantee.

Problems and solutions

Problems	Solutions
No telephone calls possible	<ul style="list-style-type: none"> - The telephone line is not connected properly or is defective. Only use the telephone connection cable supplied. - The power adapter plug is not plugged in or there is a complete power failure.
Some functions, e.g. +40 dB amplification or handsfree, do not work	<ul style="list-style-type: none"> - Check that the batteries are inserted correctly, are the correct type and they are not empty.

Caller numbers (CLIP¹) are not displayed

- The caller number display function is an optional service offered by telephone network providers. Contact your network provider for further information.
- The caller has suppressed the transmission of their phone number.

No automatic SOS call can be made. A double beep tone is issued instead.

- ALARM FUNC OFF is activated in the menu.
- No phone numbers have been programmed and assigned to the SOS buttons.
- The telephone's power adapter plug is not connected properly.
- 4 charged batteries have not been inserted in the telephone.
- No battery has been inserted in the emergency call unit.

¹ **CLIP: Calling Line Identification Presentation** = Displays the caller's phone number.

Maintenance / Guarantee

12 Maintenance / Guarantee

Maintenance

- Clean the housing surfaces with a soft, fluff-free cloth.
- Never use cleaning agents or solvents.

Guarantee

SWITEL equipment is produced and tested according to the latest production methods. The implementation of carefully chosen materials and highly developed technologies ensure trouble-free functioning and a long service life. The terms of guarantee do not apply where the cause of equipment malfunction is the fault of the telephone network operator or any interposed private branch extension system. The terms of guarantee do not apply to the batteries or power packs used in the products. The period of guarantee is 24 months from the date of purchase.

All deficiencies related to material or manufacturing errors within the period of guarantee will be redressed free of charge. Rights to claims under the terms of guarantee are annulled following tampering by the purchaser or third parties. Damage caused as the result of improper handling or operation, normal wear and tear, incorrect positioning or storage, improper connection or installation or Acts of God and other external influences are excluded from the terms of guarantee. In the case of complaints, we reserve the right to repair defective parts, replace them or replace the entire device. Replaced parts or devices become our property. Rights to compensation in the case of damage are excluded where there is no evidence of intent or gross negligence by the manufacturer.

If your device does show signs of a defect within the period of guarantee, please contact the sales outlet where you purchased the SWITEL device, producing the purchase receipt as evidence. All claims under the terms of guarantee in accordance with this agreement can only be asserted at the sales outlet. No claims under the terms of guarantee can be asserted after a period of two years from the date of purchase and hand-over of the product.

Declaration of Conformity

This device fulfils the requirements stipulated in the EU directive:

1999/5/EC directive on radio equipment and telecommunications terminal equipment and the mutual recognition of their conformity. Conformity with the above mentioned directive is confirmed by the CE mark on the device.



To view the complete Declaration of Conformity, please refer to the free download available on our web site at

www.switel.com.

13 Index

A

Amplifier button (+40 dB), 73
 Amplifier LED, 73
 Amplifying the receiver volume, 75
 Automatic emergency call (SOS), 78
 Automatic SOS call, 78
 Automatic SOS call via the emergency call unit, 79
 Automatic SOS call via the telephone, 79

B

Base unit, 71
 Battery charge capacity LED, 73

C

Call/Emergency call LED, 73
 Call/OK button, 73
 Call/SOS call LED, 85
 Caller number display (CLIP), 81
 Calling back missed calls, 76
 Calling phone numbers in the list, 85
 Calls missed and redialling list, 85
 Changing the emergency call unit battery, 80
 Checking the emergency call unit battery, 80
 Creating, 83

D

Date, 72
 Deactivate the automatic SOS call, 82
 Declaration of Conformity, 88
 Delete/Back button, 73
 Deleting, 84
 Deleting a recording, 84
 Deleting numbers from the list, 86
 Deleting the outgoing alert message, 79
 Deregistering the emergency call unit on the telephone, 80
 Dialling pause, 81
 Dialling phone numbers from the phone book, 76
 Dialling using one-touch dialling buttons, 76
 Dialling using the service buttons, 77
 Dialling using the SOS buttons, 76
 Digit keys, 73
 Display, 73, 74
 Display messages, 85
 Displaying phone numbers in the list, 85
 Disposal, 70
 DTMF, 82
 Dual tone multi-frequency mode, 82

E

Editing, 83
 Emergency call buttons, 76
 Emergency services exchange, 78
 Ending a call, 75
 Ending the automatic SOS call, 79
 Ending the automatic SOS call by the SOS call recipient, 79
 Ending the automatic SOS call by the SOS call sender, 79
 Entering names, 83
 Entering text, 83
 Explanations, 74

G

Guarantee, 88

H

Handsfree, 77
 Handsfree button, 73
 Handsfree function, 77
 Handsfree LED, 73
 handsfree volume, 77
 Hash button, 73
 Hearing aid compatibility, 70

I

Icons in the display, 74
 Inserting the batteries, 72
 Installation location, 70
 Intended use, 70

L

Loudspeaker, 73

M

Main menu, 82
 Maintenance, 88
 Making a call, 75
 Menu button, 73
 Menu structure, 82
 Microphone, 73
 Mute the automatic alert message, 82

N

Navigating in the menu, 74
 New calls indicator, 85

O

One-touch dialling buttons, 73, 76
 Operating elements, 73
 Operating the telephone, 74
 Outgoing alert message, 78, 79

Index

P

Package contents, 71
Phone book, 83
Phone book button, 73
Phone book entries, 83
Playing your outgoing alert message, 79
Power adapter plug, 70
Private branch exchanges, 81
Problems, 87
Problems and solutions, 87
Programming one-touch dialling buttons, 76
Programming service buttons, 77
Programming SOS buttons, 76
Pulse, 82
Pulse dialling mode, 82

R

R button on private branch exchanges, 81
R-button, 73
R-button and supplementary services, 81
Receiver, 73
Receiver volume slide control, 73
Record alert message, 82
Recording a name, 84
Recording the outgoing alert message, 79
Redialling, 76
Registering the emergency call unit on the telephone, 80

S

Safety information, 70
Saving, 83
Scroll down button, 73
Scroll up button, 73
Selecting the ringing melody, 82
Service buttons, 73, 77
Service hotline, 87
Setting the contrast, 82
Setting the date and time, 82
Setting the display contrast, 82
Setting the Flash time, 81
Setting the language, 82
Setting the Recall time, 82
Setting the receiver volume, 75
Setting the ringing tone, 82
Setting the ringing volume, 75, 82
SOS alarm, 78
SOS call button, 73
SOS call buttons, 73
Star button, 73
Starting SOS calls, 79
Starting up, 71
Storing numbers from the list in the phone book, 86
Supplementary services, 81
Switching the key tone on/off, 82

T

Taking a call, 75
Talk time, 75
Telephoning, 75
Time, 72
Tone control, 73, 75
Tone dialling mode, 82
Tone slide control, 73
Troubleshooting, 87

V

Voice output for phone book entries, 84

W

Wall installation, 72

SWITEL

Declaration of conformity

Diese Anlage entspricht der europäischen R&TTE Richtlinie.

Für die komplette Konformitätserklärung nutzen Sie bitte den kostenlosen Download von unserer Website www.switel.com.

Cet équipement est conforme à la directive européenne R&TTE.

Pour obtenir la déclaration de conformité intégrale, veuillez vous servir du téléchargement gratuit de notre site Internet www.switel.com.

Quest'apparecchiatura è conforme alla direttiva europea R&TTE.

Per la dichiarazione di conformità completa si prega di voler usufruire del servizio gratuito di download dal nostro sito Internet www.switel.com.

This equipment complies with the European R&TTE directive.

To view the complete Declaration of Conformity, please refer to the free download available at our web site: www.switel.com.

