

Max. zulässige Belastungen
von Einlegeböden in kg

Länge/Di. mm	Stärke/Gr. Spanpl		
	15	18	22
0<400			
401<600	40	40	40
601<800	24		
801<1000	15	30	

MONTAGEANLEITUNG

Pflegehinweis!







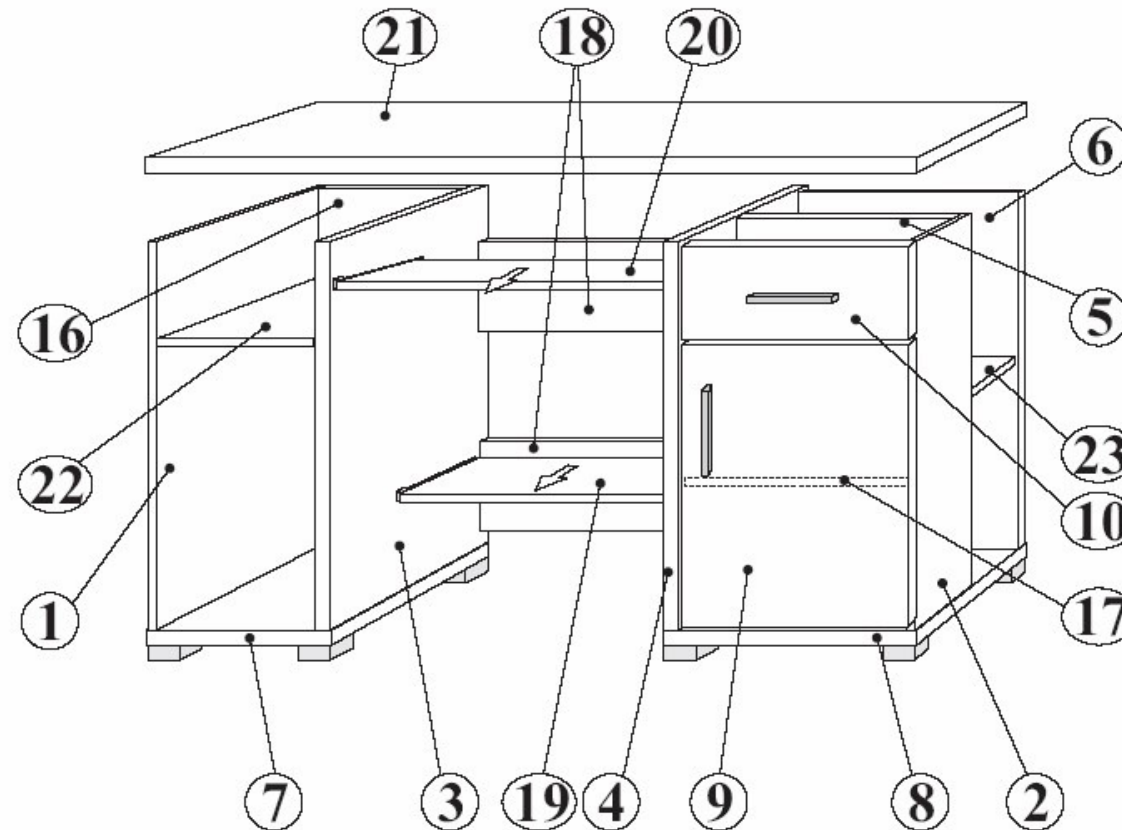
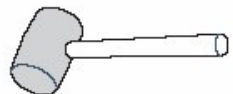
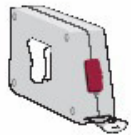











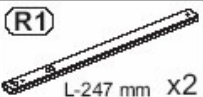

Bitte nur mit einem Staubtuch oder einem feuchten Lappen reinigen.
KEINE scheuernde Putzmittel verwenden!



2 Personen



BESCHLAGLISTE

<p>NR 1</p> <p>(B1)  \varnothing 8x28 x42</p> <p>(M1)  x42</p> <p>(T1)  x42</p> <p>(W1)  x12</p> <p>(L1)  x1</p>	<p>NR 2</p> <p>(U53)  x2</p> <p>(P4)  4x25 x4</p> <p>NR 6</p> <p>(N19)  x8</p> <p>(S23)  3,5x40 X24</p>	<p>NR 3</p> <p>(R1)  L-247 mm X2</p> <p>(E4)  6x9 x4</p> <p>(A1)  M4x9 mm x2</p>	<p>NR 4</p> <p>(R22) L-350 mm  x1R/1L</p> <p>(E2)  6,3x9,5 x4</p> <p>(S3)  3,5x13 x4</p>	<p>NR 5</p> <p>(R21) L-300 mm  x1L/1R</p> <p>(E2)  6,3x9,5 x4</p> <p>(S3)  3,5x13 x4</p>	<p>NR 7</p> <p>(Y0)  Kr0 x2</p> <p>(Y5)  x2</p> <p>(S8)  4x13 x4</p> <p>(E1)  6,3x13 x4</p>
----------------------------------------------------------------------------------------------------------------------------------------------------------------------------------------------------------------------------------------------------------------------------------------------------------------------------------------------------------------------------------------------------------------------------------------------------------------------------------------------------------------------------------------------------------------------------------------------	---------------------------------------------------------------------------------------------------------------------------------------------------------------------------------------------------------------------------------------------------------------------------------------------------------------------------------------------------------------------------------------------------------------------------------------------------------------------------------------	--------------------------------------------------------------------------------------------------------------------------------------------------------------------------------------------------------------------------------------------------------------------------------------------------------------------------------------------------------------------	-----------------------------------------------------------------------------------------------------------------------------------------------------------------------------------------------------------------------------------------------------------------------------------------------------------------------------------------------------------------------------------	-----------------------------------------------------------------------------------------------------------------------------------------------------------------------------------------------------------------------------------------------------------------------------------------------------------------------------------------------------------------------------------	----------------------------------------------------------------------------------------------------------------------------------------------------------------------------------------------------------------------------------------------------------------------------------------------------------------------------------------------------------------------------------------------------------------------------------------------------------------------------



1

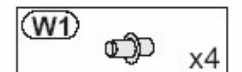
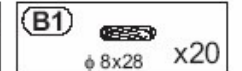
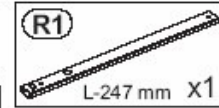
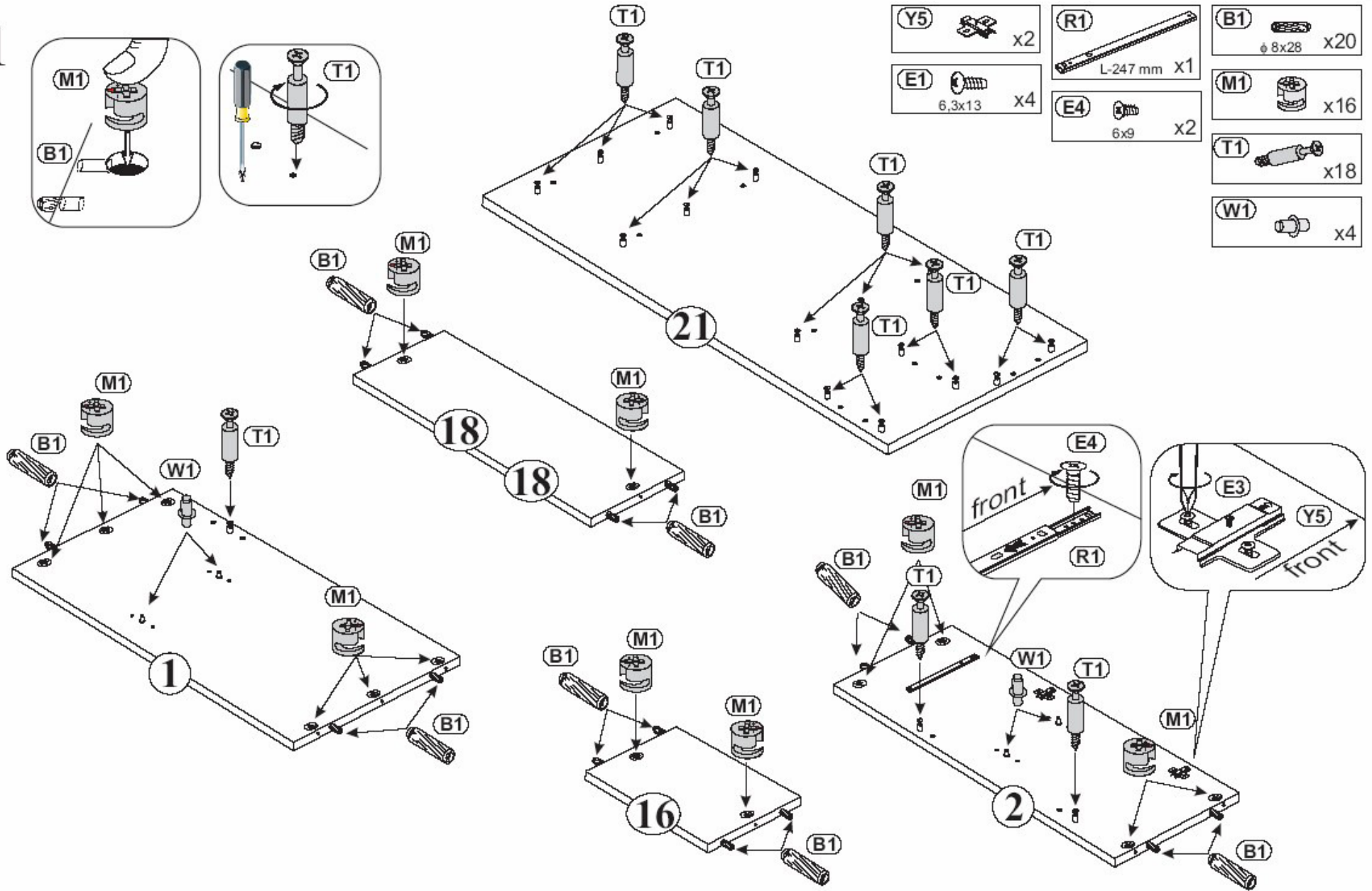
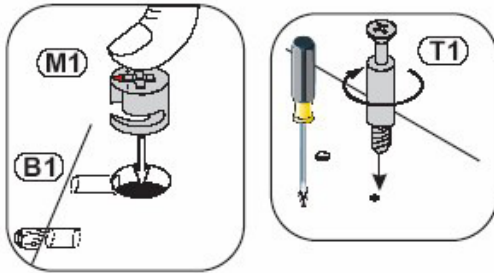

2

- | | | | |
|----------------------------|---------------------------------|---------------------------------|--------------------------|
| (R1)
L-247 mm X1 | (R22) L-350 mm
x1R/1L | (R21) L-300 mm
x1L/1R | (B1)
ø 8x28 x8 |
| (E4)
6x9 x2 | (E2)
6,3x9,5 x4 | (E2)
6,3x9,5 x4 | (M1)
x12 |
| | | | (T1)
x9 |
| | | | (W1)
x4 |

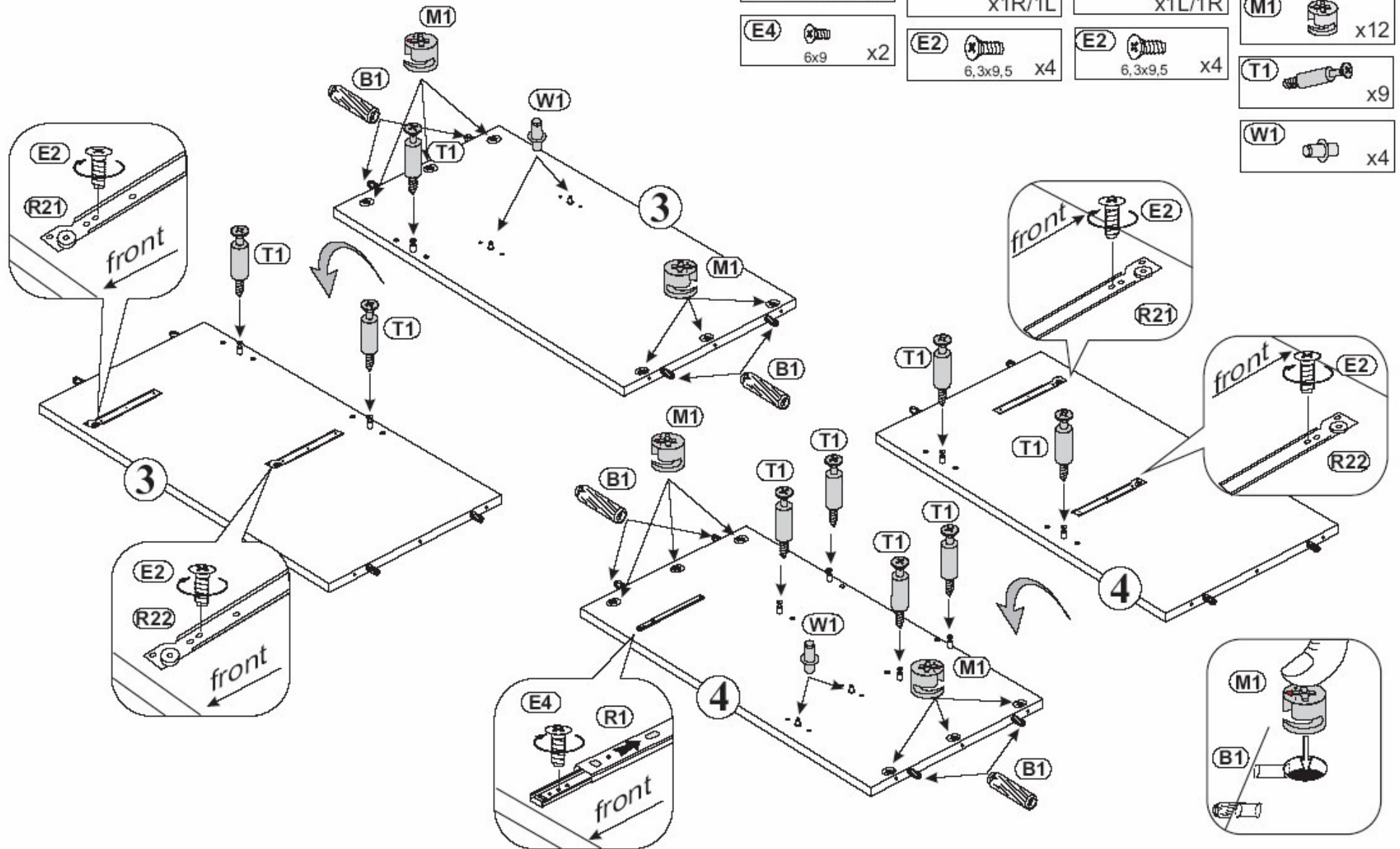

3

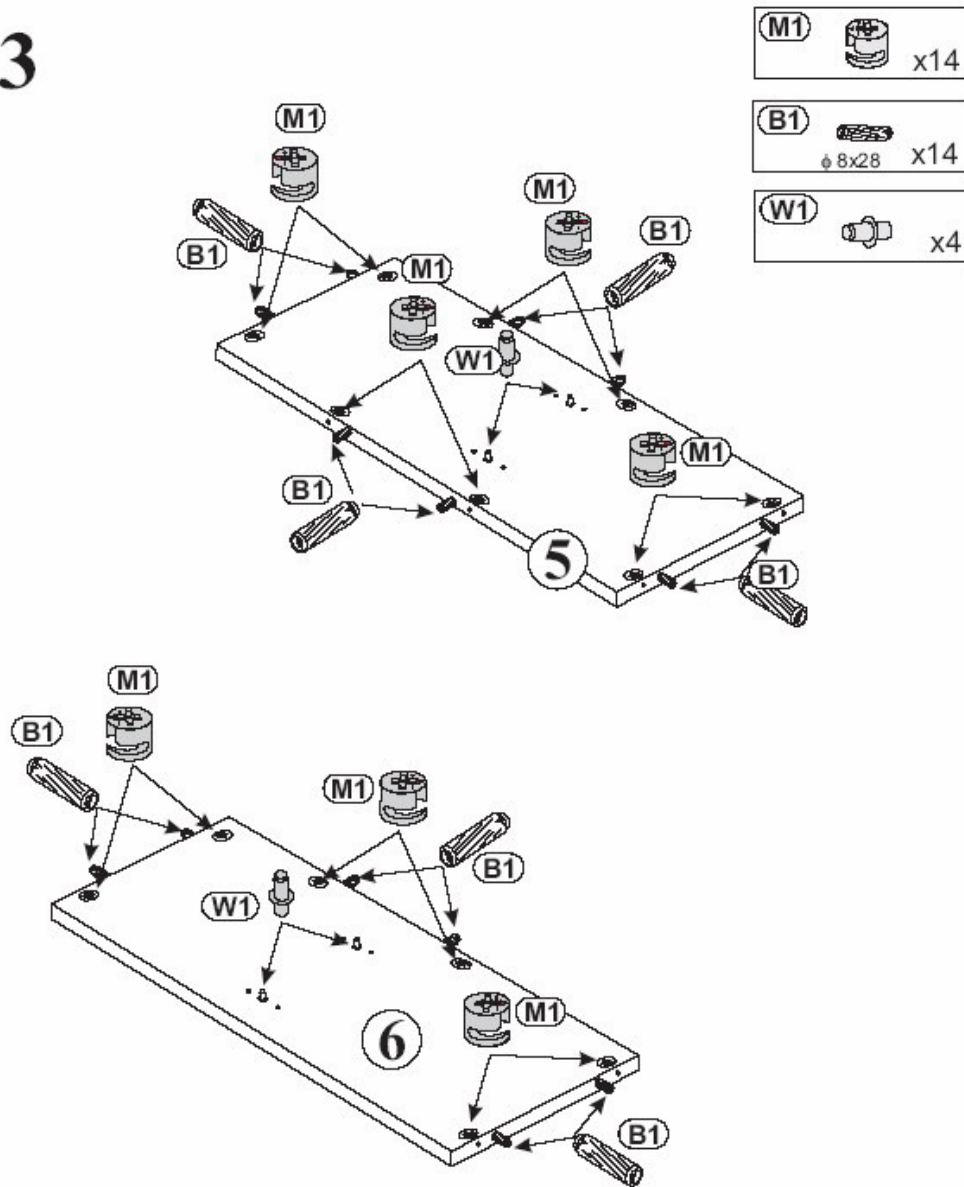

4

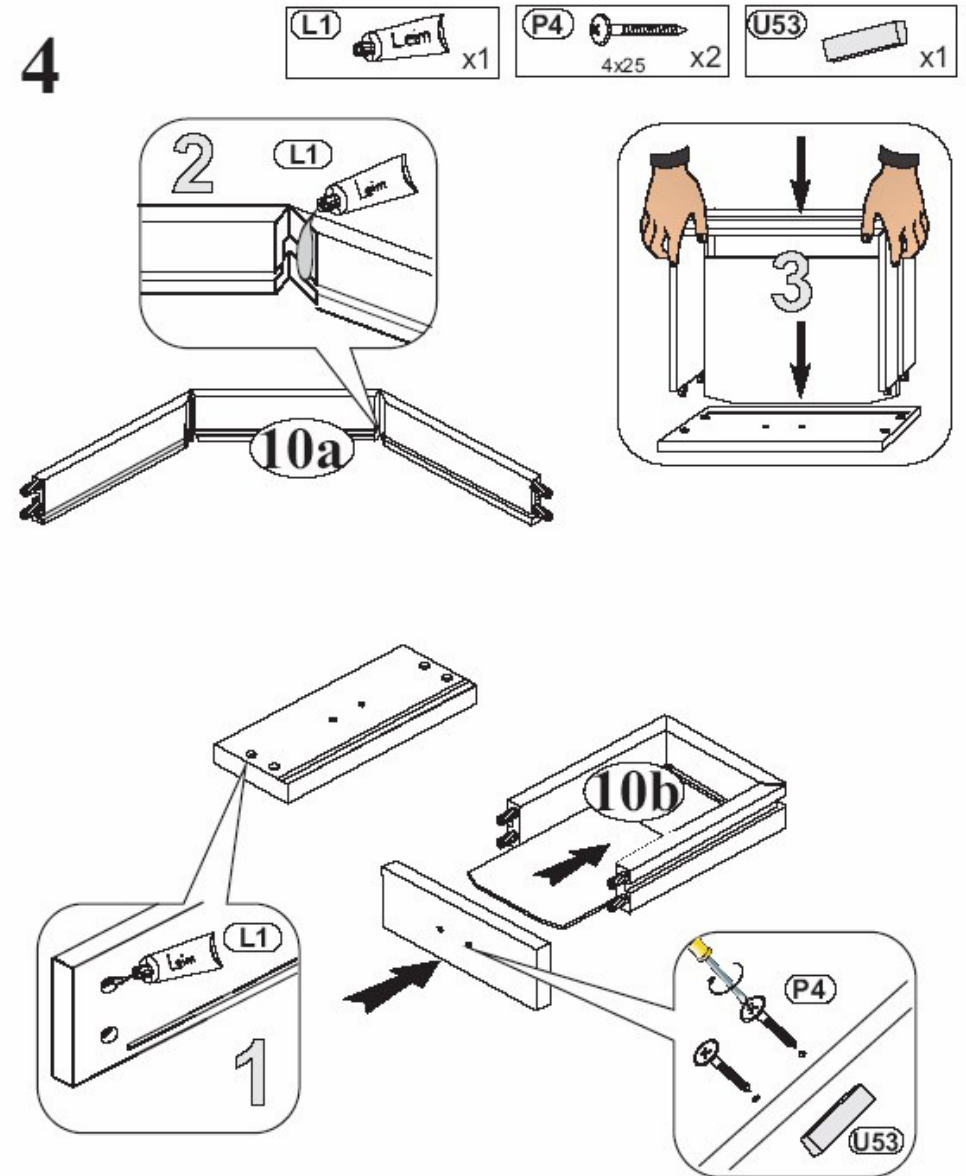

5

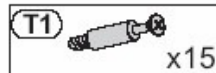
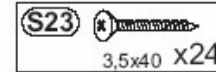
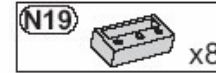
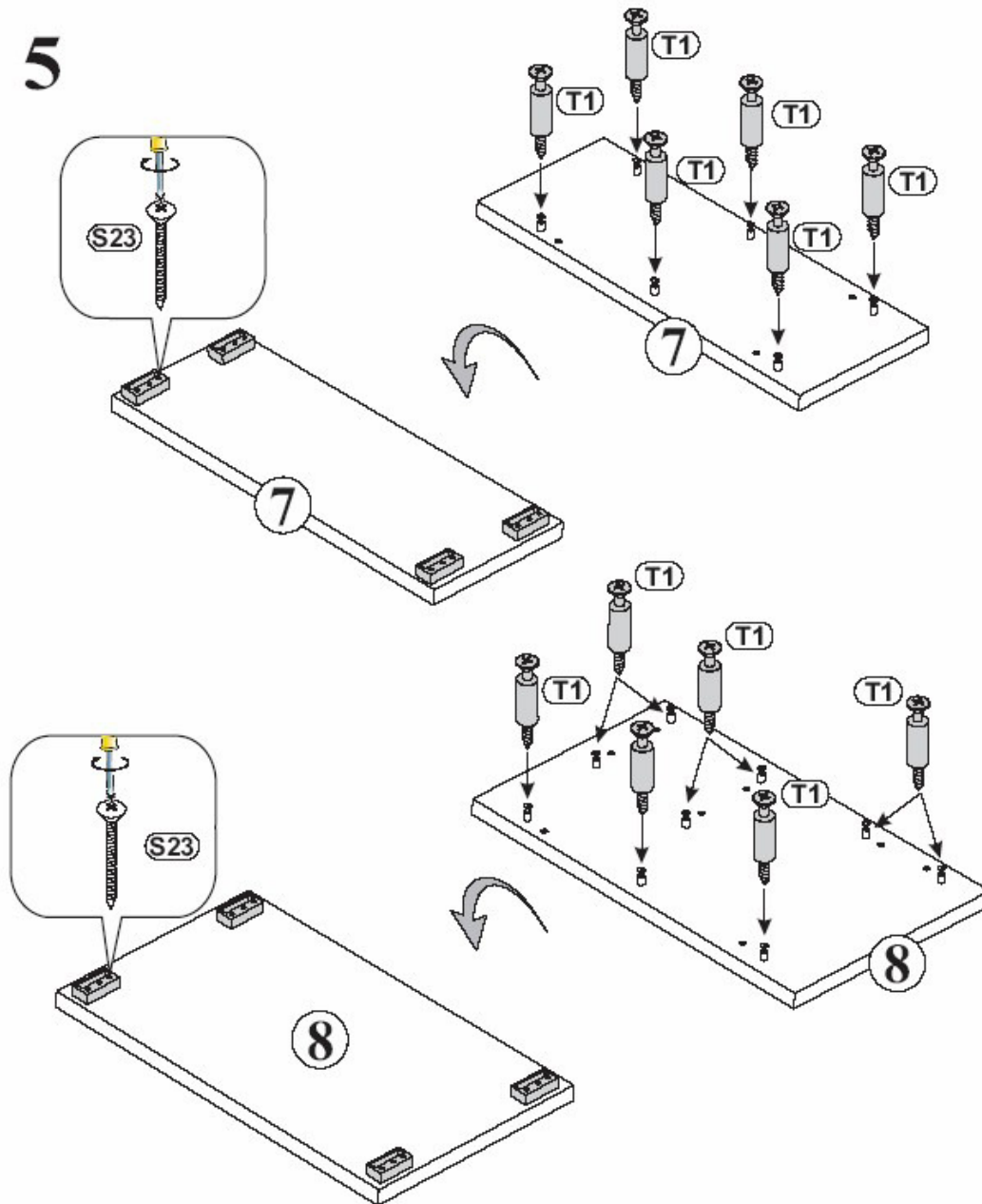

6

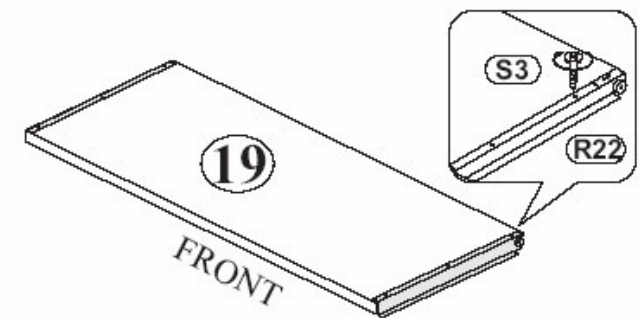
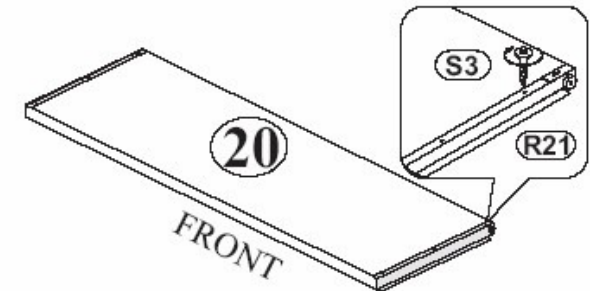
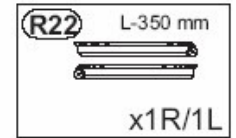
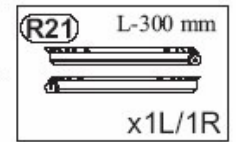
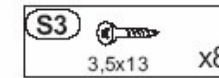

7

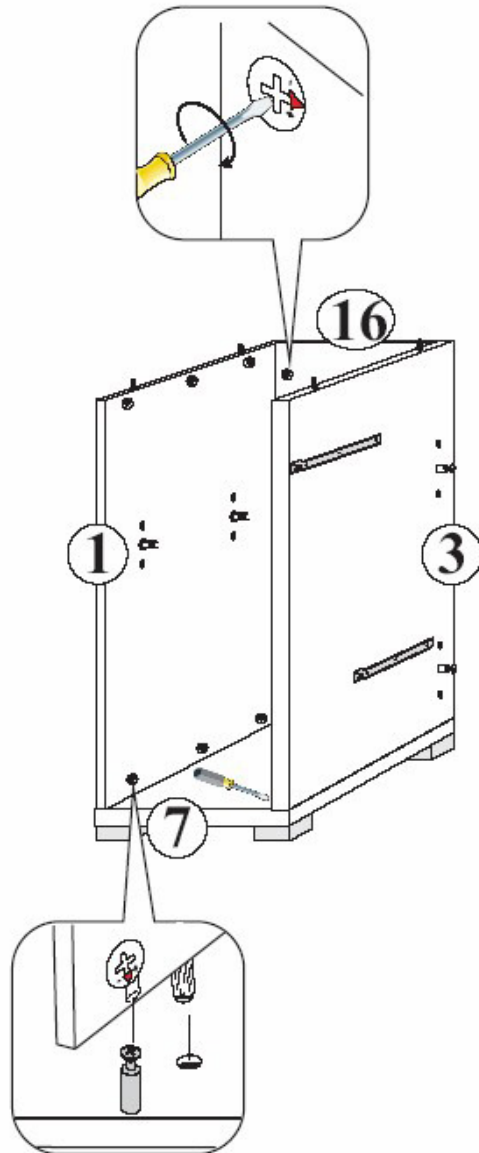

8

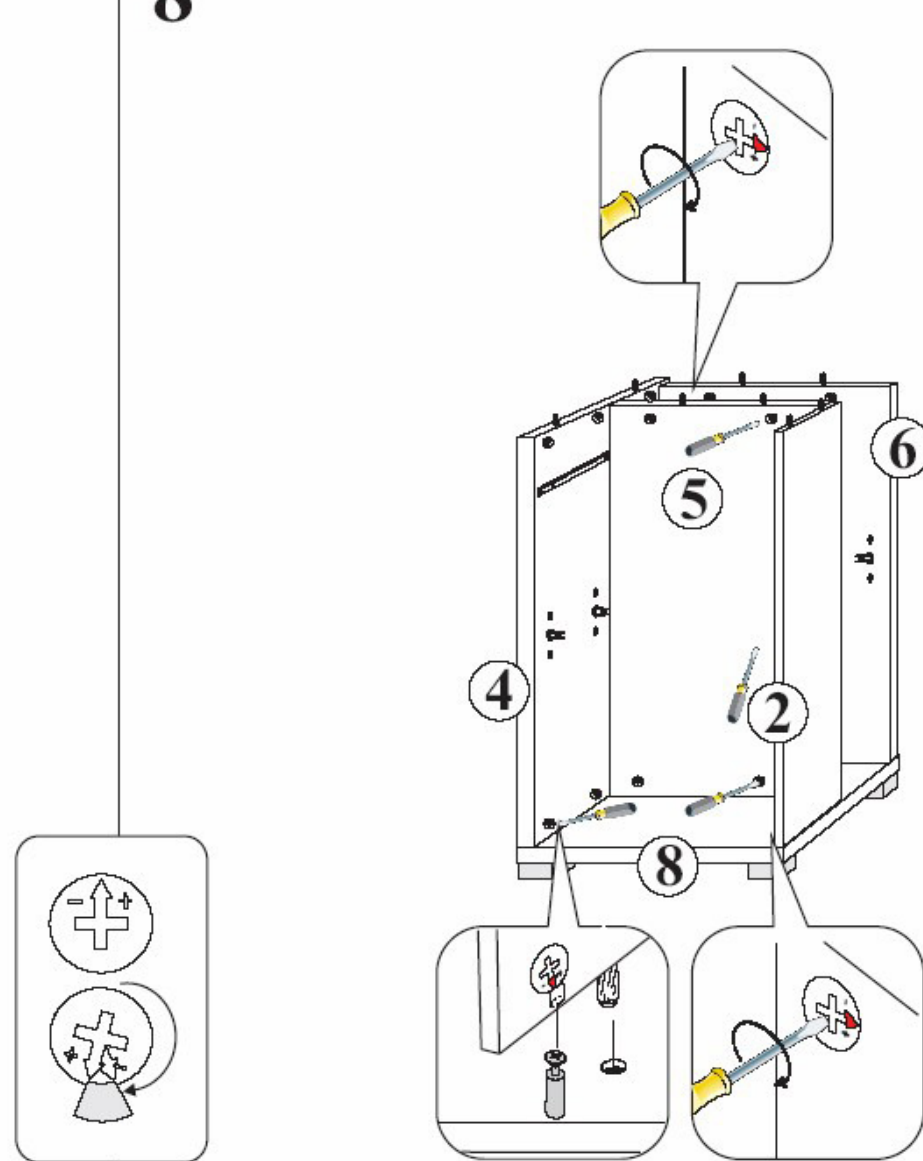



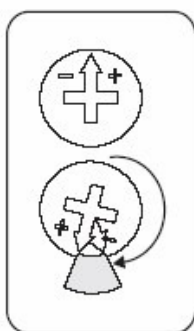
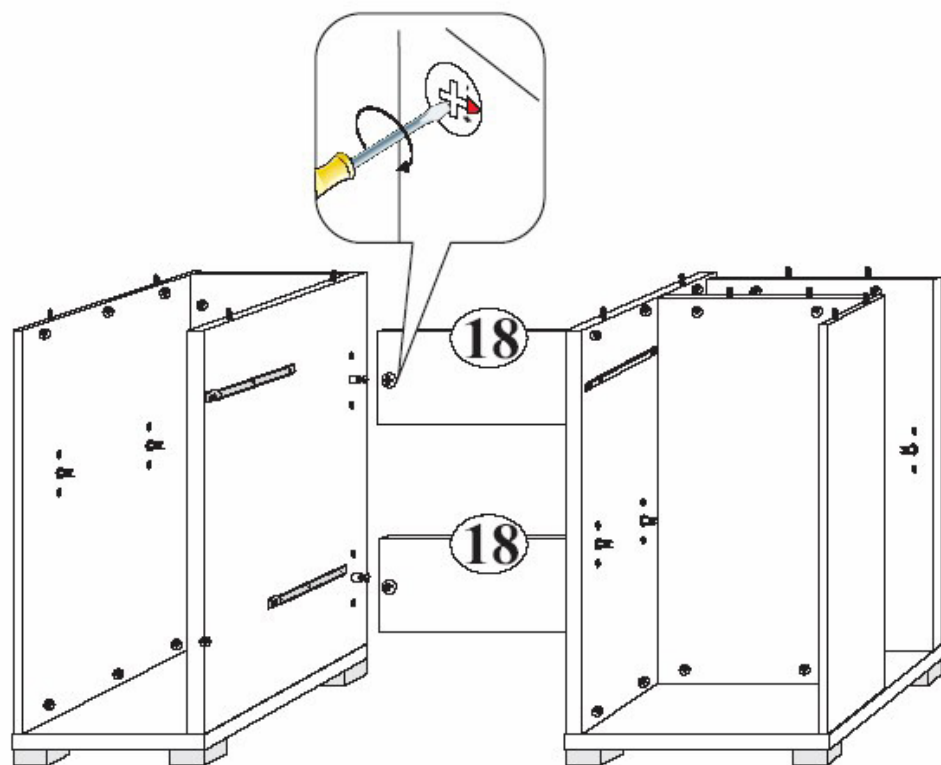

9

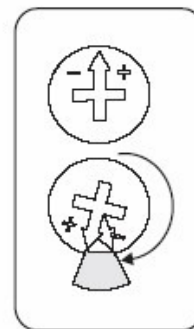
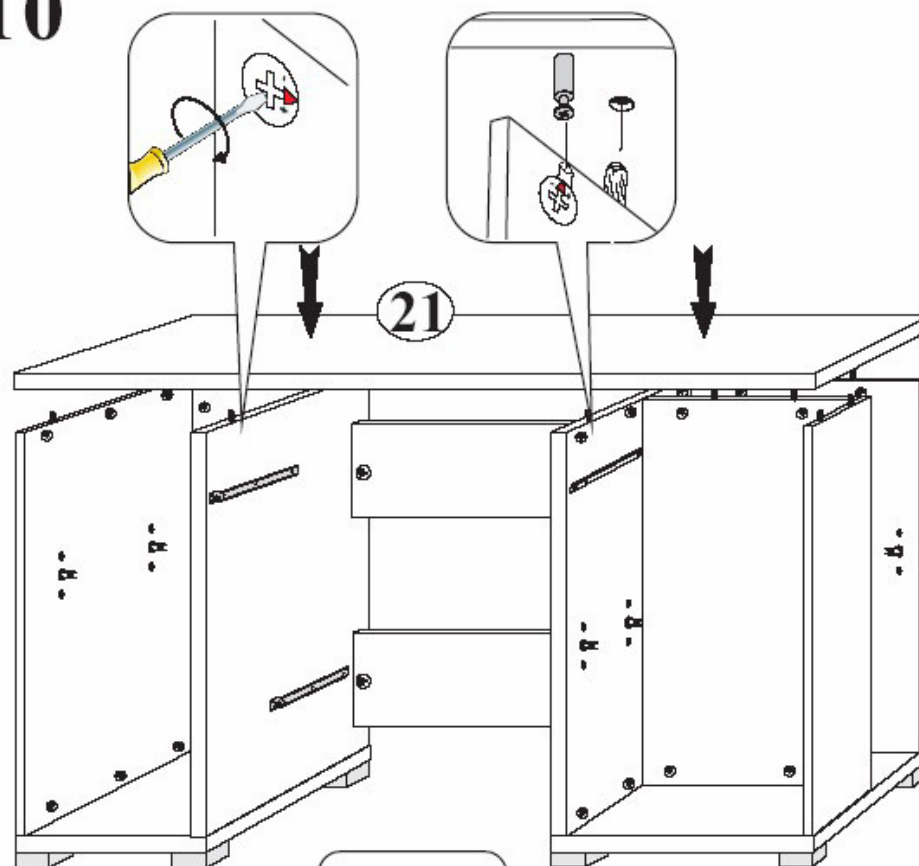

10

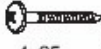

11

- U53**  x1
- Y0**  $\varnothing 26$
K10 x2
- P4**  4x25 x2
- S8**  4x13 x4

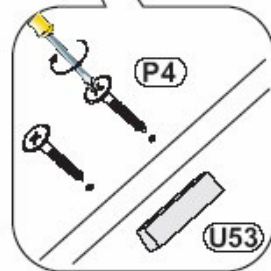
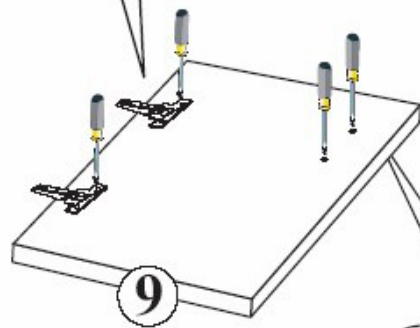
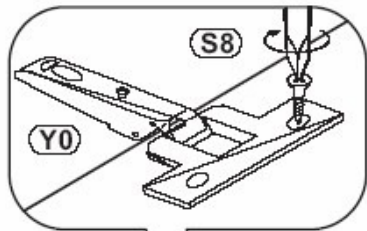

12

- A1**  M4x9 mm x2

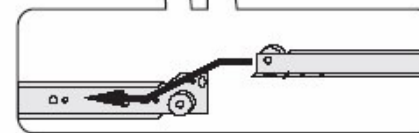
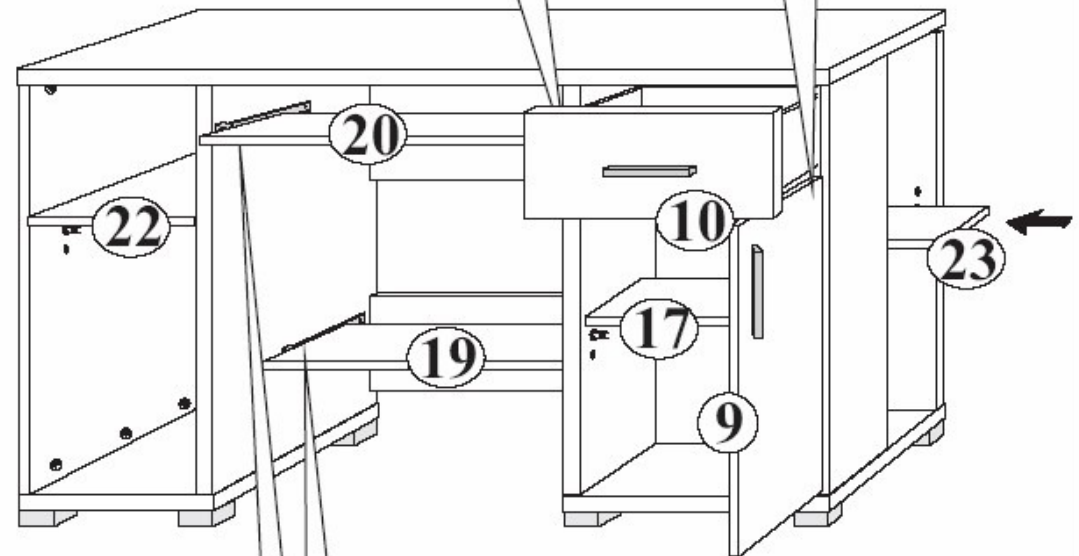
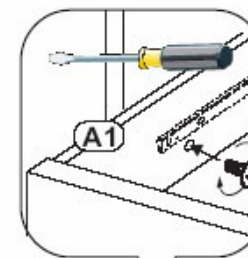

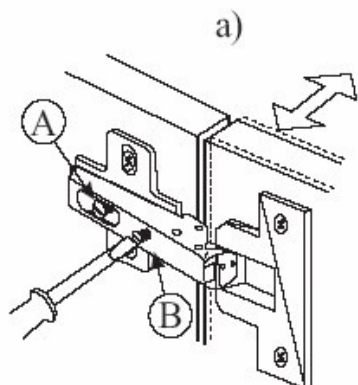

Verstellmöglichkeiten

a) Fugenverstellung:
Befestigungsschraube "A" lockern, gewünschte Fuge mit Schraube "B" einstellen, Schraube "A" anziehen.

b) Tiefenverstellung:
Befestigungsschraube "A" lockern, Bandarm nach vorne oder rückwärts verschieben, Schraube "A" anziehen, Schraube "B" mit einer 1/4 Drehung nach rechts arretieren.

c) Höhenverstellung:
Befestigungsschraube "C" lockern, Höhe einstellen, Schraube "C" anziehen.

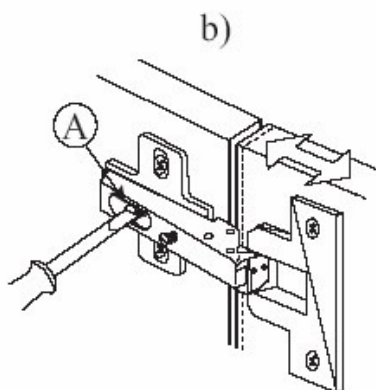

Instructions for hinge adjustment

a) Side adjustment:
Loosen fixing screw "A", adjust gap with screw "B" and retighten screw "A".

b) Depth adjustment:
Loosen fixing screw "A", push hinge arm forward or backward, re-tighten screw "A", fix screw "B" with a 1/4-tur in clock-wise direction.

c) Height adjustment:
Loosen screw "C", adjust height, re-tighten screw "C".

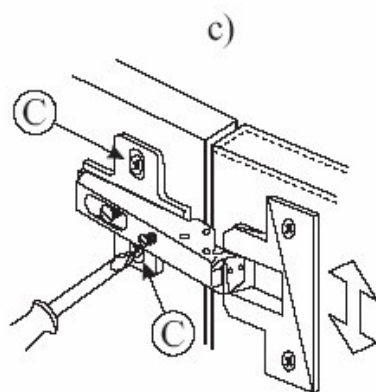

Les possibilités de positionnement

a) Positionnement de la rainure:
Desserrer la vis de fixation "A", positionner avec la vis "B" la rainure (joint) souhaitée et resserrer la vis "A".

b) Positionnement de la profondeur:
Desserrer la vis de fixation "A" (1 tour), régler la profondeur et resserrer la vis "A".

c) Positionnement de la hauteur:
Desserrer la vis de fixation "C" (1 tour), positionner la hauteur et resserrer la vis "C".

Możliwości regulacji

a) Regulacja szczeliny:
Poluzować wkręt "A", wkrętem "B" ustawić odpowiednią szczelinę, dokręcić wkręt "A".

b) Regulacja głębokości:
Poluzować wkręt "A" (1 obrót), ustawić głębokość, dokręcić wkręt "A".

c) Regulacja wysokości:
Poluzować wkręt "C" (1 obrót), dokonać regulacji wysokości położenia drzwi, wkręt "C" dokręcić.