

# STANLEY®

## FATMAX®

EN

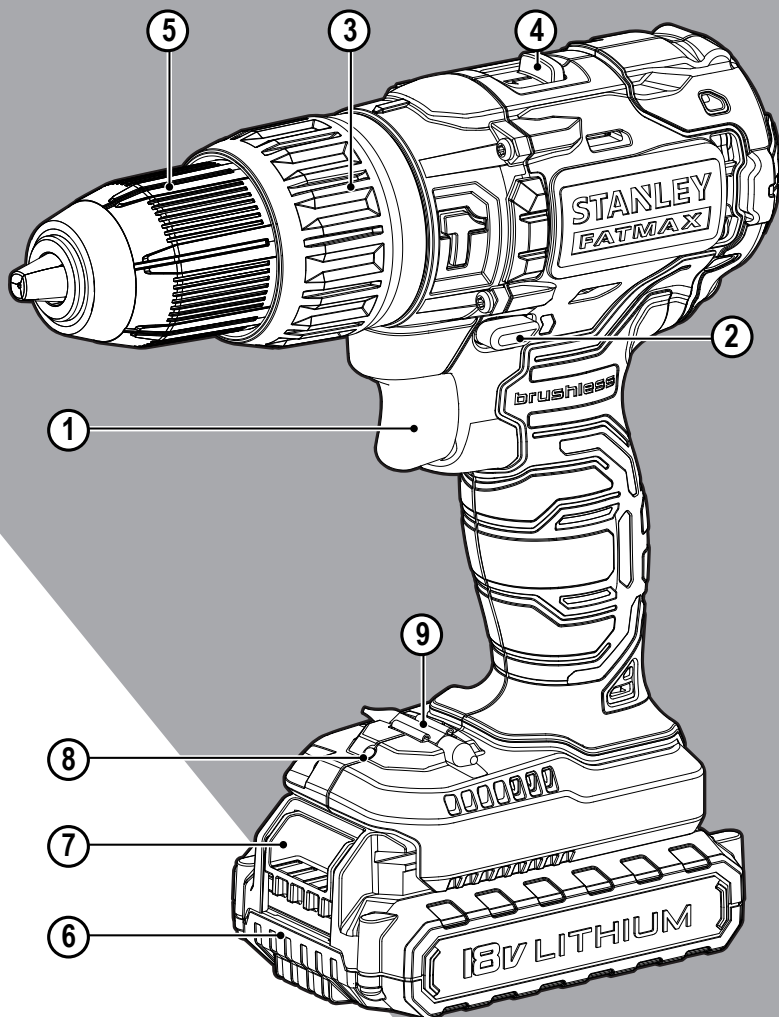

[www.stanley.eu](http://www.stanley.eu)

FMC628

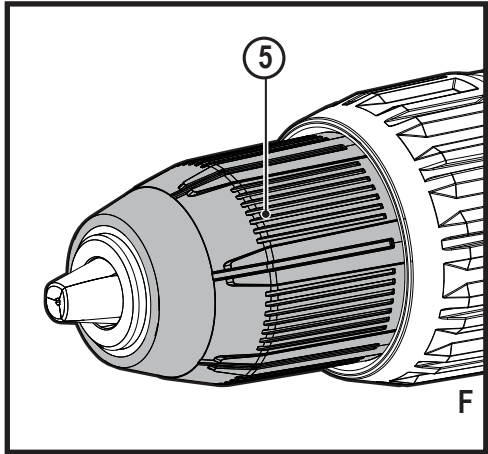
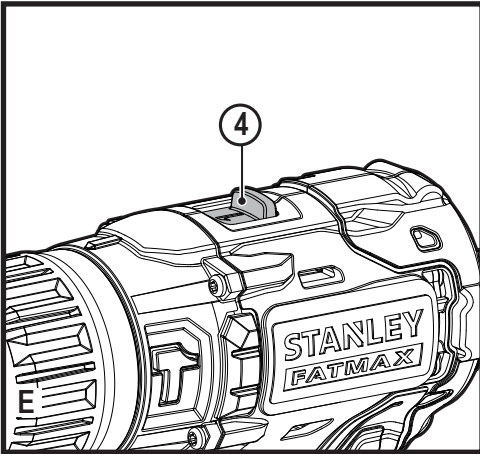
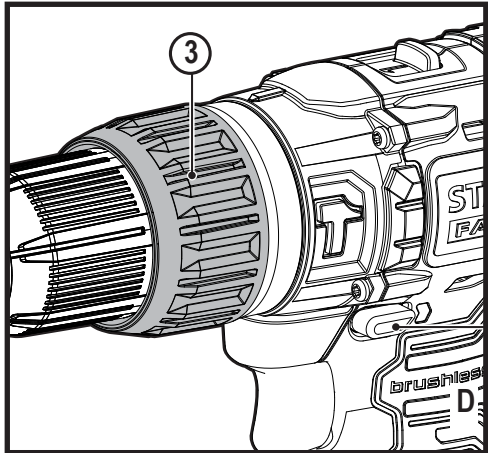
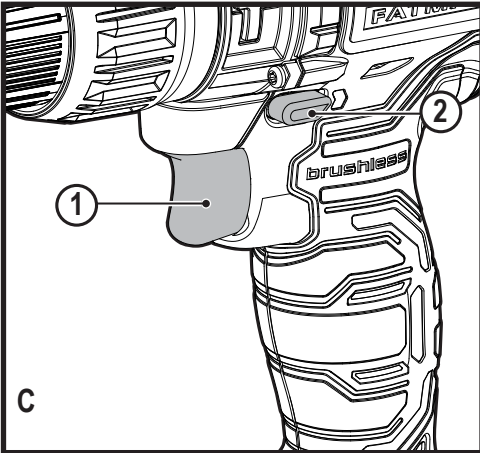
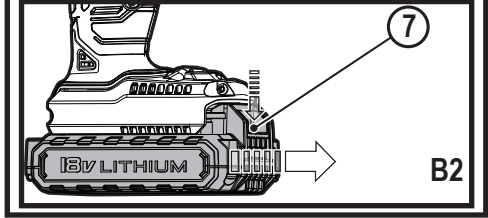
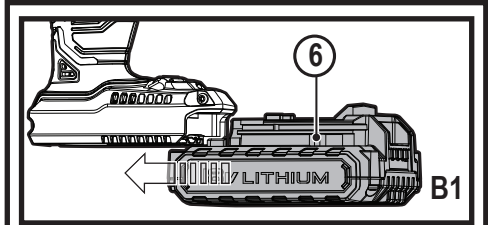
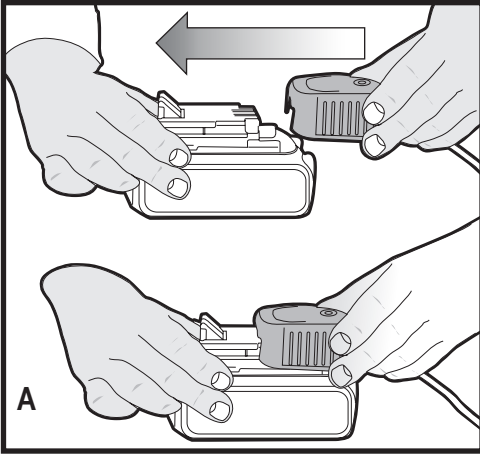

## Intended use

Your Stanley Fat Max FMC628 hammer drill/screwdriver has been designed for screwdriving applications and for drilling in wood, metal, plastics and soft masonry. This tool is intended for professional and private, non professional users.

## Safety instructions

### General power tool safety warnings



**Warning! Read all safety warnings and all instructions.** Failure to follow the warnings and instructions listed below may result in electric shock, fire and/or serious injury.

### Save all warnings and instructions for future reference.

The term "power tool" in all of the warnings listed below refers to your mains operated (corded) power tool or battery operated (cordless) power tool.

1. **Work area safety**
  - a. **Keep work area clean and well lit.** Cluttered or dark areas invite accidents.
  - b. **Do not operate power tools in explosive atmospheres, such as in the presence of flammable liquids, gases or dust.** Power tools create sparks which may ignite the dust or fumes.
  - c. **Keep children and bystanders away while operating a power tool.** Distractions can cause you to lose control.
2. **Electrical safety**
  - a. **Power tool plugs must match the outlet. Never modify the plug in any way. Do not use any adapter plugs with earthed (grounded) power tools.** Unmodified plugs and matching outlets will reduce risk of electric shock.
  - b. **Avoid body contact with earthed or grounded surfaces such as pipes, radiators, ranges and refrigerators.** There is an increased risk of electric shock if your body is earthed or grounded.
  - c. **Do not expose power tools to rain or wet conditions.** Water entering a power tool will increase the risk of electric shock.
  - d. **Do not abuse the cord. Never use the cord for carrying, pulling or unplugging the power tool. Keep cord away from heat, oil, sharp edges or moving parts.** Damaged or entangled cords increase the risk of electric shock.
  - e. **When operating a power tool outdoors, use an extension cord suitable for outdoor use.** Use of a cord suitable for outdoor use reduces the risk of electric shock.
  - f. **If operating a power tool in a damp location is unavoidable, use a residual current device (RCD) protected supply.**
3. **Personal safety**
  - a. **Stay alert, watch what you are doing and use common sense when operating a power tool. Do not use a power tool while you are tired or under the influence of drugs, alcohol or medication.** A moment of inattention while operating power tools may result in serious personal injury.
  - b. **Use personal protective equipment. Always wear eye protection.** Protective equipment such as dust mask, non-skid safety shoes, hard hat, or hearing protection used for appropriate conditions will reduce personal injuries.
  - c. **Prevent unintentional starting. Ensure the switch is in the off-position before connecting to power source and/or battery pack, picking up or carrying the tool.** Carrying power tools with your finger on the switch or energising power tools that have the switch on invites accidents.
  - d. **Remove any adjusting key or wrench before turning the power tool on.** A wrench or a key left attached to a rotating part of the power tool may result in personal injury.
  - e. **Do not overreach. Keep proper footing and balance at all times.** This enables better control of the power tool in unexpected situations.
  - f. **Dress properly. Do not wear loose clothing or jewellery. Keep your hair, clothing and gloves away from moving parts.** Loose clothes, jewellery or long hair can be caught in moving parts.
  - g. **If devices are provided for the connection of dust extraction and collection facilities, ensure these are connected and properly used.** Use of dust collection can reduce dust-related hazards.
4. **Power tool use and care**
  - a. **Do not force the power tool. Use the correct power tool for your application.** The correct power tool will do the job better and safer at the rate for which it was designed.
  - b. **Do not use the power tool if the switch does not turn it on and off.** Any power tool that cannot be controlled with the switch is dangerous and must be repaired.
  - c. **Disconnect the plug from the power source and/or the battery pack from the power tool before making any adjustments, changing accessories, or storing power tools.** Such preventive safety measures reduce the risk of starting the power tool accidentally.
  - d. **Store idle power tools out of the reach of children and do not allow persons unfamiliar with the power tool or these instructions to operate the power tool.** Power tools are dangerous in the hands of untrained users.

Use of an RCD reduces the risk of electric shock.

- e. **Maintain power tools. Check for misalignment or binding of moving parts, breakage of parts and any other condition that may affect the power tools operation. If damaged, have the power tool repaired before use.** Many accidents are caused by poorly maintained power tools.
- f. **Keep cutting tools sharp and clean.** Properly maintained cutting tools with sharp cutting edges are less likely to bind and are easier to control.
- g. **Use the power tool, accessories and tool bits etc. in accordance with these instructions, taking into account the working conditions and the work to be performed.** Use of the power tool for operations different from those intended could result in a hazardous situation.
5. **Battery tool use and care**
- a. **Recharge only with the charger specified by the manufacturer.** A charger that is suitable for one type of battery pack may create a risk of fire when used with another battery pack.
- b. **Use power tools only with specifically designated battery packs.** Use of any other battery packs may create a risk of injury and fire.
- c. **When battery pack is not in use, keep it away from other metal objects, like paper clips, coins, keys, nails, screws, or other small metal objects, that can make a connection from one terminal to another.** Shorting the battery terminals together may cause burns or a fire.
- d. **Under abusive conditions, liquid may be ejected from the battery; avoid contact. If contact accidentally occurs, flush with water. If liquid contacts eyes, additionally seek medical help.** Liquid ejected from the battery may cause irritation or burns.
6. **Service**
- a. **Have your power tool serviced by a qualified repair person using only identical replacement parts.** This will ensure that the safety of the power tool is maintained.

### Additional power tool safety warnings



**Warning!** Additional safety warnings for drills/screwdrivers

- ◆ **Wear ear protectors when impact drilling.** Exposure to noise can cause hearing loss.
- ◆ **Use auxiliary handles supplied with the tool.** Loss of control can cause personal injury.
- ◆ **Hold power tool by insulated gripping surfaces when performing an operation where the cutting accessory may contact hidden wiring.**

Cutting accessory contacting a "live" wire may make exposed metal parts of the power tool "live" and could give the operator an electric shock.

- ◆ **Hold power tool by insulated gripping surfaces, when performing an operation where the fastener may contact hidden wiring.** Fasteners contacting a "live" wire may make exposed metal parts of the power tool "live" and could give the operator an electric shock.
- ◆ **Use clamps or another practical way to secure and support the workpiece to a stable platform.** Holding the work by hand or against your body leaves it unstable and may lead to loss of control.
- ◆ Before drilling into walls, floors or ceilings, check for the location of wiring and pipes.
- ◆ Avoid touching the tip of a drill bit just after drilling, as it may be hot.
- ◆ The intended use is described in this instruction manual. The use of any accessory or attachment or performance of any operation with this tool other than those recommended in this instruction manual may present a risk of personal injury and/or damage to property.

### Safety of others

- ◆ This tool is not intended for use by persons (including children) with reduced physical, sensory or mental capabilities, or lack of experience and knowledge, unless they have been given supervision or instruction concerning use of the tool by a person responsible for their safety.
- ◆ Children should be supervised to ensure that they do not play with the appliance.

### Residual risks

Additional residual risks may arise when using the tool which may not be included in the enclosed safety warnings. These risks can arise from misuse, prolonged use etc.

Even with the application of the relevant safety regulations and the implementation of safety devices, certain residual risks can not be avoided. These include:

- ◆ Injuries caused by touching any rotating/moving parts.
- ◆ Injuries caused when changing any parts, blades or accessories.
- ◆ Injuries caused by prolonged use of a tool. When using any tool for prolonged periods ensure you take regular breaks.
- ◆ Impairment of hearing.
- ◆ Health hazards caused by breathing dust developed when using your tool (example:- working with wood, especially oak, beech and MDF.)

## Vibration

The declared vibration emission values stated in the technical data and the declaration of conformity have been measured in accordance with a standard test method provided by EN 60745 and may be used for comparing one tool with another. The declared vibration emission value may also be used in a preliminary assessment of exposure.

**Warning!** The vibration emission value during actual use of the power tool can differ from the declared value depending on the ways in which the tool is used. The vibration level may increase above the level stated.

When assessing vibration exposure to determine safety measures required by 2002/44/EC to protect persons regularly using power tools in employment, an estimation of vibration exposure should consider, the actual conditions of use and the way the tool is used, including taking account of all parts of the operating cycle such as the times when the tool is switched off and when it is running idle in addition to the trigger time.

## Labels on tool

The following symbols are shown on the tool along with the date code:



**Warning!** To reduce the risk of injury, the user must read the instruction manual.



Wear ear protectors with impact drills. Exposure to noise can cause hearing loss.

## Additional safety instructions for batteries and chargers (Not provided with the tool)

### Batteries

- ◆ Never attempt to open for any reason.
- ◆ Do not expose the battery to water.
- ◆ Do not store in locations where the temperature may exceed 40 °C.
- ◆ Charge only at ambient temperatures between 10 °C and 40 °C.
- ◆ Charge only using the charger provided with the tool.
- ◆ When disposing of batteries, follow the instructions given in the section "Protecting the environment".



Do not attempt to charge damaged batteries.

### Chargers

- ◆ Use your Stanley Fat Max charger only to charge the battery in the tool with which it was supplied. Other batteries could burst, causing personal injury and damage.
- ◆ Never attempt to charge non-rechargeable batteries.

- ◆ Have defective cords replaced immediately.
- ◆ Do not expose the charger to water.
- ◆ Do not open the charger.
- ◆ Do not probe the charger.



The charger is intended for indoor use only.



Read the instruction manual before use.

## Electrical safety



Your charger is double insulated; therefore no earth wire is required. Always check that the mains voltage corresponds to the voltage on the rating plate. Never attempt to replace the charger unit with a regular mains plug.

- ◆ If the supply cord is damaged, it must be replaced by the manufacturer or an authorised Stanley Fat Max Service Centre in order to avoid a hazard.

## Features

This appliance includes some or all of the following features.

1. Trigger Switch
2. Forward/Reverse Button
3. Torque Adjust Collar
4. Dual Range Gear Selector
5. Keyless Chuck
6. Battery
7. Battery Release Button
8. LED Work Light
9. Bit Tip Holder

## Use

**Warning!** Let the tool work at its own pace. Do not overload.

## Charging the battery

The battery needs to be charged before first use and whenever it fails to produce sufficient power on jobs that were easily done before. The battery may become warm while charging; this is normal and does not indicate a problem.

**Warning!** Do not charge the battery at ambient temperatures below 10 °C or above 40 °C. Recommended charging temperature: approx. 24 °C.

**Note:** The charger will not charge a battery if the cell temperature is below approximately 10 °C or above 40 °C.

The battery should be left in the charger and the charger will begin to charge automatically when the cell temperature warms up or cools down.

- ◆ Plug the charger into an appropriate outlet before inserting the battery pack.
- ◆ Insert the battery pack into the charger.



The green LED will flash indicating that the battery is being charged.



The completion of charge is indicated by the green LED remaining on continuously. The pack is fully charged and may be used at this time or left in the charger.

**Warning!** Recharge discharged batteries as soon as possible after use or battery life may be greatly diminished.

### Charger diagnostics

This charger is designed to detect certain problems that can arise with the battery packs or the power source. Problems are indicated by one LED flashing in different patterns.

#### Bad Battery



The charger can detect a weak or damaged battery. The red LED flashes in the pattern indicated on the label. If you see this bad battery blink pattern, do not continue to charge the battery. Return it to a service centre or a collection site for recycling.

#### Hot/Cold Pack Delay



When the charger detects a battery that is excessively hot or excessively cold, it automatically starts a Hot/Cold Pack delay, suspending charging until the battery has normalised. After this happens, the charger automatically switches to the Pack Charging mode. This feature ensures maximum battery life. The red LED flashes in the pattern indicated on the label when the Hot/Cold pack delay is detected.

#### Problem Power Line



When the charger is used with some portable power sources such as generators or sources that convert DC to AC, the charger may temporarily suspend operation. The LED flashes in the pattern indicated on the label. This indicates that the power source is out of limits..

### Leaving the battery in the charger

The charger and battery pack can be left connected with the LED glowing indefinitely. The charger will keep the battery pack fresh and fully charged.

### Important charging Notes

- ◆ Longest life and best performance can be obtained if the battery pack is charged when the air temperature is between 65°F and 75°F (18° - 24°C). DO NOT charge the battery pack in an air temperature below +40°F (+4.5°C), or above +105°F (+40.5°C). This is important and will prevent serious damage to the battery pack.
- ◆ The charger and battery pack may become warm to touch while charging. This is a normal condition, and does not indicate a problem. To facilitate the cooling of the battery pack after use, avoid placing the charger or battery pack in a warm environment such as in a metal shed, or an uninsulated trailer.
- ◆ If the battery pack does not charge properly:
  - ◆ Check current at receptacle by plugging in a lamp or other appliance.
  - ◆ Check to see if receptacle is connected to a light switch which turns power off when you turn out the lights.
  - ◆ Move charger and battery pack to a location where the surrounding air temperature is approximately 65°F - 75°F (18° - 24°C).
  - ◆ If charging problems persist, take the tool, battery pack and charger to your local Stanley Fat Max service center.
- ◆ The battery pack should be recharged when it fails to produce sufficient power on jobs which were easily done previously.
- ◆ DO NOT CONTINUE to use under these conditions. Follow the charging procedure.
- ◆ You may also charge a partially used pack whenever you desire with no adverse affect on the battery pack.

### Installing and Removing the Battery Pack from the tool

**Warning!** Make certain the lock-off button is engaged to prevent switch actuation before removing or installing battery.

#### To install battery pack

- ◆ Insert battery pack firmly into tool until an audible click is heard as shown in figure B1. Ensure battery pack is fully seated and fully latched into position.

#### To remove battery pack

- ◆ Depress the battery release button (7) as shown in figure B2 and pull battery pack out of tool.

### Trigger switch & forward/reverse button - figure C

- ◆ The drill is turned ON and OFF by pulling and releasing the trigger switch (1) shown in figure C.

The farther the trigger is depressed, the higher the speed of the drill.

- ◆ A forward/reverse control button (2) determines the rotational direction of the tool and also serves as a lock off button.
- ◆ To select forward rotation, release the trigger switch and depress the forward/reverse control button on the right side of the tool.
- ◆ To select reverse, depress the forward/reverse control button on the left side of the tool.
- ◆ The center position of the control button locks the tool in the off position. When changing the position of the control button, be sure the trigger is released.

### Adjusting torque control - figure D

This tool is fitted with a torque adjustment collar (3) to select the operating mode and to set the torque for tightening screws. Large screws and hard workpiece materials require a higher torque setting than small screws and soft workpiece materials.

- ◆ For drilling in wood, metal and plastics, set the collar to the drilling position symbol.
- ◆ For screwdriving, set the collar to the desired setting. If you do not yet know the appropriate setting, proceed as follows:
  - ◆ Set the collar to the lowest torque setting.
  - ◆ Tighten the first screw.
  - ◆ If the clutch ratchets before the desired result is achieved, increase the collar setting and continue tightening the screw.
  - ◆ Repeat until you reach the correct setting.
  - ◆ Use this setting for the remaining screws.

### Dual range switch - figure E

The dual range feature of your drill allows you to shift gears for greater versatility.

- ◆ To select low speed, high torque setting (position 1), turn tool off and permit to stop. Slide gear shifter button (4) away from the chuck.
- ◆ To select the high speed, low torque setting (position 2), turn tool off and permit to stop. Slide gear shifter button back toward the chuck.

**Note:** Do not change gears when tool is running. If you are having trouble changing gears, make sure that the dual range gear button is either completely pushed forward or completely pushed back.

### keyless chuck - figure F

**Warning!** Make certain the battery pack is removed to prevent tool actuation before installing or removing accessories.

To insert a drill bit or other accessory:

- ◆ Grasp the chuck (5) and rotate it in the counterclockwise direction, as viewed from the chuck end.

- ◆ Insert the bit or other accessory fully into the chuck, and tighten securely by rotating the chuck in the clockwise direction as viewed from the chuck end.

**Warning!** Do not attempt to tighten or loosen drill bits (or any other accessory) by gripping the front part of the chuck and turning the tool on. Damage to the chuck and personal injury may occur when changing accessories.

### Hammer Action

The FMC628 drill has hammer action which is engaged by twisting the collar to the hammer symbol **T**.

Use hammer action when drilling in masonry.

**Warning!** When the torque adjustment collar is in the drill or hammer drill positions, the drill will not clutch. The drill may stall if overloaded, causing a sudden twist.

### Screw driving

- ◆ For driving fasteners, the forward/reverse button should be pushed to the left.
- ◆ Use reverse (button pushed to the right) for removing fasteners.

**Note:** When moving from forward to reverse, or vice versa, always release the trigger switch first.

### Drilling

- ◆ Use sharp drill bits only.
- ◆ Support and secure work properly, as instructed in the Safety Instructions.
- ◆ Use appropriate and required safety equipment, as instructed in the Safety Instructions.
- ◆ Secure and maintain work area, as instructed in the Safety Instructions.
- ◆ Run the drill very slowly, using light pressure, until the hole is started enough to keep the drill bit from slipping out of it.
- ◆ Apply pressure in a straight line with the bit. Use enough pressure to keep the bit biting but not so much as to stall the motor or deflect the bit.
- ◆ Hold the drill firmly with two hands, one hand on the handle, and the other gripping the bottom around the battery area or the auxiliary handle if provided.
- ◆ **DO NOT CLICK THE TRIGGER OF A STALLED DRILL OFF AND ON IN AN ATTEMPT TO START IT. DAMAGE TO THE DRILL CAN RESULT.**
- ◆ Minimize stalling on breakthrough by reducing pressure and slowly drilling through the last part of the hole.
- ◆ Keep the motor running while pulling the bit out of a drilled hole. This will help reduce jamming.
- ◆ Make sure switch turns drill on and off.

### Drilling in wood

Holes in wood can be made with the same twist drill bits used for metal or with spade bits.

These bits should be sharp and should be pulled out frequently when drilling to clear chips from the flutes.

### Drilling in metal

Use a cutting lubricant when drilling metals. The exceptions are cast iron and brass which should be drilled dry. The cutting lubricants that work best are sulphurized cutting oil.

### Drilling in masonry

Shift drill into 'Hammer mode'. Use carbide tipped masonry bits. Refer to drolling section. Keep even force on the drill but not so much that crack the brittle material. A smooth, even flow of dust indicates the proper drilling rate.

### LED work light

When drill is activated by pulling the trigger switch (1), the integrated LED work light (8) will automatically illuminate the work area.

**Note:** The work light is for lighting the immediate work surface and is not intended to be used as a flashlight.

### Bit tip storage

A bit storage slot (9) is built into the base of the tool.

### Troubleshooting

Problem	Possible cause	Possible solution
Unit will not start.	Battery pack not installed properly.	Check battery pack installation.
	Battery pack not charged.	Check battery pack charging requirements
Unit starts immediately upon inserting battery	The switch has been left in the "on" position.	The switch must be moved to "off" to prevent the tool from immediately starting when battery is inserted.
Battery pack will not charge.	Battery pack not inserted into charger.	Insert battery pack into charger until LED lights.
	Charger not plugged in.	Plug charger into a working outlet.
	Surrounding air temperature too hot or too cold.	Move charger and battery pack to a surrounding air temperature of above 40 degrees F (45°C) or below 105 degrees F (+40.5°C)
Unit shuts off abruptly.	Battery pack has reached its maximum thermal limit.	Allow battery pack to cool down.
	Out of charge. (To maximize the life of the battery pack it is designed to shutoff abruptly when the charge is depleted	Place on charger and allow to charge.

### Maintenance

Your Stanley Fat Max tool has been designed to operate over a long period of time with a minimum of maintenance. Continuous satisfactory operation depends upon proper tool care and regular cleaning.

Your charger does not require any maintenance apart from regular cleaning.

**Warning!** Before performing any maintenance on the tool, remove the battery from the tool. Unplug the charger before cleaning it.

- ◆ Regularly clean the ventilation slots in your tool and charger using a soft brush or dry cloth.
- ◆ Regularly clean the motor housing using a damp cloth. Do not use any abrasive or solvent-based cleaner.
- ◆ Regularly open the chuck and tap it to remove any dust from the interior.

### Protecting the environment



Separate collection. Products and batteries marked with this symbol must not be disposed of with normal household waste.

Products and batteries contain materials that can be recovered or recycled reducing the demand for raw materials. Please recycle electrical products and batteries according to local provisions. Further information is available at [www.2helpU.com](http://www.2helpU.com).

### Technical data

		FMC628
<b>Voltage</b>	V <sub>DC</sub>	18V
<b>No-load speed</b>	Min <sup>-1</sup>	0-430/0-1700
<b>Max. torque</b>	Nm	55
<b>Chuck capacity</b>	mm	13
<b>Max Drilling capacity</b>		
<b>Steel/wood</b>	mm	13/35
<b>Weight</b>	kg	1.5

Charger	905998**	906086	906364**
<b>Input voltage</b>	V <sub>AC</sub> 230	230	230
<b>Output voltage</b>	V <sub>DC</sub> 18	18	20
<b>Current</b>	mA 1000	2000	1000
<b>Approx. charge time</b>	Mins 80-240	40-120	80-240

Battery	FMC685L	FMC687L	FMC684L
<b>Voltage</b>	V <sub>AC</sub> 18	18	18
<b>Capacity</b>	Ah 1.5	2.0	1.3
<b>Type</b>	Li-Ion	Li-Ion	Li-Ion



**Level of sound pressure according to EN 60745:**Sound pressure ( $L_{pA}$ ) 93.5 dB(A), uncertainty (K) 3 dB(A)Sound power ( $L_{WA}$ ) 104.5 dB(A), uncertainty (K) 3 dB(A)**Vibration total values (triax vector sum) according to EN 60745:**Drilling into metal ( $a_{h,D}$ ) 1.4 m/s<sup>2</sup>, uncertainty (K) 1.5 m/s<sup>2</sup>Screwdriving without impact ( $a_h$ ) 0.8 m/s<sup>2</sup>, uncertainty (K) 1.5 m/s<sup>2</sup>Impact drilling into concrete ( $a_{h,ID}$ ) 11.3 m/s<sup>2</sup>, uncertainty (K) 1.5m/s<sup>2</sup>**EC declaration of conformity**

MACHINERY DIRECTIVE



FMC628 - Hammer Drill, Screwdriver

Stanley Fat Max declares that these products described under

"technical data" are in compliance with:

2006/42/EC, EN60745-1:2009+A11:2010 EN60745-2-1:2010  
EN60745-2-2:2010These products also comply with Directive  
2014/30/EU and 2011/65/EU.For more information, please contact Stanley Fat Max at the  
following address or refer to the back of the manual.The undersigned is responsible for compilation of the techni-  
cal file and makes this declaration on behalf of  
Stanley Fat Max.

A handwritten signature in black ink, appearing to read 'R. Laverick'. The signature is stylized with large, sweeping loops.

R. Laverick  
Engineering Manager  
Stanley Fat Max Europe, 210 Bath Road, Slough,  
Berkshire, SL1 3YD  
United Kingdom  
20/09/2016

**Guarantee**

Stanley Europe is confident of the quality of its products and offers consumers a 12 month guarantee from the date of purchase. This guarantee is in addition to and in no way prejudices your statutory rights. The guarantee is valid within the territories of the Member States of the European Union and the European Free Trade Area.

To claim on the guarantee, the claim must be in accordance with Black&Decker Terms and Conditions and you will need to submit proof of purchase to the seller or an authorised repair agent. Terms and conditions of the Stanley Europe 1 year guarantee and the location of your nearest authorised repair agent can be obtained on the Internet at [www.2helpU.com](http://www.2helpU.com), or by contacting your local Stanley Europe office at the address indicated in this manual.

Please visit our website [www.stanley.eu/3](http://www.stanley.eu/3) to register your new Stanley Fat Max product and receive updates on new products and special offers.





**United Kingdom**

Stanley Fat Max  
210 Bath Road  
Slough, Berkshire SL1 3YD

Tel. 01753 511234  
Fax 01753 572112  
[www.stanleytools.co.uk](http://www.stanleytools.co.uk)