

D Schutzhaube montieren

GB	Mounting a protective cover
F	Monter le capot de protection
NL	Beschermende kap monteren
I	Montare la cappa di protezione
E	Montar cubierta protectora
S	Montera skyddskåpan
DK	Monter skærmkappe
N	Monter vernehetten
FIN	Suojuksen asentaminen
GR	Τοποθετήστε το προστατευτικό κάλυμμα
CZ	Montování ochranného krytu
PL	Montaż kołpaka ochronnego
RUS	Установить защитный кожух
P	Montar cobertura protectora
H	Védőburkolatot felszerelni
KOR	보호커버 장착

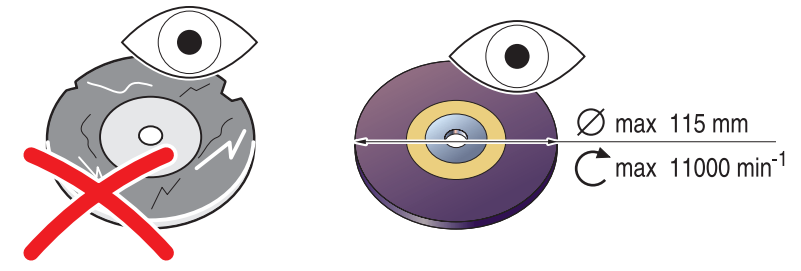
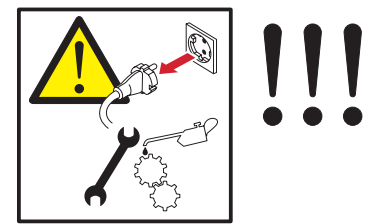
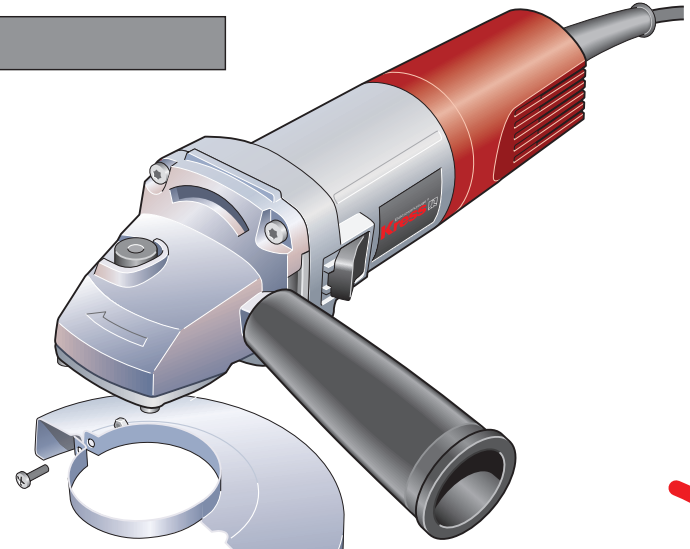

D Scheibe montieren

Mounting a disk	GB
Monter le disque	F
Schijf monteren	NL
Montare la mola	I
Monter disco	E
Montera skivan	S
Monter skive	DK
Monter skiven	N
Hiomalaikan asentaminen	FIN
Τοποθετήστε το δίσκο	GR
Montování kotouče	CZ
Montaż tarczy	PL
Установить Шлифовальный круг	RUS
Montar anel	P
Korongot felszerelni	H
연삭숫돌 장착	KOR

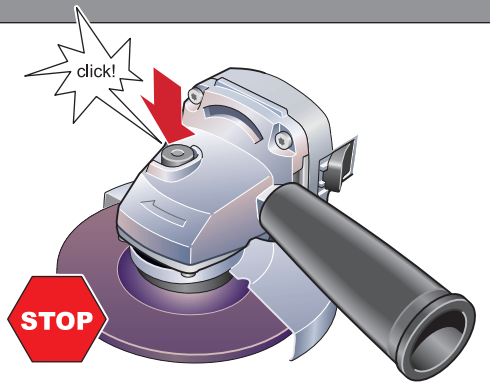

D Sicheres Arbeiten

Save working	GB
Travailler en toute sécurité	F
Veilige werkmethode	NL
Lavoro sicuro	I
Operación segura	E
Säkert arbete	S
Sikkert arbejde	DK
Sikker jobbing	N
Turvallinen toiminta	FIN
Ασφαλής εργασία	GR
Bezpečné pracovní	CZ
Bezpieczna praca	PL
Безопасная работа	RUS
Operação segura	P
Biztonságos munkavégzés	H
작업시 주의사항	KOR

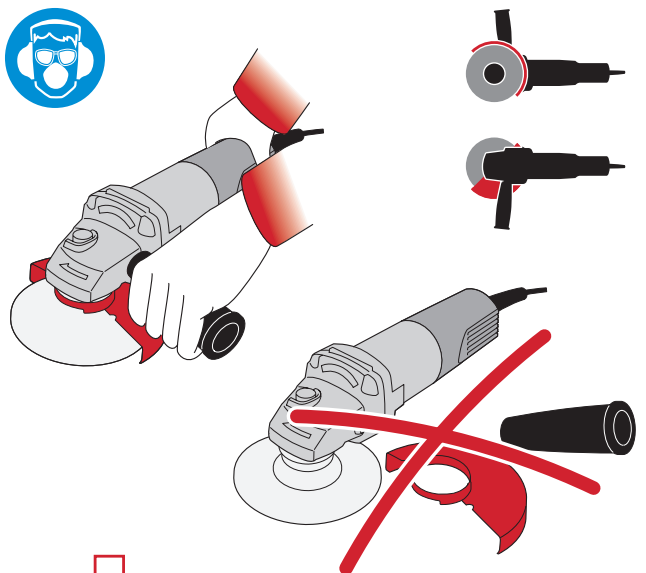

D Ein ① / Aus ②

On / Off	GB
Marche/Arrêt	F
Aan / Uit	NL
On / Off	I
Con / Des	E
Till/Från	S
Til / Fra	DK
På / Av	N
Käynnistys	FIN
Ενεργοποίηση	GR
Zap / Vyp	CZ
Włącz / Wyłącz	PL
Вкл. / Выкл.	RUS
Ligar / Desligar	P
Be / Ki	H
스위치 작동법	KOR

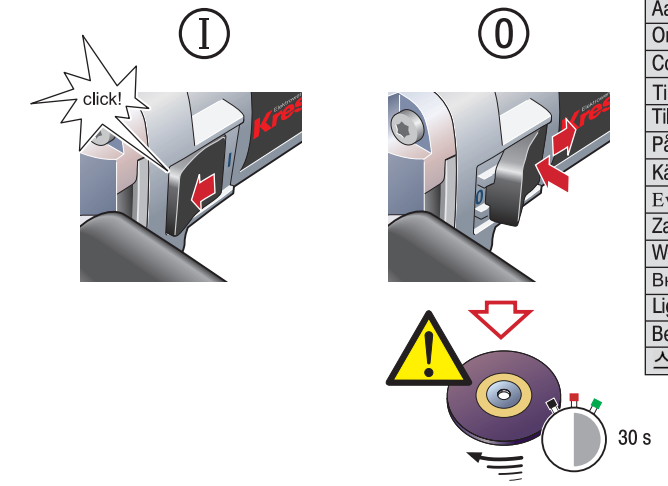

D Kohlebürsten wechseln

Brush replacement	GB
Changer les balais	F
Koolborstels wisselen	NL
Sostituire le spazzole	I
Renovar escobillas de carbón	E
Byta kolborstarna	S
Skift kulbørster	DK
Skift kulbørstene	N
Hiihijarjojen vaihto	FIN
Αντικαταστήστε τις βούρτσες άνθρακα	GR
Výměna uhlíkových kartáčů	CZ
Wymiana szczotek węglowych	PL
Замена угольных щеток	RUS
Renovar escovas de carvão	P
Szénkefeket cserélni	H
카본브러쉬 교환방법	KOR

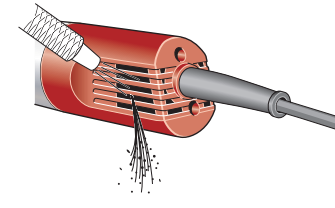
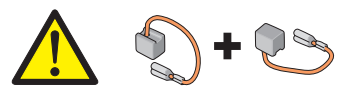
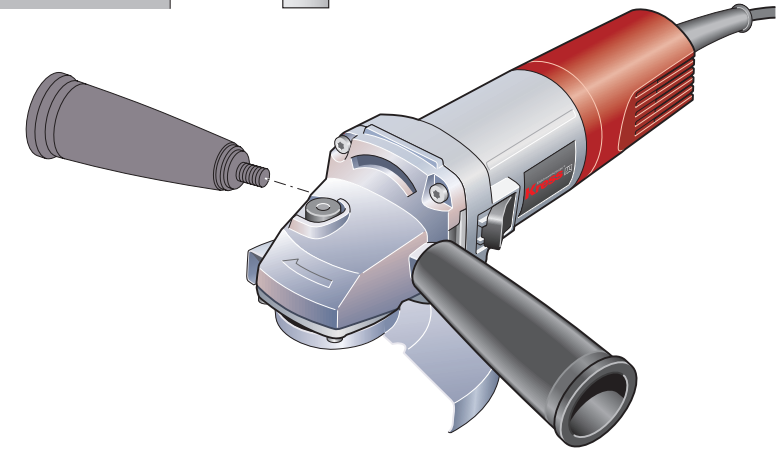
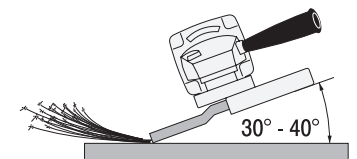
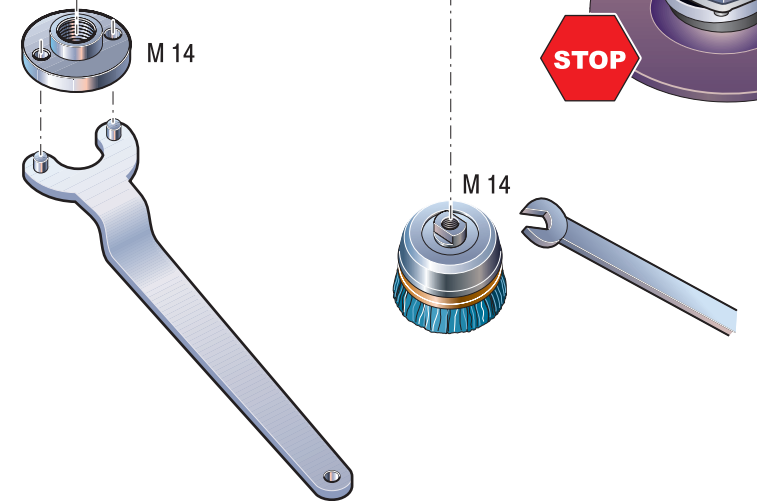
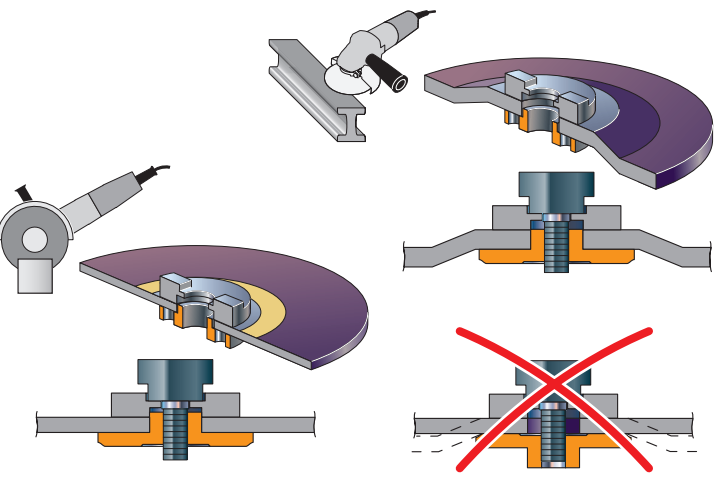
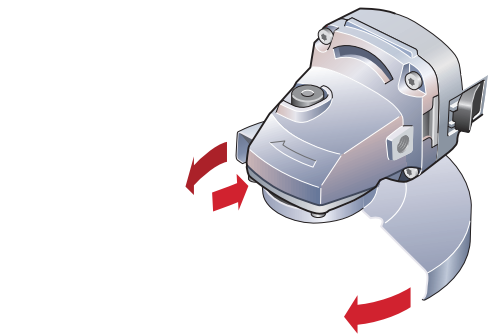
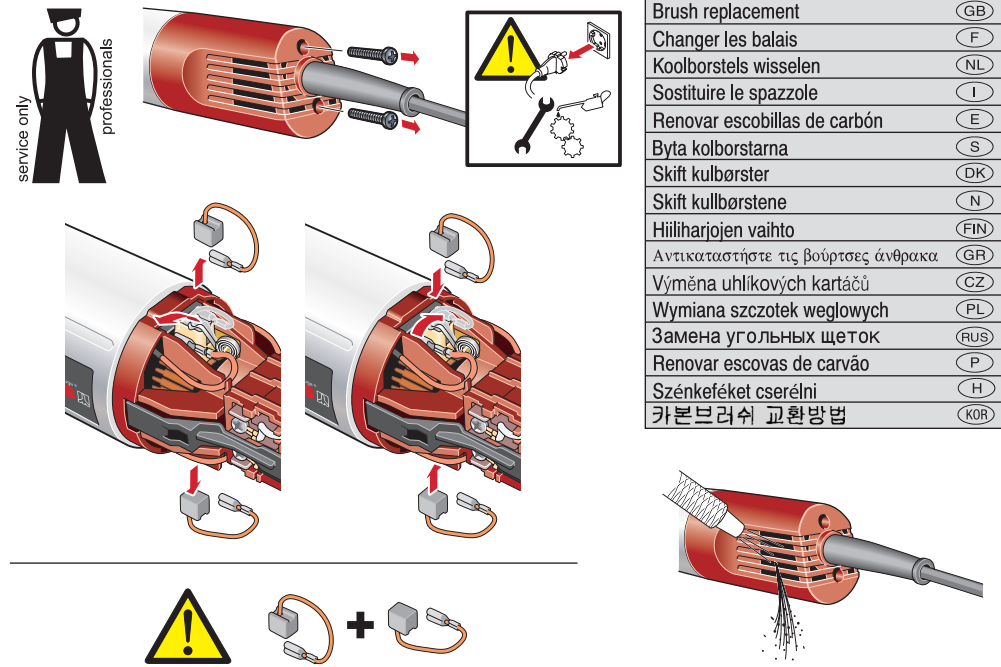



WS 710

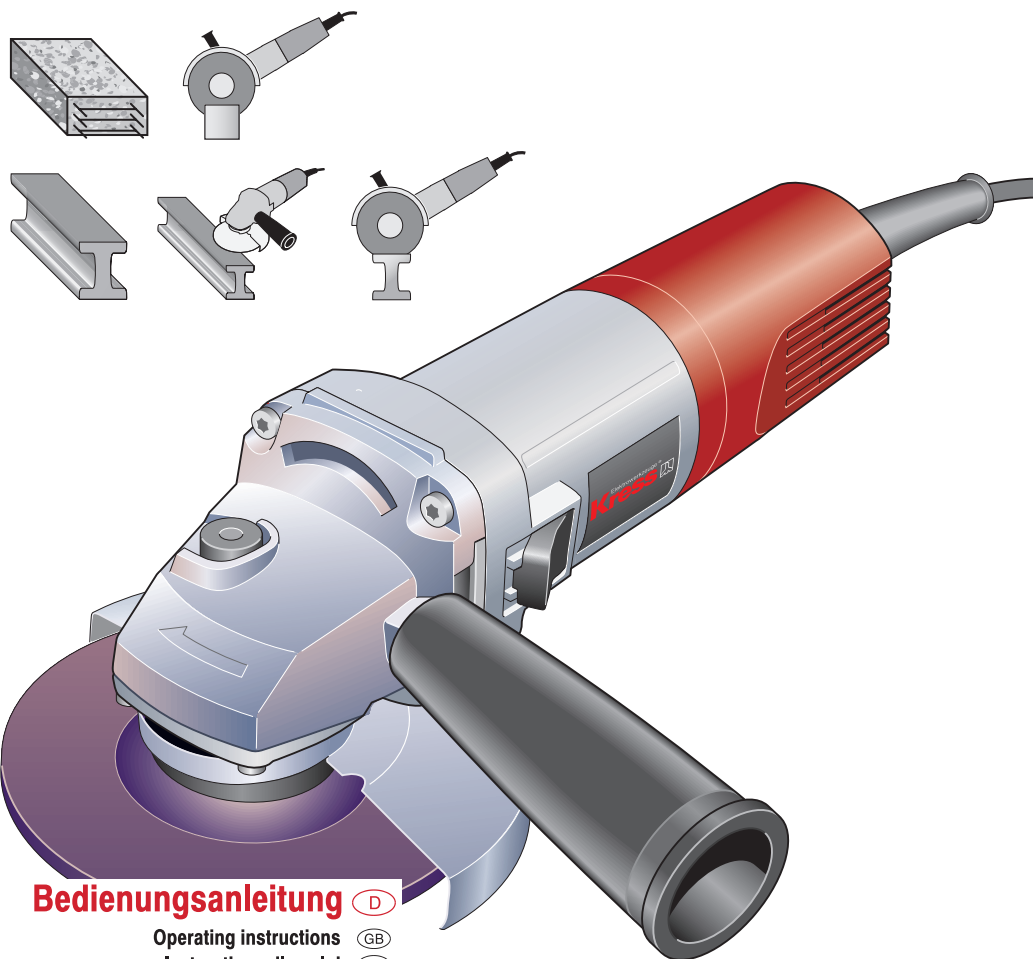

Bedienungsanleitung

- Operating instructions
Instructions d'emploi
Gebruiksaanwijzing
Istruzioni d'uso
Instrucciones de manejo
Bruksanvisning
Betjeningsvejledning
Bruksanvisning
Käyttöohje
Οδηγίες χρήσης
Návod k obsluze
Instrukcja obsługi
Руководство по обслуживанию
Instruções de serviço
Használati utasítás
사용 설명서



34835/0501

Table with 3 columns: Language, Technical data, and values. Includes rows for GB, F, NL, I, E, S, DK, N, FIN, GR, CZ, PL, RUS, P, H, KOR.

Table with 4 columns: Language, Safety instructions, and icons. Includes rows for GB, F, NL, I, E, S, DK, N, FIN, GR, CZ, PL, RUS, P, H, KOR.

Service

D Bundesrepublik Deutschland
KRESS-elektrok GmbH & Co. KG
Elektromotorenfabrik
Abt. Kundendienst / Werk 2
Hechinger Straße 48
D-72406 Bisingen / Zollernalbkreis
Telefon: +49-(0)7476-87450
Telefax: +49-(0)7476-87375
E-mail: tkd@kress-elektrok.de

H Hungaria
MAQYARORSZAG
Csőszer & Co. Kft.
Gubacsi út 28
107 Budapest
Phone: +36 - 280 1020, 280 1000
Telefax: +36 - 280 8329, 280 1008
E-Mail: fischer.hu@matavnet.hu
www.fischerhungary.hu

P Portugal
Sarraipa S.A.
Máquinas e Equipamentos Industriais
Rua das Flores, Carreira d'Água
Zona Industrial da Barosa
PT-2400 Leiria
Phone: +351 - (2)44 - 81 90 60
Telefax: +351 - (2)44 - 81 90 69
E-mail: sarraipa@net.sapo.pt

A Österreich
Elektrotechnik - Elektromaschinenbau
Braunauer Str. 1 C
A-5230 Mattighofen
Telefon: +43-(0)7742-2363
Telefax: +43-(0)7742-4510
E-mail: office@bamberger.at

E Espana
Apolo fijaciones y herramientas s.l.
Garrota Naves 10-22
Polig. Ind. Pla. de la Bruguera
E-08211 Castellar del Vallès (Barcelona)
Telefono: +34 - 93 - 747 33 35
Telefax: +34 - 93 - 747 33 37
E-mail: fijaciones@apolo.es

CZ Czech republic
Fischer International s.r.o.
Prumyslova 1833
CZ-25001 Brandys n/L
Phone: +42 (0)326 - 90 46 01
Telefax: +42 (0)326 - 90 46 00
E-mail: custom.service@cs.cz

CH Schweiz/Suisse
CEKA Elektrowerkzeuge AG + Co. KG
Industriestraße 2
CH-9630 Wattwil
Telefon: +41-(0)71-9874040
Telefax: +41-(0)71-9874041
E-mail: info@ceka.ch

S Sveriget
AB Novum
Mörsaregatan 8
S-25466 Helsingborg
Phone: +46 (0)42 - 15 10 30
Telefax: +46 (0)42 - 16 16 66
E-mail: mail@abnovum.se

PL Polska
Lange Lukaszuk
Byków 25 A
PL-55-095 Mirków
Phone: +48 (0)71 39 80 818
Telefax: +48 (0)71 39 80 819
E-mail: firma@langelukaszuk.pl

GB Great Britain
N & J Tools Ltd.
Westcross Centre, 15 Shield Drive
Brentford TW8 9EX
Phone: +44 (0)208-560 0885
Telefax: +44 (0)208-847 0790
E-mail: njtoolsbrentford@btopenworld.com

DK Danmark
Ryttergaard Vaerktojs A/S
Postbox 118, Rodovrevej 151
DK-2610 Rodovre
Phone: +45 - 36 70 65 55
Telefax: +45 - 36 41 44 72
E-mail: Kress@os.dk

RUS Россия
ДАНГА
Нахимовский проспект 48
Россия 117292 Москва
Телефон: +7 (0)95 - 741-25-17
Телефакс: +7 (0)95 - 125-17-25
E-mail: danga@mmtel.ru

F France
S.A.R.L. Induba
4, Rue du Viaduc - B.P. 87
F-01130 Les Neyrolles
Téléphone: +33-(0)4-74750133
Téléfax: +33-(0)4-74752362
E-mail: induba@online.fr

FIN Suomi
Tecalmit
Hankasaloentie 13, P.O. Box 78
FIN-00391 Helsinki
Phone: +358 (0)9 - 54 77 01
Telefax: +358 (0)9 - 547 17 79
E-mail: jyri.lahti@tecalmit.fi

KOR Korea
Phenix Trading Co., Ltd.
Phenix BLDG. 926-3, Bangbae-Dong,
Seocho-Ku, Seoul 137-843, Korea
Mail: C.P.O. Box 2995 Seoul, Korea
Phone: +82 -2-586-7136, 7137, 7138, 0960
Telefax: +822-586-8948, 598-7634
E-mail: phenix@unitel.co.kr

B NL Belgie/Belgique, Nederland
Present Handel bvba/sprl
Industriezone "Wolfstee"
Toekomstlaan 6
B-2200 Herentals
Telefon: +32-(0)14-257474
Telefax: +32-(0)14-257475
e-mail: info@present.be

N Norge
Ifø Electric AS
P.O.B. 336 Alnabru
Brobekkeveien 115 B
N-0614 Oslo
Phone: +47 - 23 - 37 81 10
Telefax: +47 - 23 - 37 81 20
E-mail: info@ifoelectric.no

RO Romania
PGM Trading s.r.l.
Sector 3, P-Ta Alba Iulia Nr. 5
Bl. 14, SC 1, Et. 2, AP 10
Romania, Bucharest
Telefon: +40 (0)21 323 68 87
Fax: +40 (0)21 322 59 29
E-mail: office@pgm.ro

I Italia
Hodara Utensili S.p.A.
Viale Lombardia, 16
I-20090 Buccinasco (Milano)
Telefono: +39 - 02 - 48 84 25 97
Telefax: +39 - 02 - 48 84 27 75
E-mail: info@hodara.it

G Hellas
D. Nikolaou & Co Ltd.
Leonidoy 6; GR-17343 Athens
Phone: +30 - 210 - 975 37 57
Telefax: +30 - 210 - 973 74 23
E-mail: vnikaolaou@internet.gr

BG Bulgaria
Bratja Petrovi GmbH
Targovska Str. 5
BG-5500 Lovetsch
Phone: +359 - 68 - 60 02 79
Telefax: +359 - 68 - 60 02 79
E-mail: kress@infotel.bg

IS Israel
שרות ע"י כל סניפי הווס סנטר

CE Konformitätserklärung
Wir erklären in alleiniger Verantwortung, dass dieses Produkt mit den folgenden Normen oder normativen Dokumenten übereinstimmt: siehe unten

CE Declaration of conformity
We declare under our sole responsibility that this product is in conformity with the following standards or standardization documents: see below

CE Déclaration de conformité
Nous déclarons sous notre propre responsabilité que ce produit est en conformité avec les normes ou documents normalisés: Voir ci-dessous

CE Konformiteitsverklaring
Wij verklaren op eigen verantwoording, dat dit produkt voldoet aan de volgende normen of normatieve documenten: zie onder

CE Dichiarazione di conformità
Assumendone la piena responsabilità, dichiariamo che il dotto è proconforme alle seguenti normative ed ai relativi documenti: vedere sotto

CE Declaracion de conformidad
Declaramos bajo nuestra sola responsabilidad que este producto está en conformidad con las normas o documentos normalizados siguientes: ver abajo

CE Konformitetsförklaringen
Vi intygar och ansvarar för att denna produkt överensstämmer med följande norm och dokument: se nedan

CE Overensstemmelseserklæring
Vi erklærer under almindeligt ansvar, at dette produkt er i overensstemmelse med følgende normer eller normative dokumenter: se nedenfor

CE Erklæring av konformitet
Vi overtar ansvaret for at dette produktet er i overensstemmelse med følgende standarder eller standarddokumenter: se nede

CE Todistus
Todistamme täten ja vastaame yksin siitä, että tämä tuote en allatueteltujen standardien ja stardoimisasiakirjojen vaatimusten mukainen: katso alla

CE Δήλωση συμμορφότητας
Δηλώνουμε υπευθύνως ότι το προϊόν αυτό είναι κατασκευασμένο σύμφωνα με τους εζής κανονισμούς ή κατασκευαστικές συστάσεις: βλέπε κάτω

EN 50144-2-3, EN 55014-1, EN 55014-2, EN 61000-3-2, EN 61000-3-3
72/23/EWG, 89/336/EWG, 98/37/EG

KRESS-elektrok GmbH + Co. KG, D-72406 Bisingen
Bisingen, im Januar 2005

Alfred Binder,
Entwicklungsleiter

Josef Leins,
Leiter Qualitätssicherung



http://www.kress-elektrok.de
http://spareparts.kress-elektrok.de