

FLEXA®

81-20502-1/-2

126 x 72 x 30cm

Flexa Regal breit
mit 3 Böden
natur:
4048.632
weiss:
4048.626

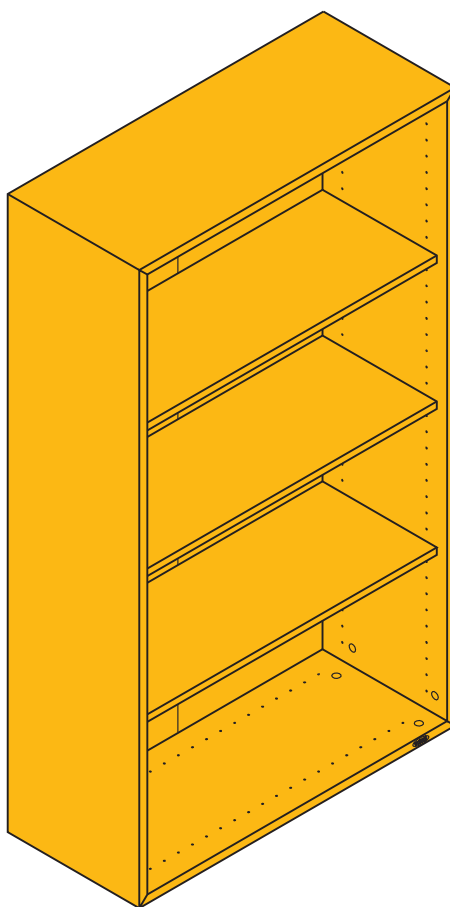

For indoor
domestic use



Danish Design made in Denmark

Monterings- og brugsvejledning

Assembly instructions and
directions for use

Montageanleitung und
Gebrauchsanweisung

Notice de montage et mode
d'emploi

Instrucciones de montaje y uso

Montageinstructie en onderhouds
voorschrift

Istruzioni di montaggio e uso



Møbler fra FLEXA er fremstillet af massivt træ, hvilket betyder at farve-og strukturforskelle er en naturlig del af møblet.

Skulle der mod forventning opstå en reklamation, skal denne blanket udfyldes og returneres til FLEXA forhandleren. Venligst kontroller, at alle dele er komplette, inden montage påbegyndes.



Furniture from FLEXA is produced from solid wood, which means

that colour and structure difference are a natural part of the furniture. However should a complaint occur, this form must be filled and returned to your FLEXA stockist. Please make sure that all parts are complete before you start assembling.



Die FLEXA Produkte werden aus massivem Kiefernholz hergestellt. Farbunterschiede sowie unter-

schiedliche Maserungen sind Naturmerkmale. Sollte es trotzdem Grund zur Reklamation geben, füllen Sie bitte diesen Schein aus und wenden Sie sich an Ihren FLEXA Händler. Kontrollieren Sie vor Montagebeginn den Artikel auf Vollständigkeit und Beschädigungen.

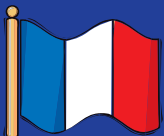

Les meubles FLEXA sont réalisés en pin massif. Certaines différences de teintes ou de structures

peuvent apparaître : elles proviennent de la matière naturelle du bois. Si toutefois vous constatez une anomalie, merci de remplir la fiche ci-jointe et de la retourner à votre revendeur. Veuillez vérifier l'intégralité des pièces avant d'entreprendre le montage.



Los muebles de FLEXA están hechos de pino macizo, por lo cual pueden aparecer pequeñas diferencias en el tono y la estructura

del mueble, formado de manera natural. Si en contra de lo previsto surge una incidencia, hay que rellenar este formulario y devolverlo al distribuidor. Les rogamos controlen que todas las piezas están completas antes de empezar el montaje.



De meubelen van FLEXA zijn gemaakt van massief hout hetgeen betekent dat kleur en structuurverschillen een

natuurlijk onderdeel zijn van de meubelen. Mocht er desondanks een klacht ontstaan, vul dan dit formulier in en lever het in bij uw FLEXA dealer. Controleer of alle benodigde onderdelen aanwezig zijn voordat u begint met monteren.

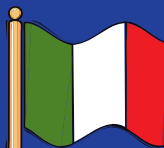

I mobili della FLEXA sono prodotto in legno di pino massiccio, significa che si possono verificarsi piccole nocchie e gradazioni di colore e simili sulla

superficie che fanno parte delle caratteristiche del legno naturale. Comunque per qualsiasi reclamo bisogna riempire il modulo e consegnarlo al Vostro rivenditore. Vi preghiamo di controllare che tutti i pezzi siano intatti prima di cominciare il montaggio.

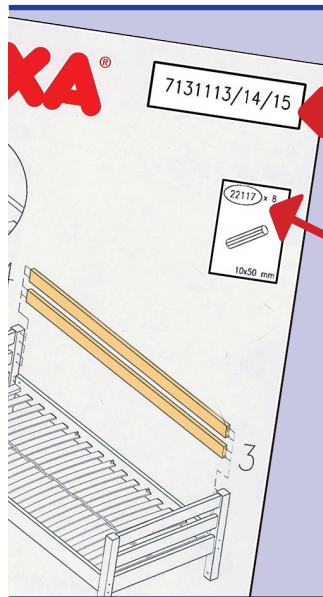

**Model nr. / Model No / Modell Nr. /
Modèle no / No Modelo / Artikel nr. /
Numero Modello**

**Emne nr. / Part / Teile-Nr. /
Pièce réclamée / No. pieza /
Onderdeelnummer / No. pezzo**

Årsag

1

Manglende del / Missing part/
Fehlendes Teil / Pièce manquante /
Falta pieza / Missende delen / Parte
mancante

Reason

Ursache

2

Fejl i træet / Defect in the wood /
Holzfehler / Défaut de bois /
Madera defectuosa / Fout in het
hout / Difetto nel legno

Motif

Motivo

3

Fejlboring / Faulty drilling
Falsche Bohrung / Défaut de
perçage
Taladro erróneo / Verkeerd geboord
Difetto forature





Oorzaak

Motivo

4

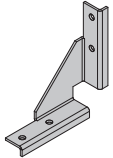
Fejl i lakken / Fault in lacquer
Fehler im Lack / Défaut de finition
Barniz defecto / Fout in de
lakafwerking / Difetto laccatura

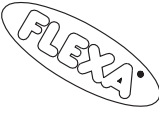
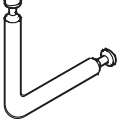
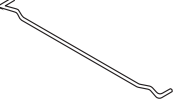

<p>4092-0014 x4</p>  <p>70x70mm</p>	<p>22014 x1</p> 	<p>3933-15012 x16</p>  <p>15x10,5 mm</p>	<p>22032 x8</p>  <p>nr. 0</p>
<p>22702 x16</p>  <p>3x16mm PH</p>	<p>28011 x1</p> 	<p>3934-07088 x8</p>  <p>47x47 mm</p>	<p>22220 x6</p>  <p>192 mm</p>

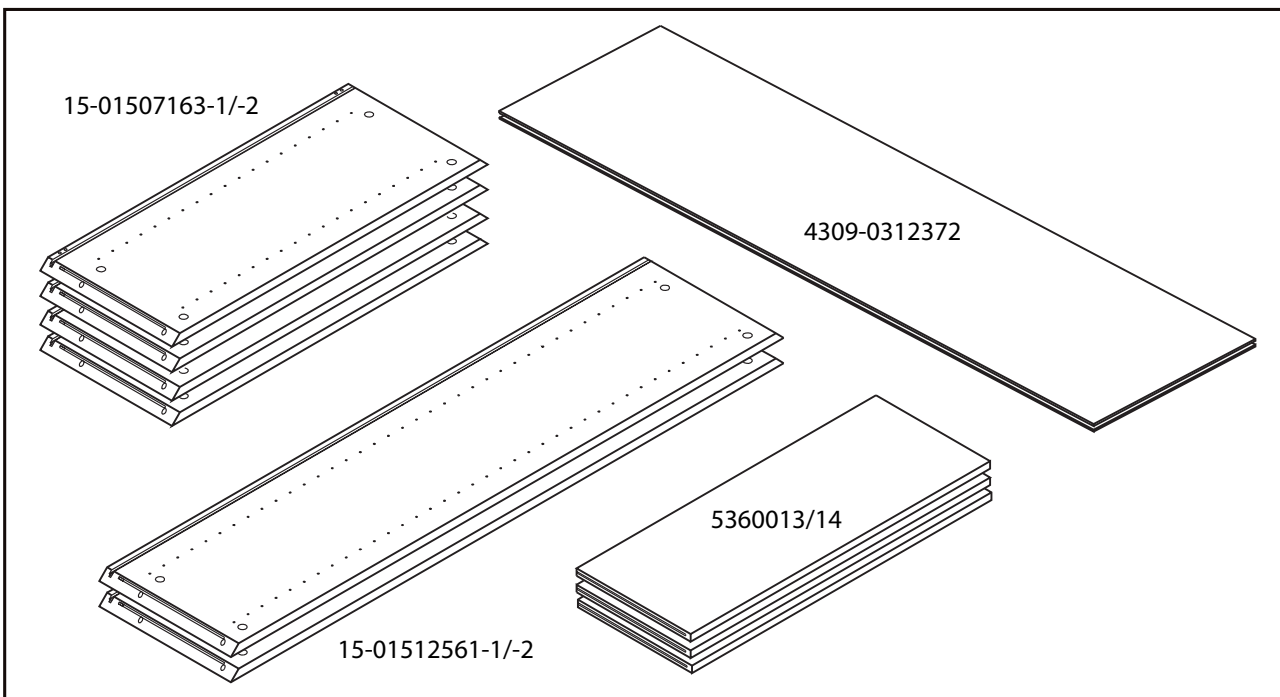
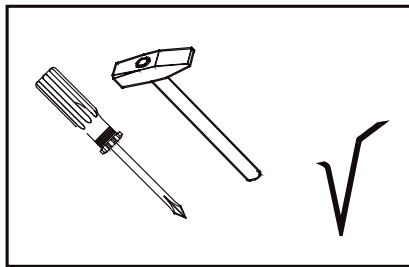

1

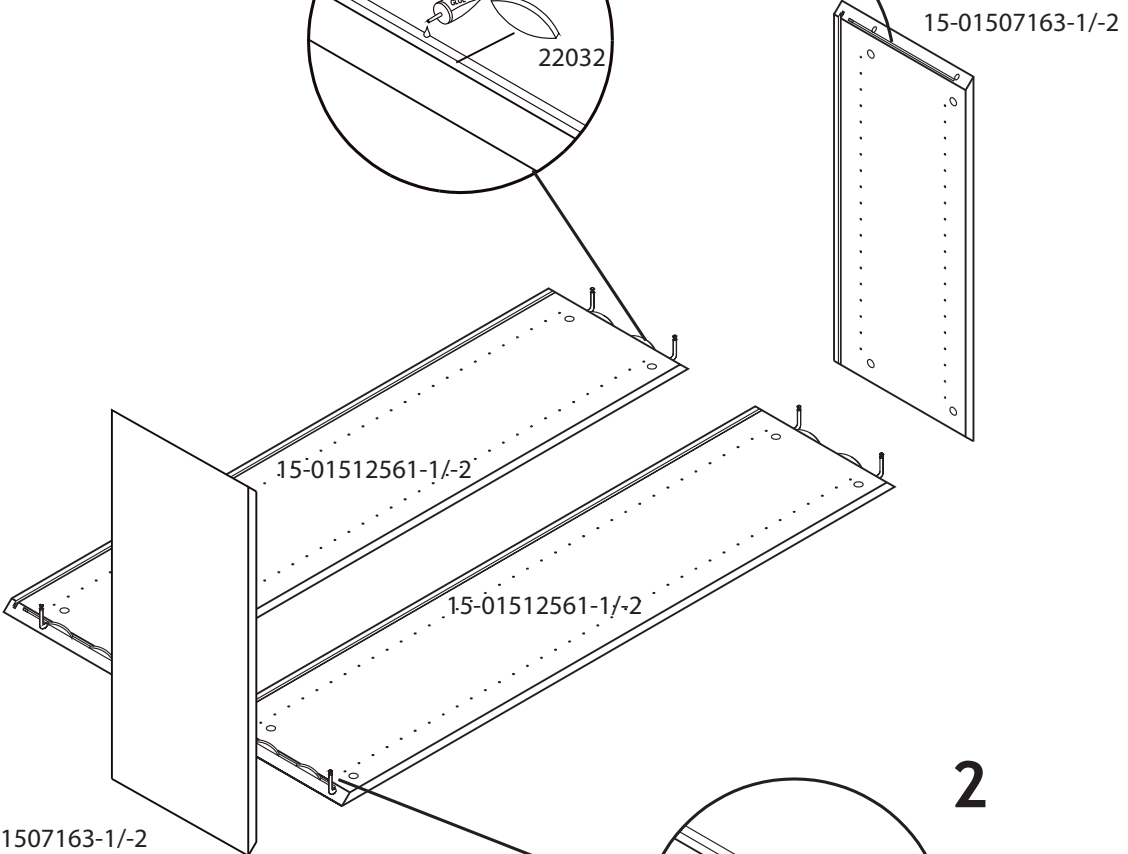
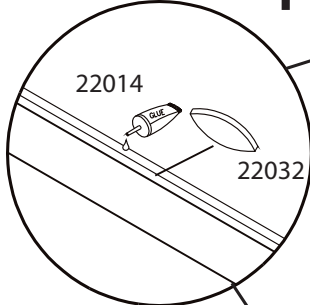

2

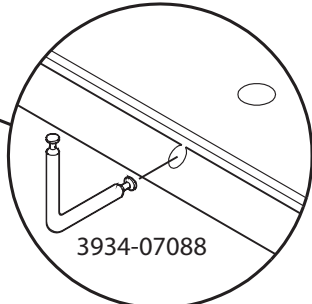

4



15-01512561-1/-2

3



4309-0312372

15-01507163-1/-2

5

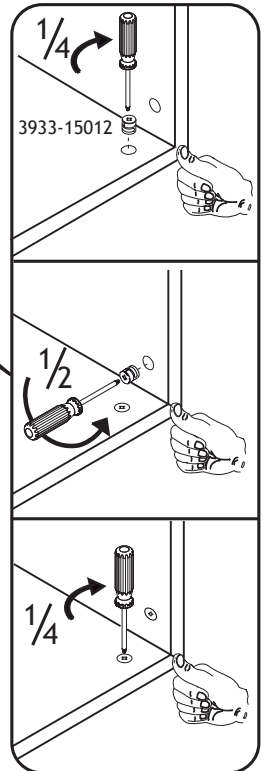

15-01512561-1/-2

15-01507163-1/-2

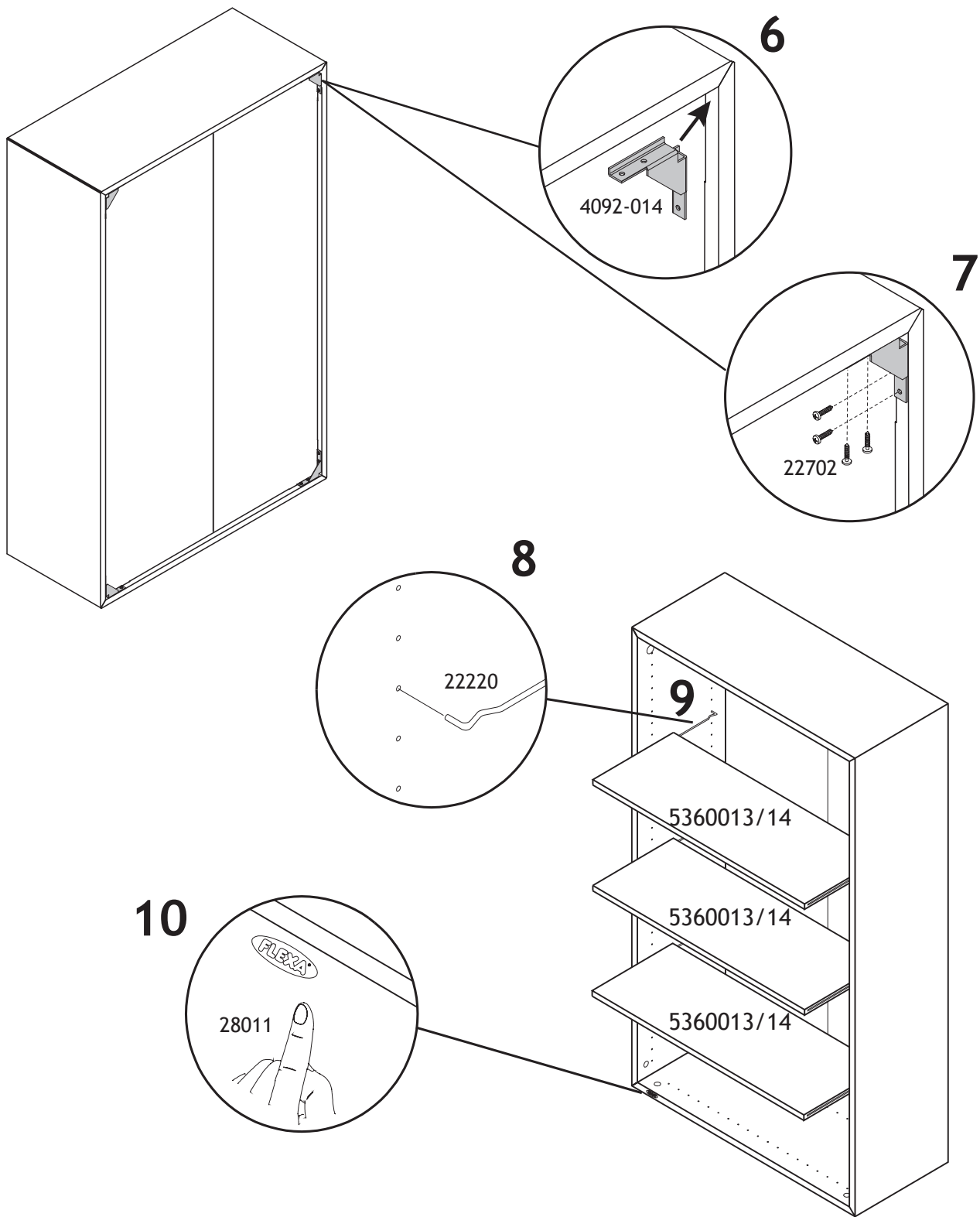

<p>(DK) RÅD OM VEDLIGEHOJDELSE: Tør af med en fugtig klud. Evt. større pletter fjernes med en fugtig svamp med sæbe. Undgå opløsningsmidler. Skruer og bolte efterspændes med jævne mellemrum.</p> <p>MAXIMUM VÆGT PR. HYLDE 15 KG</p>	<p>(GB) MAINTENANCE INSTRUCTIONS: Cleaning with a wet cloth, use a sponge with soap to remove obstinate dirt. Avoid solvents and dilutions. Screws and bolts should from time to time be retightened.</p> <p>MAXIMUM LOAD PER SHELF 15 KG</p>	<p>(D) PFLEGEHINWEIS: Pflege mit einem feuchten Lappen. Für hartnäckigen Schmutz empfehlen wir einen Schwamm mit Seife. Vermeiden Sie Lösungs- und Verdünnungsmittel. Schrauben und Bolzen sollten regelmäßig nachgezogen werden.</p> <p>EINLEGEBODEN/REGAL NICHT ÜBER 15 KG</p>	<p>(F) CONSEILS D'ENTRETIEN: Entretien avec un chiffon humide pour la poussière - les tâches rebelles s'enlèvent avec une éponge légèrement savonneuse. Éviter tous solvants et diluants. Votre lit doit être vérifié périodiquement afin de resserrer les vis.</p> <p>LE POIDS SUPPORTÉ PAR ÉTAGÈRE NE DOIT EXCÉDER 15 KG</p>	<p>(E) CONSEJO PARA LA CONSERVACIÓN: Limpiar con un paño húmedo. Para quitar manchas mas grandes usar una esponja con jabón. Evitar usar productos quimicos. Las herrajes necesitan opretarse a veces.</p> <p>PESO RECOMENDADO POR ESTANTE 15 KG</p>	<p>(NL) ONDERHOUD: Reinigen met een vochtige doek. Hardnekkig vuil verwijderen met een spons en zeep. Vermijd oplos- en verdunningsmiddelen. Schroeven en moeren regelmatig aandraaien.</p> <p>MAXIMUM DRAAGGEWICHT PER SCHAP 15 KG</p>	<p>(I) CONSIGLI PER LA MANUTENZIONE: Pulire con un panno umido, usare una spugna impregnata di sapone per togliere lo sporco persistente. Evitare l'uso di prodotti chimici. Dadi e viti sono, di tanto e tanto, da ri-avvitare.</p> <p>CARICO MASSIMO OGNI SINGOLA MENSOLA 15 KG</p>
---	--	---	---	---	--	--