



Instructions for use

ART 507

Whirlpool Switzerland, www.whirlpool.ch

Bauknecht AG, Industriestrasse 36, 5600 Lenzburg, www.bauknecht.ch

Verkauf	Telefon 0848 801 002	Fax 0848 801 017	verkauf@bauknecht.ch
Kundendienst	Telefon 0848 801 001	Fax 0848 801 003	service@bauknecht.ch
Ersatzteile	Telefon 0848 801 005	Fax 0848 801 004	ersatzteilverkauf@bauknecht.ch

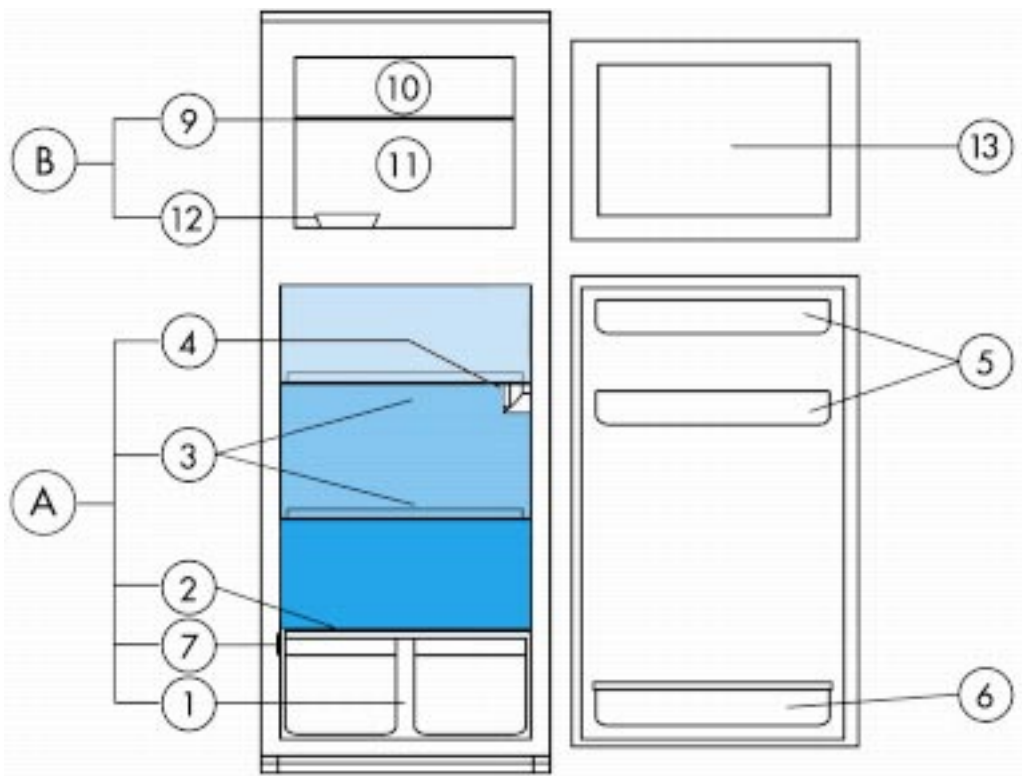

A. Refrigerator compartment

1. Crisper drawers
2. Cover crisper
3. Shelves / shelf area
4. Thermostat control knob/light
5. Door trays
6. Bottle shelf
7. Rating plate (at side of crisper drawer)

- cool zone
- intermediate temperature
- cold zone

B. Freezer compartment ❄️❄️❄️

8. Rack
9. Area for fast freezing of fresh food products
10. Storage area for frozen or deep-frozen food
11. Ice cube tray
12. Freezer compartment inner door panel.

Note: the number of shelves and the design of accessories may vary depending on the model. Shelves and door trays are all removable.

Warning: refrigerator accessories are not dishwasher-resistant.

Controls

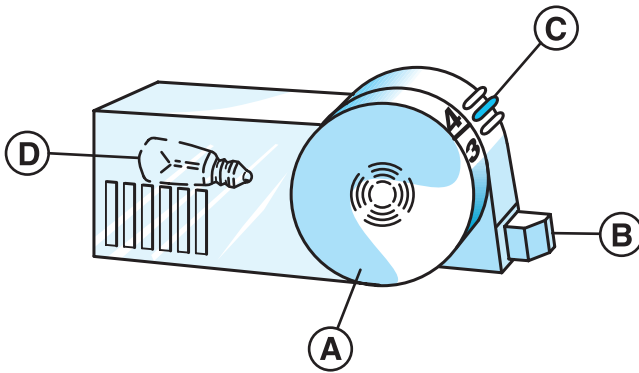

- A. Thermostat knob
- B. Light switch
- C. Thermostat setting index
- D. Bulb (15 W max.)

Thermostat set to ●: refrigerator and lights off
 Thermostat set to **1**: **warmest** internal temperature
 Thermostat set to **7**: **colest** internal temperature

It is advisable to set the thermostat to positions 2-3

Note: external air temperature, the frequency with which the door is opened and the position of the appliance may affect the internal temperature of the refrigerator. Set the thermostat accordingly.

Removing the light

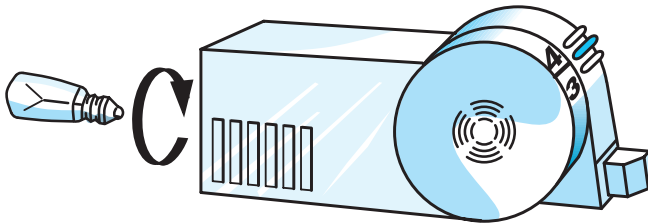

Undo by turning anticlockwise, as shown in the illustration.

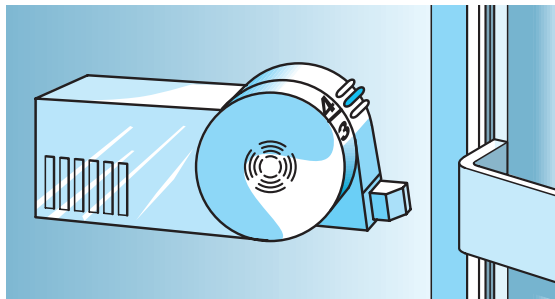

The door tray must be positioned as indicated to operate the interior light button.

CONTENTS

GB

BEFORE USING THE REFRIGERATOR

PAGE 12

SAFEGUARDING THE ENVIRONMENT

PAGE 12

**PRECAUTIONS AND GENERAL
RECOMMENDATIONS**

PAGE 13

**HOW TO OPERATE THE REFRIGERATOR
COMPARTMENT**

PAGE 14

**HOW TO OPERATE THE FREEZER
COMPARTMENT**

PAGE 15

**HOW TO DEFROST AND CLEAN THE FREEZER
COMPARTMENT**

PAGE 16

**HOW TO CLEAN THE REFRIGERATOR
COMPARTMENT**

PAGE 16

CARE AND MAINTENANCE

PAGE 17

TROUBLESHOOTING GUIDE

PAGE 17

AFTER-SALES SERVICE

PAGE 18

INSTALLATION

PAGE 18

ELECTRICAL CONNECTION

PAGE 19

BEFORE USING THE REFRIGERATOR

Your new appliance is exclusively for domestic use.

The **freezer compartment** ❄️❄️❄️ can be used for freezing fresh and cooked food, making ice cubes, and storing frozen and deep-frozen food; **defrosting is a manual procedure**.

The **refrigerator compartment**, which has an **automatic defrost feature**, is used for the storage of fresh food and beverages.

To get the most out of your new appliance, read the user handbook thoroughly. The handbook contains a description of the appliance and useful tips for storing food.

Keep this handbook for future consultation.

1. After unpacking the appliance, make sure that the door shuts properly. Any damage must be reported to your dealer within 24 hours after delivery of the appliance.
2. **Wait at least two hours without moving the appliance before switching on. This will give the refrigerant circuit time to settle and operate efficiently.**
3. Installation of the appliance and electrical connections must be carried out by a qualified electrician, in accordance with the manufacturer's instructions and local regulations.

SAFEGUARDING THE ENVIRONMENT

1. Packing ♻️

The packaging material is entirely recyclable, and marked with the recycling symbol. Follow local regulations for scrapping.

Keep the packaging materials (plastic bags, polystyrene parts, etc.) out of reach of children, as they are potentially dangerous.

2. Appliance

The appliance is made using recyclable materials. Dispose of the appliance in conformity with local environmental regulations.

Make the appliance unusable by cutting off the power cord. The appliance must be delivered to an authorised collection centre for the recovery of refrigerant gas.

Information:

This appliance does not contain CFCs (replaced with R134a) or HFCs (replaced with R600a - Isobutane). For more information, refer to the identification data plate affixed to the appliance.



PRECAUTIONS AND GENERAL RECOMMENDATIONS

- Use the **refrigerator compartment** only for storing fresh food and beverages and use the **freezer compartment** only for storing frozen food, freezing fresh food and making ice cubes.
- Do not cover or obstruct the air vents of the appliance.
- Do not store liquids in glass containers in the freezer compartment - danger of bursting.
- Do not eat ice cubes or ice lollies immediately after taking them out of the freezer compartment - risk of "cold" burns.
- Do not allow children to play or hide inside the appliance - risk of becoming trapped and suffocating.
- **Before servicing or cleaning the appliance, unplug it from the mains or disconnect the electrical power supply.**
- The power cable may only be replaced by an authorised person.

Declaration of conformity

- This appliance is intended to come into contact with foodstuffs and conforms to D.L. 108 of 25.01.1992 (European Directive 89/109/EEC).

Appliances with Isobutane (R600a)

Isobutane is a natural gas having low environmental impact. Caution is required, however, since isobutane is flammable. Therefore, it is essential to ensure that refrigerant pipelines are not damaged.

HOW TO OPERATE THE REFRIGERATOR COMPARTMENT

This appliance is a refrigerator with a * ** ** star freezer compartment.

Defrosting of the refrigerator compartment is completely automatic.

The refrigerator can operate at ambient temperature between +10°C and +38°C. Optimal performance is obtained at temperatures between +16°C and +32°C.

Switching on the refrigerator for the first time

Insert the plug into the mains socket.

The thermostat is used to adjust the temperature of both compartments: refrigerator and freezer.

How to adjust the temperature of the compartments:

1. For correct operation and optimum storage of food, **follow instructions given in the enclosed product sheet for thermostat adjustment.**
2. To adjust the temperature in the refrigerator compartment, turn the thermostat control knob:
 - **lowest** numbers **1-2/MIN** for the **LEAST COLD** internal temperatures;
 - **highest** numbers **5-7/MAX** for the **COLDEST** internal temperatures.

Thermostat set to ●: no operation, no light.

Note:

The ambient air temperature, frequency of door opening and the position of the appliance can affect internal temperatures. These factors must be taken into account when setting the thermostat.

How to use the refrigerator compartment

Position the food as illustrated in the figure.

- A Cooked food
- B Fish, meat
- C Fruit and vegetables
- D Bottles
- E Eggs
- F Butter, cheese and dairy products

Notes:

- The space between the shelves and the rear wall of the refrigerator compartment must be unobstructed to allow circulation of air.
- Do not place food in direct contact with the rear wall of the refrigerator compartment.
- Do not place hot food in the refrigerator or freezer.
- Store liquids in closed containers.

- Storing vegetables with a high water content can result in condensation in the crisper drawer: this will not affect the correct operation of the appliance.



HOW TO OPERATE THE FREEZER COMPARTMENT

The freezer is a **★☆☆** star compartment.

This compartment can be used to store frozen foods for the period of time indicated on packaging. The freezer can also be used to freeze fresh food by positioning it on the rack; place frozen food in the lower part of the compartment so that there is no contact with fresh food that has yet to be frozen.

The quantity of fresh food that can be frozen in 24 hours is shown on the rating plate.

Important:

Before freezing, wrap and seal fresh food in:

- aluminium foil, cling film, air and water-tight plastic bags, polythene containers with lids or freezer containers suitable for freezing fresh food.
- In the event of a power cut, the freezer compartment will maintain a sufficiently low temperature for food storage. However, it is advisable to avoid opening the compartment door during such periods.

Important:

The table alongside shows the recommended maximum storage time for frozen fresh foods.

When purchasing frozen food products:

- Ensure that the packaging is not damaged (frozen food in damaged packaging may have deteriorated). If the package is swollen or has damp patches, it may not have been stored under optimal conditions and defrosting may have already begun.
- When shopping, leave frozen food purchases until last and transport the products in a thermally insulated cool bag.
- Place the items in the freezer compartment as soon as you get home.
- If food has defrosted even partially, do not re-freeze it. Consume within 24 hours.
- Avoid, or reduce temperature variations to the minimum. Respect the best-before date on the package.
- Always observe the storage information on the package.

Making ice cubes

- Fill the ice cube tray 3/4 with water and place it at the bottom of the freezer compartment. Do not use sharp or pointed instruments to detach the tray if it is stuck to the compartment bottom.



MONTHS

FOOD

1-3



4-7



8-12

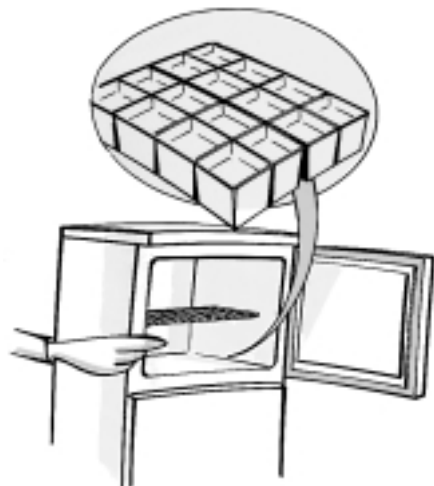

HOW TO DEFROST AND CLEAN THE FREEZER COMPARTMENT

Defrost the freezer compartment once or twice a year, or when the ice on the walls reaches a thickness of about 3 mm. If possible, carry out defrosting when the compartment is nearly empty.

- Remove the food from the low temperature compartment, wrap in a newspaper and group together in a cool place or in a portable cooler.
- **Disconnect the appliance from the mains power supply.**
- Leave the door open to allow the frost to melt.
- Remove the defrost water from the compartment bottom.
- Clean the interior with a sponge dampened in lukewarm water and neutral detergent. **Do not use abrasive products.**
- Rinse the interior and dry thoroughly.

Note: Do not use sharp or pointed metal instruments to scrape off ice; do not heat the freezer compartment artificially.



HOW TO CLEAN THE REFRIGERATOR COMPARTMENT

Periodically clean the inside of the refrigerator compartment.

Defrosting of the refrigerator compartment is completely automatic.

Droplets of water on the rear wall of the refrigerator compartment indicate that the periodic automatic defrost cycle is in progress. The defrost water is automatically routed to a drain outlet and into a container from which it evaporates.

Clean the defrost water drain outlet regularly using the tool supplied with the appliance in order to ensure defrost water is removed correctly.

Before carrying out any cleaning operations, unplug the appliance.

- Use a sponge dampened in lukewarm water and/or neutral detergent.
- Rinse the interior and dry with a soft cloth. **Do not use abrasive products.**



CARE AND MAINTENANCE

For built-in appliances

- Periodically clean air vents with a vacuum cleaner or a brush (see **figure A**).
- Clean the outside using a soft cloth.

Freestanding appliances

- Periodically clean the condenser at the rear of the appliance with a vacuum cleaner or a brush (see **figure B**).

Prolonged disuse

1. Empty the refrigerator and freezer compartments.
2. Disconnect the appliance from the mains power supply.
3. Defrost the freezer compartment, and clean and dry both compartments.
4. Leave the doors open to prevent formation of unpleasant odours.



TROUBLESHOOTING GUIDE

1. The appliance is not working.

- Is there a power failure?
- Is the plug properly inserted in the mains socket?
- Is the double-pole switch on?
- Has the fuse blown?
- Is the power cord in perfect condition?
- Is the thermostat set to ● (Stop)?

2. Temperature inside the compartments is not low enough.

- Is the door shut properly?
- Is the appliance installed near a heat source?
- Is the thermostat setting correct?
- Are the air circulation grilles blocked?

3. Temperature inside the refrigerator compartment is too low.

- Is the thermostat setting correct?

4. Water collects at the bottom of the refrigerator compartment.

- Is the defrost water drain blocked?

5. The inside light is not working.

Perform the checks for problem 1, then:

- Disconnect the appliance from the mains power supply. To inspect the bulb, refer to the instructions and illustration on the attached table.
- Check the bulb and, if necessary, replace it with one of the same type. Replace using maximum 15W bulb.

6. Excessive frost build-up in the freezer compartment.

- Is the door shut properly?
- Is food obstructing proper door closure?

Notes:

- **The front edge of the appliance may be hot. This prevents the formation of condensation and is not a defect.**
- **Gurgling and hissing noises due to expansion in the refrigerant circuit are normal.**

AFTER-SALES SERVICE



Before contacting After-Sales Service:

1. See if you can solve the problem yourself with the help of the "Troubleshooting guide".
2. Switch the appliance on again to see if the problem has been solved.
If it has not, disconnect the appliance from the power supply and wait for about an hour before switching on again.
3. If the problem persists after this course of action, contact After-sales Service.
Specify:
 - the nature of the problem
 - the model
 - the Service number (the number after the word SERVICE on the data plate on the inside of the appliance)
 - your full address
 - your telephone number and area code

SERVICE 0000 000 00000



Note:

The direction of door opening can be changed. If this operation is performed by After-sales Service it is not covered by the warranty.

INSTALLATION

- Install the appliance away from heat sources.
- Install the appliance in a dry, well-ventilated place.
- Do not obstruct the top and bottom vent zones.
- Clean the inside (see "How to clean the refrigerator compartment").
- Fit the accessories supplied.

Electrical connection

- **Electrical connections must be made in accordance with local regulations.**
- Voltage and power consumption are indicated on the rating plate (at the side of the crispers).

Freestanding appliances (not built-in)

- Fit the spacers (if supplied) on the rear of the condenser positioned at the back of the appliance (see figure).
- To optimize appliance efficiency, leave a 5 cm gap above the appliance and make sure that adjacent kitchen units are sufficiently distanced to allow air circulation.
- Ensure that the appliance is level, using the front adjustment feet if necessary.

- **Regulations require that the appliance is earthed. The manufacturer declines all liability for injury to persons or animals and for damage to property resulting from failure to observe the above procedures and reminders.**
- If the plug and socket are not of the same type, have the socket replaced by a qualified electrician.
- Do not use extension leads or adaptors.

Disconnecting the appliance

It must be possible to disconnect the appliance by unplugging it or by means of a two-pole switch fitted upline of the socket.

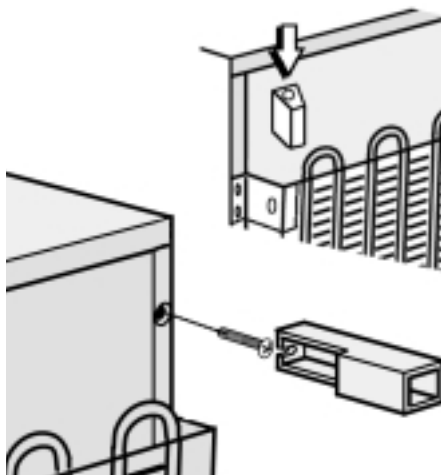

ELECTRICAL CONNECTION

For Great Britain only

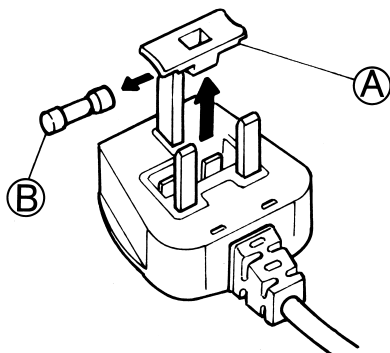

The wires in the mains lead are coloured in accordance with the following code:

BLUE - "NEUTRAL" ("N")

BROWN - "LIVE" ("L")

GREEN AND YELLOW - "EARTH" ("E")

1. The GREEN AND YELLOW wire must be connected to the terminal in the plug which is marked with the letter "E" or by the Earth symbol \perp or coloured green or green and yellow.
2. The BLUE wire must be connected to the terminal which is marked with the letter "N" or coloured black.
3. The BROWN wire must be connected to the terminal which is marked with the letter "L" or coloured red.

Warning - this appliance must be earthed

Fuse replacement

If the mains lead of this appliance is fitted with a BS 1363A 13amp fused plug, to change a fuse in this type of plug use an A.S.T.A. approved fuse to BS 1362 type and proceed as follows:

1. Remove the fuse cover (A) and fuse (B).
2. Fit replacement 13A fuse into fuse cover.
3. Refit both into plug.

Important:

The fuse cover must be refitted when changing a fuse and if the fuse cover is lost the plug must not be used until a correct replacement is fitted.

Correct replacement are identified by the colour insert or the colour embossed in words on the base of the plug.

Replacement fuse covers are available from your local electrical store.

Connection to a rewirable plug

If the fitted plug is not suitable for your socket outlet, then it should be cut off and disposed of in order to avoid a possible shock hazard should it be inserted into a 13A socket elsewhere.

A suitable alternative plug should then be fitted to the cable.

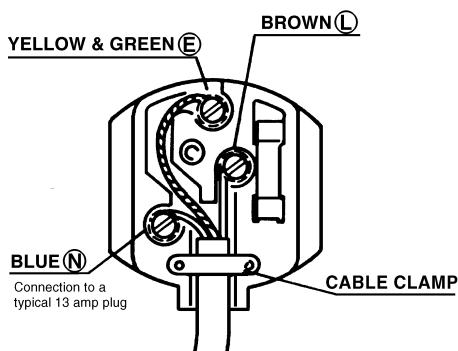

For the Republic of Ireland only

- The information given in respect of Great Britain will frequently apply, but a third type of plug and socket is also used, the 2-pin, side earth type. In this case, the wire which is coloured GREEN AND YELLOW must be connected to the EARTH contact, and the two wires to the two pins, irrespective of colour. The supply to the socket must be fitted with a 16 amp fuse.