

Montageanleitung

- D -

Vorwort

**Sehr geehrte Kundin, sehr geehrter Kunde,
danke, daß Sie sich für unsere Massivholzsaua entschieden haben.**

Lesen Sie diese Anleitung vor dem Aufbau bitte vollständig durch, um Montagefehler oder Beschädigungen zu vermeiden.

WICHTIG !

Prüfen Sie bitte sofort anhand der Packliste, ob die Sauna vollständig und unbeschädigt bei Ihnen angekommen ist.

Bitte vernichten Sie die Packliste erst nach Ablauf der Garantiezeit. Diese Liste dient Ihnen zur Kontrolle auf Vollständigkeit der Einzelteile und ist mit dem Kaufbeleg aufzubewahren. Eventuelle Beanstandungen können mit Hilfe dieser Liste problemlos behoben werden. Die Pos.-Nummern der Packliste stimmen nicht mit den Pos.-Nummern folgender Montageanleitung überein.

Wir empfehlen Ihnen die Montage mit 2 Personen durchzuführen.

Zur Verhütung von Unfällen ist zu vermeiden, daß sich Kinder während der Montage in unmittelbarer Nähe befinden. Weiterentwicklungen im Sinne des technischen Fortschritts behalten wir uns vor. So können geringfügige Abweichungen in den Darstellungen entstehen.

Verpackungsmaterial nicht einfach wegwerfen! Papier-, Pappe- und Wellpappeverpackungen, sowie Kunststoffverpackungsteile sollten in die entsprechenden Sammelbehälter gegeben werden.

Werkstoff Holz

Die Wandelemente bestehen aus sorgfältig ausgesuchtem, nordischen Fichtenholz, die Inneneinrichtung aus einem Spezialholz mit geringer Wärmeleitfähigkeit. Gesunde Äste, leichte Verfärbungen und kleine Risse sind für Holz charakteristisch, verleihen der Kabine sein natürliches Aussehen und sind kein Reklamationsgrund.

Vor der Montage

Für das Aufstellen der Kabine wird eine **Mindestraumhöhe von 220 cm** benötigt. Der Wandabstand sollte mindestens 5 cm betragen.

Der Fußboden muß eben und waagrecht sein, da es sonst zu Funktionsstörungen kommen kann.

Am besten eignet sich ein trockener, gut belüftbarer Raum zur Nutzung Ihrer Kabine.

Ein Stein- oder Fliesenboden erweist sich als praktische und zugleich attraktive Fußbodenvariante.

Tipps zur Sicherheit

Legen Sie keine Gegenstände auf dem Saunaofen ab. - **BRANDGEFAHR !**

Vergewissern Sie sich bereits vor Beginn der Heizphase, daß sich keine brennbaren Gegenstände in der Nähe des Ofens befinden.

Verwenden Sie Sauna - Aufgußkonzentrate nur in verdünnter Form. Hinweise über die richtige Handhabung finden Sie auf den Behältern.

Verwenden Sie keine chemischen Klebstoffe im Inneren der Sauna, sondern allenfalls Holzleim.

Nach Nutzung der Sauna lassen Sie diese bei geöffneter Tür auskühlen. Sorgen Sie stets für eine gute Durchlüftung des Raumes, in dem sich die Sauna befindet.

Pflegehinweise

Um lange Freude an der Kabine zu haben, sollte diese regelmäßig gereinigt werden.

Das unübertroffen milde und bekömmliche Saunaklima wird durch die natürliche Diffusion und Speicherfähigkeit des Massivholzes erreicht.

Daher darf keine Oberflächenbehandlung der Holzteile erfolgen.

Bei längerer Nichtbenutzung empfehlen wir, die Kabine mindestens einmal im Monat eine halbe Stunde aufzuheizen. Damit wird eine unerwünschte Feuchtigkeitsaufnahme vermieden.

Geringer Harzausfluß an der Holzoberfläche ist unvermeidbar. Die trockenen Harzrückstände können mit feinem Schleifpapier entfernt werden.

Elektroinstallation

Die Elektroinstallation darf nur von einem zugelassenen Elektrofachmann unter Beachtung der VDE- und EVU-Richtlinien ausgeführt werden.

Hinweise zur Montage des Saunaofens und des Steuergerätes entnehmen Sie bitte den dort beiliegenden Montageanleitungen.

Spezielle Hinweise

Stecken Sie die Wandbohlen – mit der Feder nach oben – zusammen. Gegebenenfalls helfen Sie mit einem Gummihammer nach, wobei das Montageholz eine Beschädigung der Feder verhindert.

Die Montagehölzer befinden sich im Frontwandpaket der Sauna.

Um die Rechtwinkligkeit zu prüfen, messen Sie die Diagonalen und korrigieren solange, bis Sie gleiche Werte erhalten.

Um dem Absenken der Glastür vorzubeugen, ziehen Sie die Imbusschraube der Beschläge fest an.

Bitte bohren Sie alle Schraubverbindungen vor, um Beschädigungen an den Holzteilen zu vermeiden! Folgendes Zeichen macht Sie während der Anleitung nochmals darauf aufmerksam:

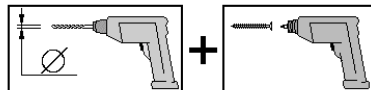

Elektrische Bauteile dürfen nur von einem autorisierten Elektriker angeschlossen werden.

Werkzeug

Folgendes Werkzeug sollten Sie vor Beginn der Montage zurecht gelegt haben.

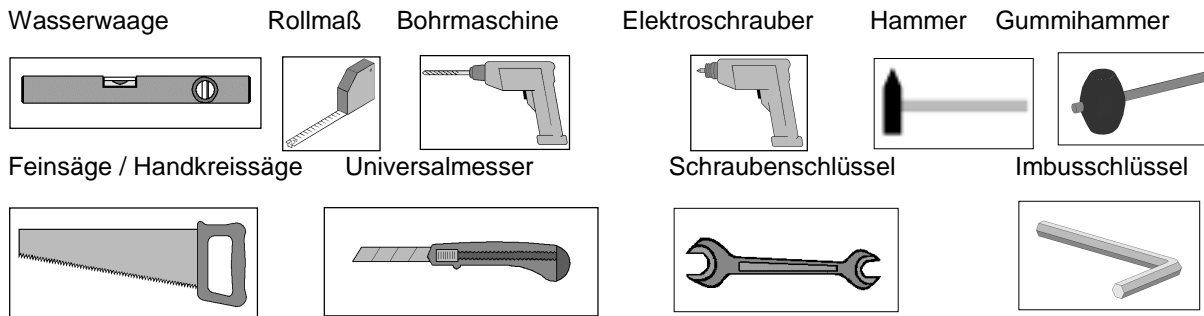

Abkürzungen / Symbole:

- cm - Zentimeter
- mm - Millimeter
- ca. - circa



Avant-propos

Chère Cliente, cher Client

Nous vous remercions d'avoir choisi notre produit.

Lisez entièrement la présente notice avant de procéder à l'assemblage afin d'éviter les erreurs et les dommages.

IMPORTANT !

Veillez vérifier immédiatement, à l'aide de la liste des pièces, si le produit est arrivé complet et en bon état.

Ne détruisez la liste des pièces qu'une fois la garantie écoulee. Cette liste vous permet de vérifier si les pièces détachées sont complètes et doit être conservée avec le justificatif d'achat. Elle vous permettra de faire valoir aisément d'éventuelles réclamations. Les numéros de pos. de la liste des pièces ne sont pas identiques aux numéros de pos. de la présente notice de montage.

Nous vous recommandons d'effectuer le montage à 2 personnes.

Afin de prévenir tout accident, éviter la présence d'enfants à proximité durant le montage.

Nous nous réservons le droit d'apporter aux produits des modifications dans le cadre de l'évolution technique.

De légères différences sont par conséquent possibles par rapport aux illustrations.

Ne pas jeter simplement le matériel d'emballage! Les emballages en papier, carton et carton ondulé doivent être déposés dans le container de tri correspondant.

Consignes spécifiques

Le bois

Les éléments constitutifs des parois se composent de sapin nordique soigneusement sélectionné et l'équipement intérieur d'un bois spécial à faible conductibilité thermique. Les noeuds robustes, les légères décolorations et les petites fissures sont typiques du bois, confèrent aux cabines leur aspect naturel et ne constituent pas un motif de réclamation.

Avant le montage

L'installation de la cabine nécessite une **hauteur sous plafond minimale de 220 cm**. La distance aux murs doit être d'au moins 5 cm.

Le sol doit être plan et horizontal sous peine de risques de dysfonctionnement.

La cabine sera utilisée au mieux dans un local sec et bien aéré.

Les sols en pierre ou en carrelage sont tout à la fois pratiques et esthétiques.

Conseils de sécurité

Ne déposez pas d'objets sur le four du sauna. - **DANGER D'INCENDIE !**

Assurez-vous, dès le début de la phase de chauffe, qu'aucun objet inflammable ne se trouve à proximité du four.

N'utilisez les concentrés pour sauna que sous forme diluée. Les informations nécessaires pour leur bonne utilisation figurent sur les récipients.

N'utilisez pas de colles chimiques à l'intérieur du sauna mais tout au plus de la colle à bois.

Après l'utilisation, laissez le sauna refroidir avec la porte ouverte. La pièce dans laquelle se trouve le sauna doit toujours être bien aérée.

La plaque d'information Pos. 45 doit être fixée à un endroit bien visible à proximité du four du sauna.

Entretien

Pour que vous puissiez profiter longtemps de la cabine, celle-ci doit être nettoyée régulièrement.

Le climat incomparablement doux et sain du sauna est obtenu par la diffusion naturelle et la capacité d'accumulation du bois massif.

Les pièces en bois ne doivent par conséquent faire l'objet d'aucun traitement de surface.

En cas de non utilisation prolongée, nous recommandons de chauffer la cabine au moins une fois par mois pendant une demi heure pour éviter toute absorption indésirable d'humidité.

La sécrétion d'une faible quantité de résine à la surface du bois est inévitable. Les résidus de résine secs peuvent être retirés avec du papier abrasif fin.

Installation électrique

L'installation électrique doit être effectuée uniquement par un électricien agréé, en respect des normes de l'union des électriciens allemands VDE et de l'entreprise de fourniture d'électricité.

Pour les informations relatives au montage du four du sauna et de l'unité de commande, veuillez vous référer aux notices de montage correspondantes.

Consignes spécifiques

Assemblez les madriers des parois, ressort vers le haut. Le cas échéant, aidez-vous d'un maillet en caoutchouc, la pièce de montage évitant d'endommager le ressort.

Les pièces de montage se trouvent dans le paquet de la paroi avant de la maison.

Pour vérifier la perpendicularité, mesurez les diagonales et rectifiez jusqu'à obtenir des valeurs identiques.

Afin de prévenir l'affaissement de la porte en verre, vissez fortement la vis à six pans creux des ferrures.

Pré-percez tous les assemblages vissés afin d'éviter d'endommager les éléments en bois!

Ceci vous est rappelé par le symbole suivant dans la notice:

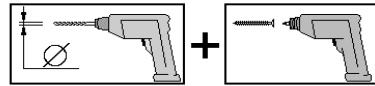

Clauses de garantie

Votre cabine a été soumise à une vérification approfondie et à un contrôle final avant de quitter notre usine.

Au cours de la période de garantie, les pièces défectueuses sont remplacées gratuitement. Les coûts liés au remplacement ne sont pas couverts par la garantie.

L'original de la liste des pièces et l'original du justificatif d'achat sont nécessaires pour faire valoir tous droits relatifs à la garantie.

La garantie ne couvre pas les vices dus à:

- un support non conforme
- un montage non conforme à nos instructions
- l'emploi de la force
- des modifications apportées à la cabine
- un manque d'entretien en vue du maintien de la qualité du bois (voir les instructions d'entretien)

Les autres droits et dommages secondaires n'entrent pas dans le cadre des clauses de garantie.

Le raccordement des composants électriques doit être effectué uniquement par un électricien agréé.

Les composants électriques sont garantis 1 an. En cas de recours à la garantie, la facture de l'électricien agréé qui a procédé au raccordement des composants doit être produite.

Pour le montage, nous vous recommandons de préparer les outils suivants.

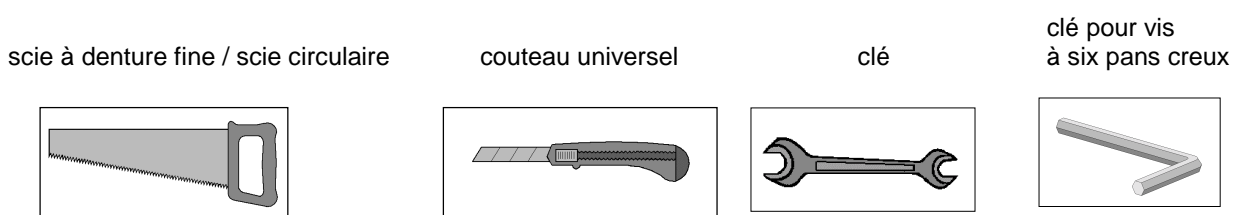
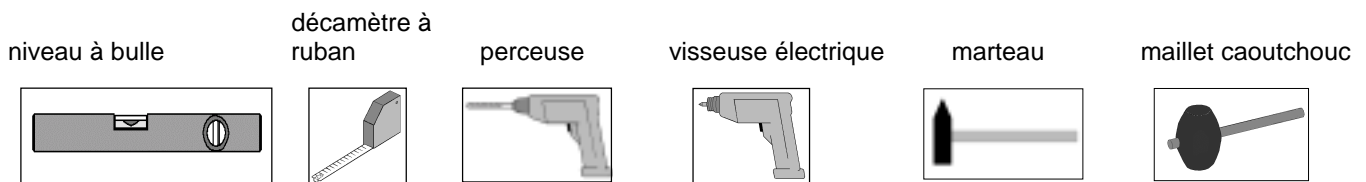

Abréviations / Symboles :

- cm - centimètres
mm - millimètres
ca. - environ / env.

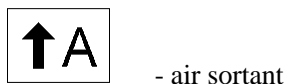
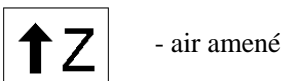

Prefazione

Egregi clienti,

ci congratuliamo con voi per avere scelto questo prodotto.

Prima del montaggio leggete con cura le presenti istruzioni al fine di evitare errori di montaggio o danni.

IMPORTANTE !

Controllate subito con l'ausilio della lista di imballaggio che il prodotto sia stato fornito completo e senza danni.

Vi preghiamo di conservare la lista di imballaggio sino alla scadenza del periodo di garanzia. Questa lista serve per controllare la completezza della fornitura e deve essere conservata insieme allo scontrino. Con l'ausilio della lista è possibile risolvere eventuali reclami. I numeri di posizione della lista di imballaggio non corrispondono con i numeri di posizione delle seguenti istruzioni di montaggio.

Raccomandiamo di eseguire il montaggio in 2 persone.

Per scongiurare eventuali incidenti tenere lontano i bambini dal luogo di montaggio.

Ci riserviamo di apportare modifiche ai fini del progresso tecnologico. Per tale motivo è possibile che nelle rappresentazioni vengano a crearsi lievi differenze.

Non gettare via il materiale di imballaggio! La carta, il cartone normale e ondulato e gli imballaggi in plastica devono essere smaltiti negli appositi contenitori di raccolta.

Indicazioni speciali

Il legno come materiale

Gli elementi delle pareti sono composti da ricercato legno di abete rosso del nord, i componenti interni da un legno speciale a bassa conduttività termica. Ramificazioni sane, leggere irregolarità cromatiche e piccole crepe sono caratteristiche per il legno e donano alla cabina un aspetto naturale; per tale motivo esse non possono essere motivo di reclamo.

Prima del montaggio

Per il montaggio della cabina è necessario che la stanza disponga di **un'altezza minima di 220 cm**. La distanza delle pareti deve essere di almeno 5 cm.

Il pavimento deve essere piano e orizzontale, al fine di evitare successive irregolarità di funzionamento.

Il posto migliore per il montaggio della cabina è una stanza asciutta e con la possibilità di una buona ventilazione.

Un pavimento in pietra o in mattonelle può essere un'alternativa pratica e allo stesso tempo elegante.

Suggerimenti per la sicurezza

Non appoggiate nessun oggetto sul forno della sauna. - **PERICOLO DI INCENDIO !**

Assicuratevi già prima di iniziare a riscaldare che nelle vicinanze del forno non si trovino oggetti infiammabili.

Utilizzate esclusivamente concentrati per sauna diluiti. Delle indicazioni sull'uso corretto sono riportate sui contenitori.

All'interno della sauna non utilizzare collanti chimici, al massimo collante per legno.

Dopo aver usato la sauna lasciatela raffreddare a porta aperta. Fate in modo di aerare bene anche la stanza in cui si trova la sauna.

Il cartello pos. 45 deve essere applicato in maniera ben visibile nelle vicinanze del forno della sauna.

Indicazioni di cura e manutenzione

Per godere a lungo della cabina, essa deve essere pulita ad intervalli regolari.

Il clima dolce e benefico della sauna viene raggiunto tramite diffusione naturale e la capacità del legno di massiccio di immagazzinare il calore.

Per tale motivo le superfici di legno non devono essere trattate in alcun modo.

In caso di lunghi periodi di inutilizzo riscaldare la cabina almeno per una mezz'ora al mese. In tale maniera si evita che essa assorba umidità.

Una leggera trasudazione di resina sulla superficie del legno è inevitabile. I residui di resina secchi possono essere rimossi con carta abrasiva di grana fine.

Installazione elettrica

L'installazione elettrica deve essere eseguita esclusivamente da personale elettrico qualificato e autorizzato in pieno rispetto delle direttive VDE e EVU.

Per indicazioni sul montaggio del forno per sauna e della centralina consultare le istruzioni di montaggio fornite.

Indicazioni speciali

Innestate insieme le tavole da parete – con la linguetta rivolta verso l'alto. Se necessario battete leggermente con un martello di gomma inserendo fra tavola e martello il legno di montaggio, che evita un eventuale

danneggiamento della linguetta. I legni di montaggio sono inclusi nel pacco della parete anteriore della casetta.
 Per controllare la perpendicolarità misurate le diagonali e correggetele sino a che i due valori corrispondono.
 Per evitare un abbassamento della porta di vetro stringete bene la vite a brugola delle cerniere.
 Per evitare danni agli elementi in legno si raccomanda di perforare tutti i punti di avvitaggio a vite! Il presente simbolo richiama la vostra attenzione su tale particolare nel corso delle istruzioni:

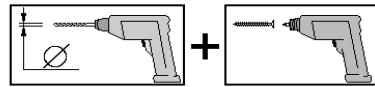

Condizioni di garanzia

La vostra cabina è stata sottoposta in stabilimento ad una accurata verifica e ad controllo finale.
 Durante il periodo di garanzia i componenti difettosi vengono sostituiti gratuitamente. La garanzia non comprende i costi causati dalla sostituzione di componenti difettosi.

La garanzia può essere applicata solamente se accompagnata dalla lista di imballaggio e dallo scontrino di acquisto originali.

La garanzia non copre difetti causati da:

- strato di fondo applicato in maniera non appropriata
- montaggio eseguito in maniera differente da quanto specificato nelle nostre istruzioni di montaggio
- sforzamenti sui componenti
- modifiche alla cabina eseguite di propria iniziativa
- manutenzione errata del legno (vedere le indicazioni per la cura e la manutenzione)

La garanzia non copre ulteriori rivendicazioni e danni derivati.

componenti elettrici devono essere collegati esclusivamente da elettricisti autorizzati.

Il periodo di garanzia per componenti elettrici è di 1 anno. In caso di applicazione della garanzia si prega di inoltrare la fattura dell'elettricista che ha collegato i componenti.

Prima di iniziare con il montaggio tenere a portata di mano i seguenti utensili.

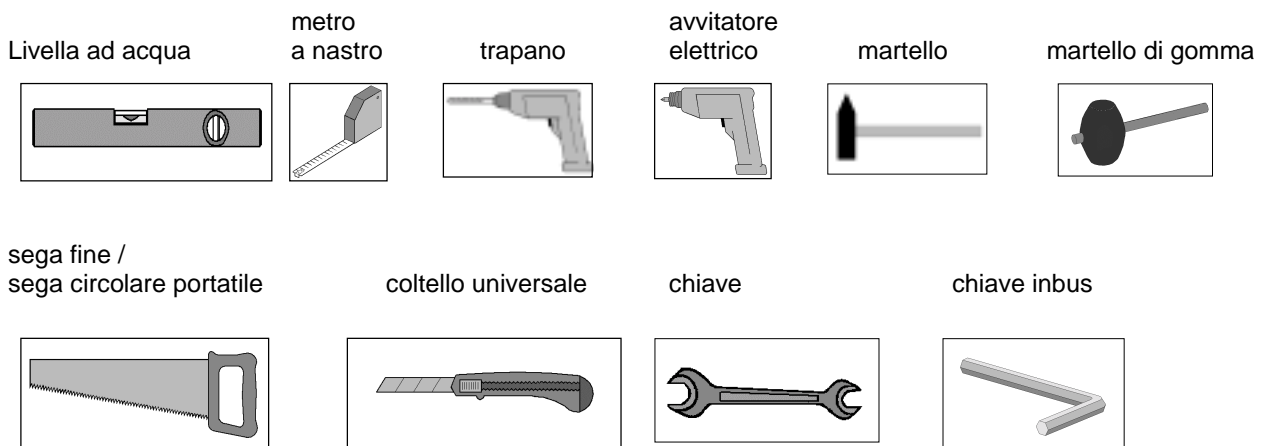





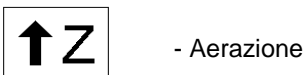



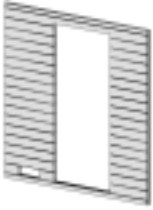

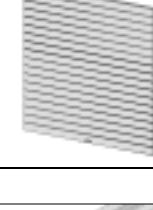

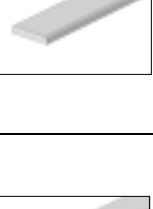
Abbreviazioni / Simboli

cm - Centrimetri
 mm - Millimetri
 ca. - circa / ca.



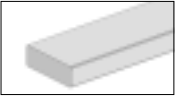

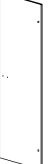

D Stückliste			
GB	Parts list	E	Lista de piezas
F	liste des pièces	P	Lista de peças
I	lista pezzi		



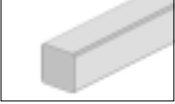
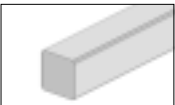

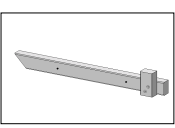
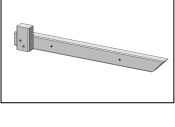
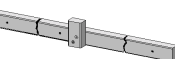
Pos	Bild	Land	Benennung	Abmessung [mm]	Anzahl [Stück]		
					534.2015.18	534.2018.18	534.2020.18
①		D	Frontwand	1806 x 2030	1	1	1
		GB	Front wall				
		F	paroi avant				
		I	parete frontale				
		E	Pared frontal				
		P	Parede frontal				
②		D	Rückwand	1806 x 2030	1	1	1
		GB	Rear wall				
		F	paroi arrière				
		I	parete posteriore				
		E	Pared posterior				
		P	Parede traseira				
③		D	Seitenwand	1306 x 2030 1636 x 2030 1806 x 2030	2 - -	- 2 -	- - 2
		GB	Side wall				
		F	paroi latérale				
		I	parete laterale				
		E	Pared lateral				
		P	Parede lateral				
④		D	Eckpfosten	45 / 45 / 2030	4	4	4
		GB	Corner stud				
		F	poteau d'angle				
		I	montante angolare				
		E	Poste esquinero				
		P	Poste de canto				
⑤		D	Deckleiste	11 / 58 / 2040	8	8	8
		GB	Ceiling batten				
		F	latte de recouvrement				
		I	listello di copertura				
		E	Listo tapajuntas				
		P	Cobrejunta				
⑥		D	Deckleiste	11 / 58 / 1945	1	1	1
		GB	Ceiling batten				
		F	latte de recouvrement				
		I	listello di copertura				
		E	Listo tapajuntas				
		P	Cobrejunta				
⑦		D	U-Profil	31 / 45 / 1825	2	2	2
		GB	U profile				
		F	profilé en U				
		I	profilo a U				
		E	Perfil en U				
		P	Perfil em U				

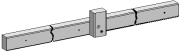

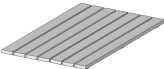
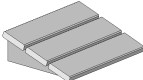
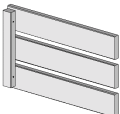
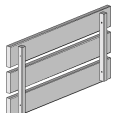
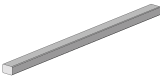
Pos	Bild	Land	Benennung	Abmessung [mm]	Anzahl [Stück]		
					534.2015.18	534.2018.18	534.2020.18
8		D	Falzleiste, senkrecht	15 / 45 / 1825	2	2	2
		GB	Rebate batten, vertical				
		F	latte de feuillure, verticale				
		I	listello aggraffato, perpendicolare				
		E	Listón plegador, vertical				
		P	Friso de encaixe, vertical				
9		D	Falzleiste, quer	15 / 45 / 648	1	1	1
		GB	Rebate batten, crosswise				
		F	latte de feuillure, transversale				
		I	listello aggraffato, obliquo				
		E	Listón plegador, transversal				
		P	Friso de encaixe, transversal				
10		D	Deckleiste	11 / 58 / 1825	4	4	4
		GB	Ceiling batten				
		F	latte de recouvrement				
		I	listello di copertura				
		E	Listo tapajuntas				
		P	Cobrejunta				
11		D	Deckleiste	11 / 58 / 740	2	2	2
		GB	Ceiling batten				
		F	latte de recouvrement				
		I	listello di copertura				
		E	Listo tapajuntas				
		P	Cobrejunta				
12		D	Türrahmen	618 x 1825	1	1	1
		GB	Door frame				
		F	cadre de porte				
		I	telaio della porta				
		E	Marco de puerta				
		P	Caixilho da porta				
13	-				-	-	-
14		D	Saunatur, Ganzglas – 6 mm	550 x 1775	1	1	1
		GB	Sauna door, all glass				
		F	porte de sauna en verre				
		I	porta per sauna, in cristallo				
		E	Puerta de sauna, cristal enterizo				

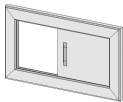
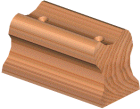



Technische Änderungen vorbehalten!



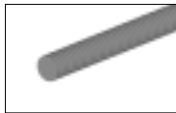
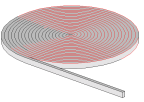
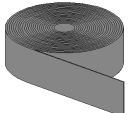

Pos	Bild	Land	Benennung	Abmessung [mm]	Anzahl [Stück]		
					534.2015.18	534.2018.18	534.2020.18
		P	Porta da sauna, integralmente em vidro				
15		D	Trageleiste Decke	30 / 30 / 1790	2	2	2
		GB	Supporting batten, ceiling				
		F	latte porteuse plafond				
		I	listello portante da soffitto				
		E	Listón soporte cubierta				
		P	Régua de suporte do tecto				
16		D	Trageleiste Decke	30 / 30 / 1225 30 / 30 / 1560 30 / 30 / 1728	2 - -	- 2 -	- - 2
		GB	Supporting batten, ceiling				
		F	latte porteuse plafond				
		I	listello portante da soffitto				
		E	Listón soporte cubierta				
		P	Régua de suporte do tecto				
17		D	Deckleiste	11 / 58 / 1225 11 / 58 / 1560 11 / 58 / 1728	1 - -	- 1 -	- - 1
		GB	Ceiling batten				
		F	latte de recouvrement				
		I	listello di copertura				
		E	Listo tapajuntas				
		P	Cobrejunta				
18		D	Deckenelement	893 x 1285 893 x 1615 893 x 1785	2 - -	- 2 -	- - 2
		GB	Ceiling element				
		F	élément de plafond				
		I	elemento soffitta				
		E	Panel de cubierta				
		P	Elemento de cobertura				
19		D	Halterung für Liege, links	550	1	1	1
		GB	Holder for bench, left				
		F	fixation pour couchette, gauche				
		I	supporto per sdraio, sinistra				
		E	Soporte para				
		P	Suporte para divã, esquerda				
20		D	Halterung für Liege, rechts	550	1	1	1
		GB	Holder for bench, right				
		F	fixation pour couchette, droite				
		I	supporto per sdraio, destro				
		E	Soporte para litera, derecha				
		P	Suporte para divã, direita				
21		D	Halterung für Liege, links	925 1090	1 -	- 1	- 1
		GB	Holder for bench, left				
		F	fixation pour couchette, gauche				
		I	supporto per sdraio, sinistra				

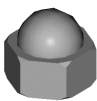
Pos	Bild	Land	Benennung	Abmessung [mm]	Anzahl [Stück]		
					534.2015.18	534.2018.18	534.2020.18
		E	Soporte para				
		P	Suporte para divã, esquerda				
22		D	Halterung für Liege, rechts				
		GB	Holder for bench, right				
		F	fixation pour couchette, droite	925	1	-	-
		I	supporto per sdraio, destro	1090	-	1	1
		E	Soporte para litera, derecha				
		P	Suporte para divã, direita				
23		D	Saunaliege				
		GB	Sauna bench				
		F	couchette de sauna	550 x 1785	2	2	2
		I	sdraio per sauna				
		E	Litera de sauna				
		P	Divã para sauna				
24		D	Bodenrost				
		GB	Sewer grating				
		F	grille de sol	614 x 1000	1	1	1
		I	griglia del pavimento				
		E	Rejilla de piso				
25		D	Kopfstütze				
		GB	Sewer grating				
		F	grille de sol	325 / 240	2	2	2
		I	griglia del pavimento				
		E	Rejilla de piso				
		P	Grelha do piso				
26		D	Ofenschutz, Seitenteil				
		GB	Furnace protection, side section				
		F	protection de poêle, partie latérale	460 x 280	2	2	2
		I	protezione stufa, elemento laterale				
		E	Protección estufa, parte lateral				
27		D	Ofenschutz, Frontenteil				
		GB	Furnace protection, front section				
		F	protection de poêle, partie avant	568 x 280	1	1	1
		I	protezione stufa, elemento anteriore				
		E	Protección estufa, parte frontal				
		P	Proteção do forno, parte frontal				
28		D	Ofenschutz, Pfosten				
		GB	Furnace protection, stud				
		F	protection de poêle, poteau	25 / 35 / 635	2	2	2
		I	protezione stufa, montante				

Pos	Bild	Land	Benennung	Abmessung [mm]	Anzahl [Stück]			
					534.2015.18	534.2018.18	534.2020.18	
		E	Protección estufa, poste					
		P	Protecção do forno, poste					
39		D	Abluftschieber	410 / 235	1	1	1	
		GB	Outgoing air slide valve					
		F	clapet d'air sortant					
		I	saracinesca di scarico					
		E	Corredera aire de salida					
		P	Corrediça de evacuaçãõ do ar					
30	-							
31		D	Saunatürgriff, innen	40 / 90 / 45	1	1	1	
		GB	Sauna door handle, interior					
		F	poignée de porte de sauna intérieure					
		I	maniglia per porta da sauna, interna					
		E	Manija puerta sauna, interior					
P	Manípulo da porta da sauna, interior							
32		D	Saunatürgriff, außen	40 / 160 / 45-	1	1	1	
		GB	Sauna door handle, exterior					
		F	poignée de porte de sauna extérieure					
		I	maniglia per porta da sauna, esterna					
		E	Manija puerta sauna, exterior					
P	Manípulo da porta da sauna, exterior							
33		D	Magnetverschlus		1	1	1	
34		D	Haftscheibe	-	1	1	1	
35		D	Montageholz	45/60/300	4	4	4	
		GB	Assembly timber					
		F	pièce de montage					
		I	legno di montaggio					

Pos	Bild	Land	Benennung	Abmessung [mm]	Anzahl [Stück]		
					534.2015.18	534.2018.18	534.2020.18
		E	Madero de montaje				
		P	Madeira para montagem				
36	-						
37		D	Beschlagsatz für Ganzglastür	-	2	2	2
		GB	Screw-down band for glass door				
		F	paumelle à visser pour porte en verre				
		I	cerniera di avvitamento per porta in cristallo				
		E	Cinta para atornillar puerta vidrio				
		P	Rebordo aparafusável para porta de vidro				
38		D	Gummiband	45x120	2	2	2
		GB	Rubber band				
		F	ruban caoutchouc				
		I	nastro di gomma, elastico				
		E	Cinta de goma				
		P	Fita de borracha				
39		D	Gewindestange	M8 x 2050	1	3	3
		GB	Threaded rod				
		F	tige filetée				
		I	asta filettata				
		E	Varilla roscada				
		P	Varão roscado				
40		D	Dichtband Sauna-Decke	10 m	1	1	1
		GB	Sealing tape, sauna ceiling				
		F	bande d'étanchéité plafond du sauna				
		I	nastro sigillante per soffitto sauna				
		E	Cinta adhesiva techo sauna				
		P	Fita isoladora do tecto da sauna				
41		D	Gummiband	10 m	1	1	1
		GB	Rubber band				
		F	ruban caoutchouc				
		I	nastro di gomma, elastico				
		E	Cinta de goma				
		P	Fita de borracha				
42							

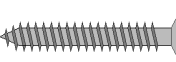
Pos	Bild	Land	Benennung	Abmessung [mm]	Anzahl [Stück]		
					534.2015.18	534.2018.18	534.2020.18
43	-						
44	-						
45	-						
46		D	Einschlagmutter	M8	1	3	3
		GB	Drive-in nut				
		F	écrou à enfoncer				
		I	dado a battuta				
		E	Tuerca de fijación				
		P	Porca de cravar				
47		D	Unterlegscheibscheibe	8,4	1	3	3
		GB	Plain washer				
		F	rondelle				
		I	rondella				
		E	Arandela				
		P	Anilha plana				
48		D	Hutmutter	M8	1	3	3
		GB	Cap nut				
		F	écrou borgne				
		I	dado a cappello				
		E	Tuerca de caperuza				
		P	Porca de capa				
49		D	Schraube	5,0 x 100	160	160	160
		GB	Screw				
		F	vis				
		I	vite				

Pos	Bild	Land	Benennung	Abmessung [mm]	Anzahl [Stück]		
					534.2015.18	534.2018.18	534.2020.18
		E	Tornillo				
		P	Parafuso				
50		D	Schraube	5,0 x 80	50	50	50
		GB	Screw				
		F	vis				
		I	vite				
		E	Tornillo				
		P	Parafuso				
51		D	Schraube	4,5 x 70	28	28	28
		GB	Screw				
		F	vis				
		I	vite				
		E	Tornillo				
		P	Parafuso				
52		D	Schraube	6,0 x 60	21	21	21
		GB	Screw				
		F	vis				
		I	vite				
		E	Tornillo				
		P	Parafuso				
53	-						
54		D	Schraube	4,0 x 60	22	22	22
		GB	Screw				
		F	vis				
		I	vite				
		E	Tornillo				
		P	Parafuso				
55		D	Schraube	3,5 x 35	40	40	40
		GB	Screw				
		F	vis				
		I	vite				
		E	Tornillo				
		P	Parafuso				
56	-						

Pos	Bild	Land	Benennung	Abmessung [mm]	Anzahl [Stück]		
					534.2015.18	534.2018.18	534.2020.18
57	-						
58	-						
59		D	Drahtstift	16 x 30	90	90	90
		GB	Wire nail				
		F	pointe				
		I	spina in filo metallico				
		E	Punta de París				
		P	Prego de cabeça chata				

Aufbauübersicht

Art.-Nr.: 534.2015.10

GB	Overview
F	vue d'ensemble
I	panoramica
E	Vista general
P	Panorâmica

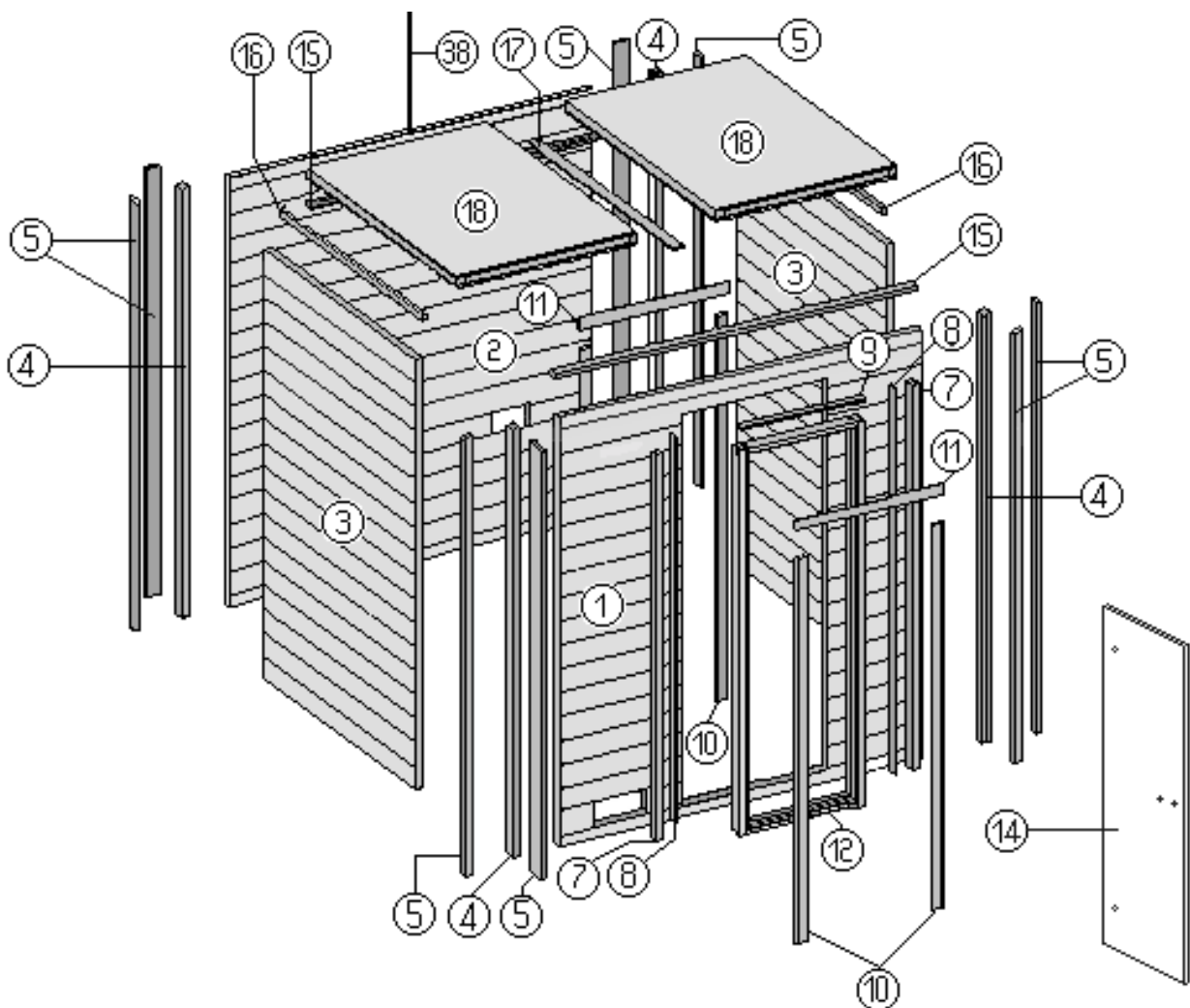
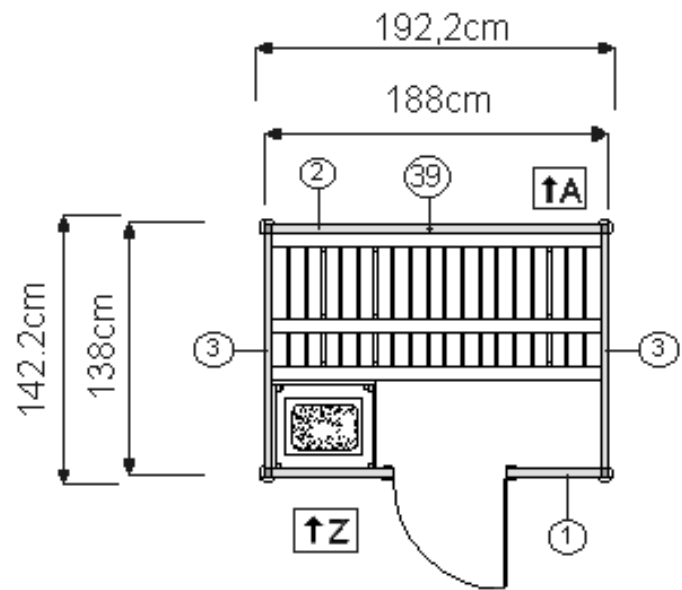

Wandaufbau

Art.-Nr.: 534.2015.10

GB	Wall structure
F	montage de la paroi
I	struttura della parete
E	Montaje de la pared
P	Composição das paredes

D	Frontwand
GB	Front wall
F	paroi avant
I	parete frontale
E	Pared frontal
P	Parede frontal
D	Frontwand

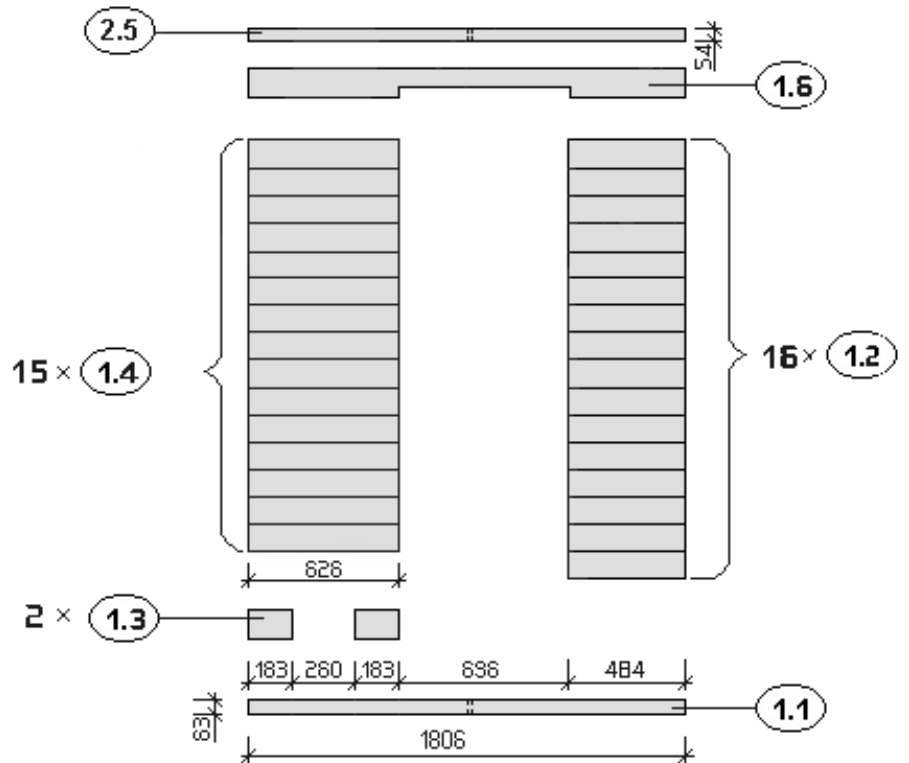

D	Rückwand
GB	Rear wall
F	paroi arrière
I	parete posteriore
E	Pared posterior
P	Parede traseira
D	Rückwand

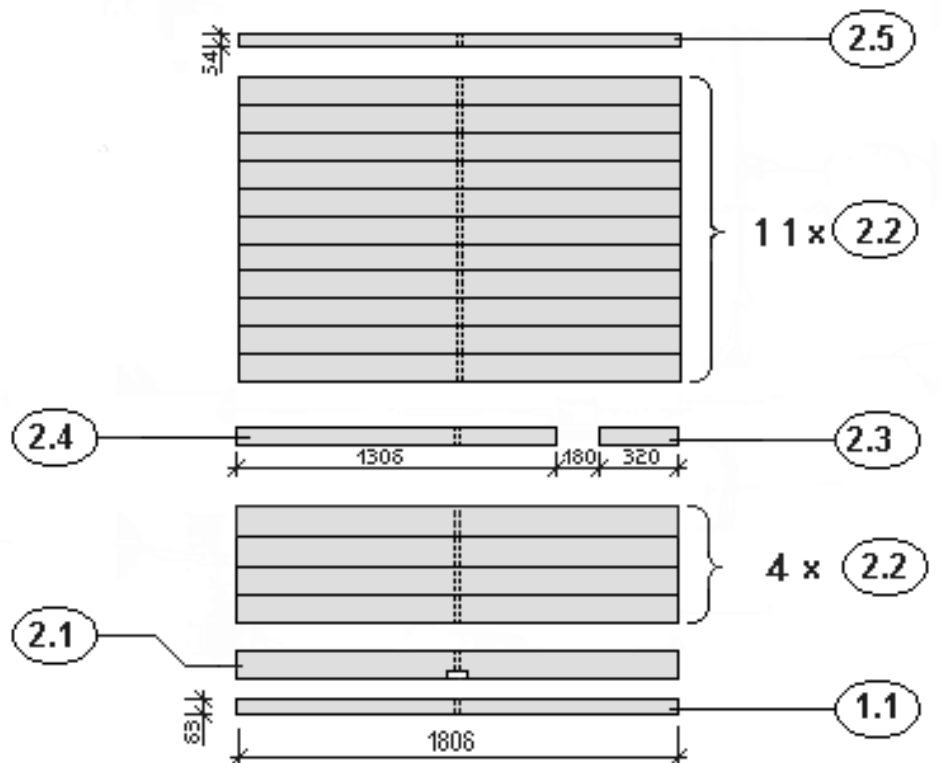

D	Seitenwand
GB	Side wall
F	paroi latérale
I	parete laterale
E	Pared lateral
P	Parede lateral
D	Seitenwand

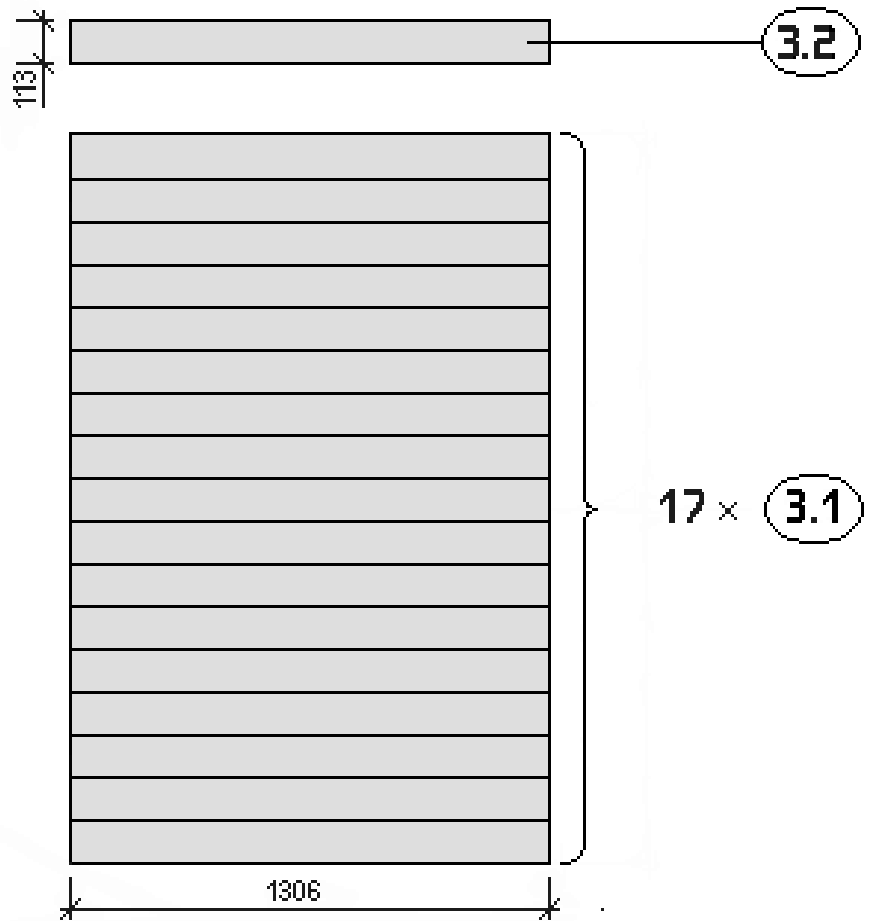

Pos	Abmessung (mm)	Stück	Art.-Nr.	Wandpaket
1.1	45/63/1806	2	G530.01.0001	W 2221
1.2	45/121/484	16	G530.01.0017	W 2221/2222
1.3	45/121/183	2	G530.01.0014	W 2221
1.4	45/121/626	15	G530.01.0031	W 2222
1.5	-	-	-	-
1.6	45/121/1806	1	G530.01.0032	W 2221
1.7	-	-	-	-
2.1	45/121/1806	1	G530.01.0004	W 2221
2.2	45/121/1806	15	G530.01.0003	W 2221/2222
2.3	45/121/320	1	G530.01.0011	W 2221
2.4	45/121/1306	1	G530.01.0012	W 2221
2.5	45/54/1806	2	G530.01.0007	W 2221
3.1	45/121/1306	34	G530.01.0021	W 2205/2206
3.2	45/113/1306	2	G530.01.0023	W 2205

Aufbauübersicht

Art.-Nr.: 534.2018.10

GB	Overview
F	vue d'ensemble
I	panoramica
E	Vista general
P	Panorâmica

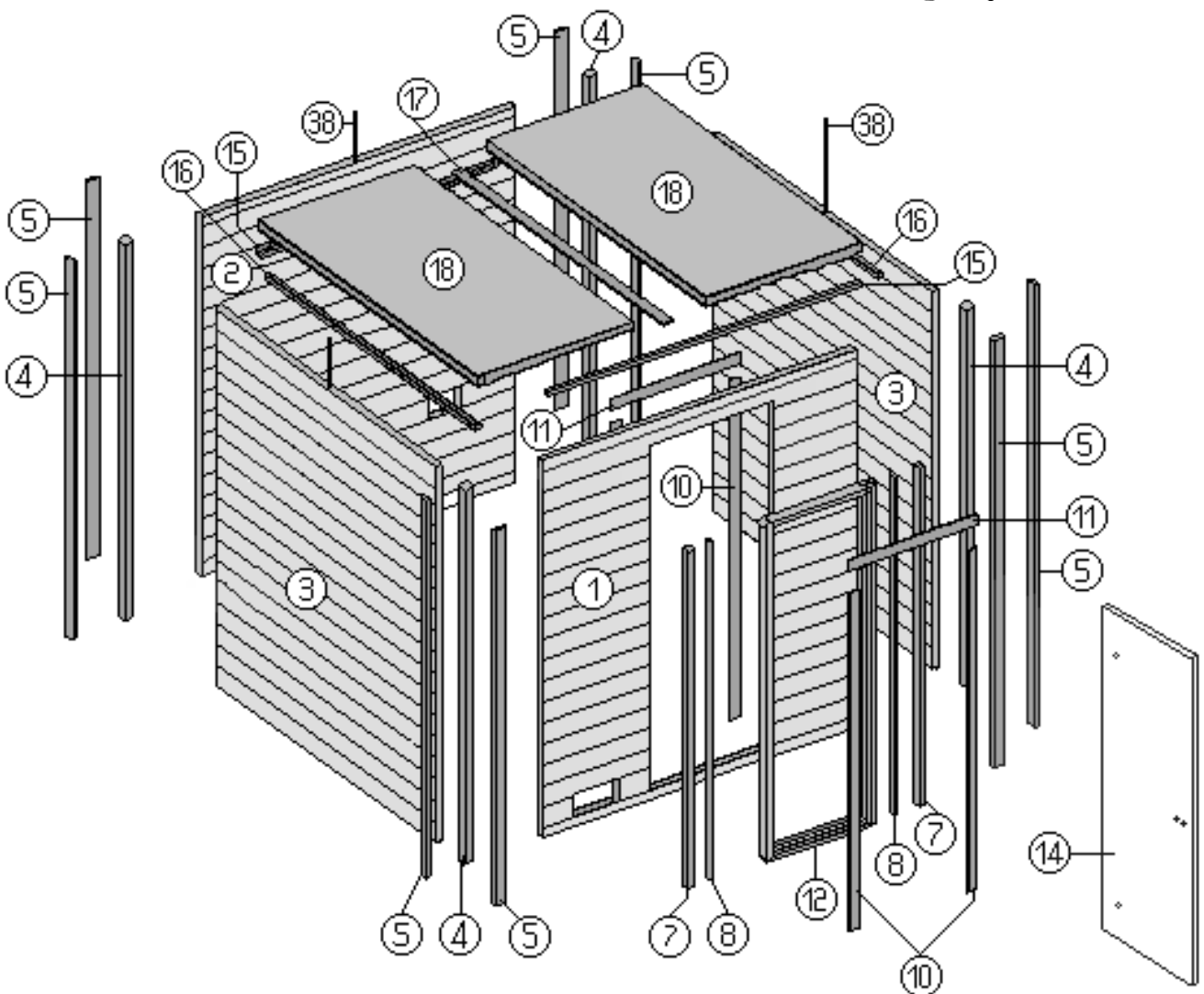
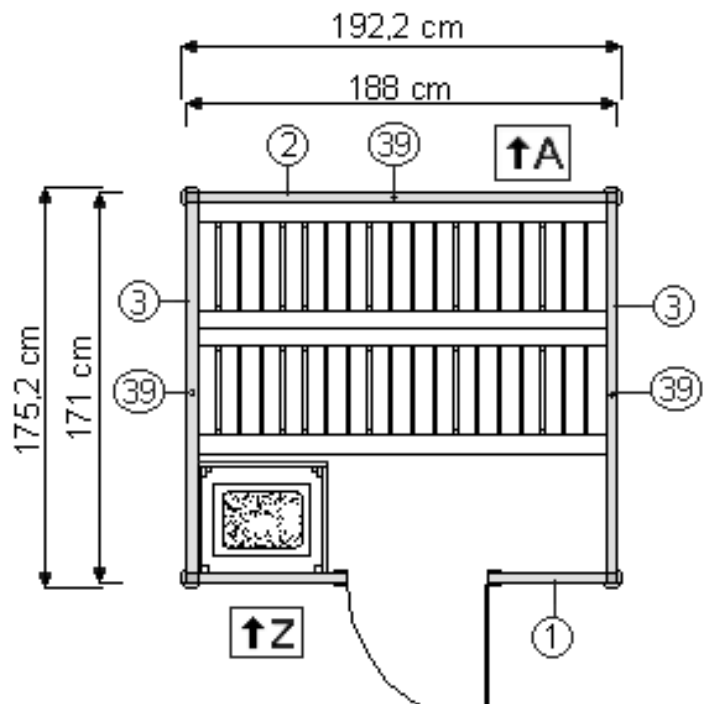

Wandaufbau

Art.-Nr.: 534.2018.10

GB	Wall structure
F	montage de la paroi
I	struttura della parete
E	Montaje de la pared
P	Composição das paredes

D	Frontwand	15 x	1.4
GB	Front wall		
F	paroi avant		
I	parete frontale		
E	Pared frontal		
P	Parede frontal		
D	Frontwand	2 x	1.3

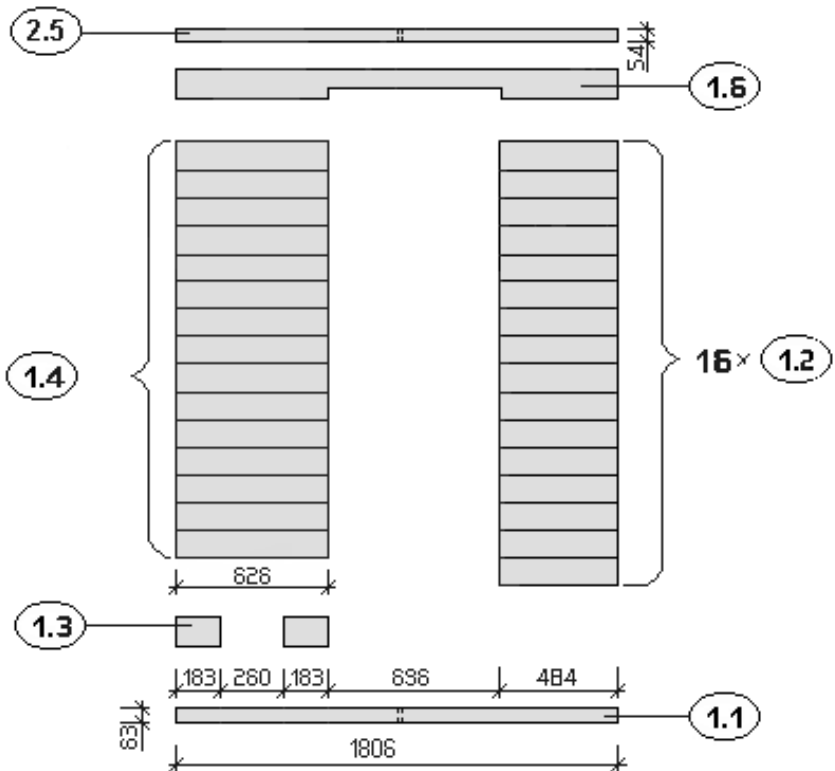

D	Rückwand
GB	Rear wall
F	paroi arrière
I	parete posteriore
E	Pared posterior
P	Parede traseira
D	Rückwand

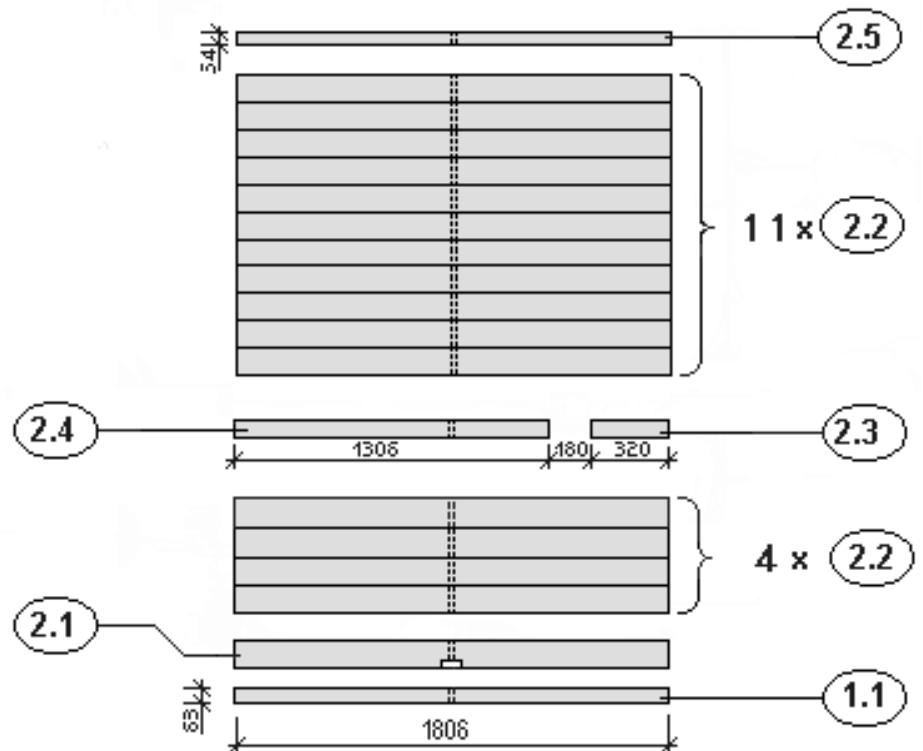

D	Seitenwand
GB	Side wall
F	paroi latérale
I	parete laterale
E	Pared lateral
P	Parede lateral

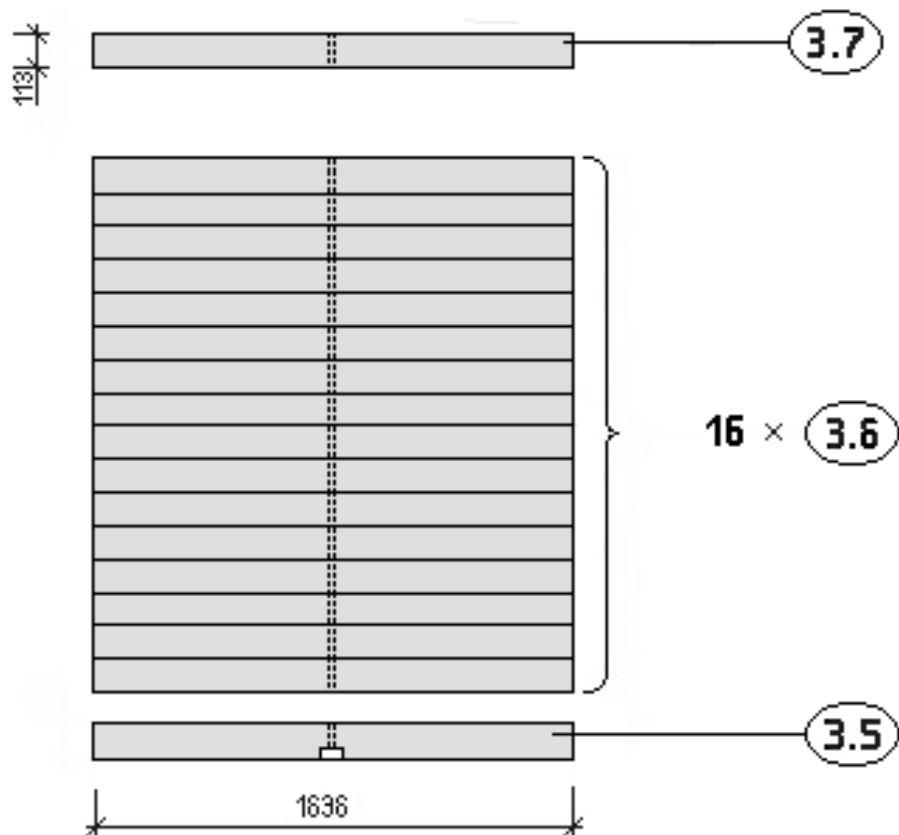

Pos	Abmessung (mm)	Stück	Art.-Nr.	Wandpaket
1.1	45/63/1806	2	G530.01.0001	W 2221
1.2	45/121/484	16	G530.01.0017	W 2221/2222
1.3	45/121/183	2	G530.01.0014	W 2221
1.4	45/121/626	15	G530.01.0031	W 2222
1.5	-	-	-	-
1.6	45/121/1806	1	G530.01.0032	W 2221
1.7	-	-	-	-
2.1	45/121/1806	1	G530.01.0004	W 2221
2.2	45/121/1806	15	G530.01.0003	W 2221/2222
2.3	45/121/320	1	G530.01.0011	W 2221
2.4	45/121/1306	1	G530.01.0012	W 2221
2.5	45/54/1806	2	G530.01.0007	W 2221
3.5	45/121/1636	2	G530.01.0025	W 2207
3.6	45/121/1636	32	G530.01.0024	W 2207/W 2208
3.7	45/113/1636	2	G530.01.0026	W 2207

Aufbauübersicht

Art.-Nr.: 534.2020.10

GB	Overview
F	vue d'ensemble
I	panoramica
E	Vista general
P	Panorâmica

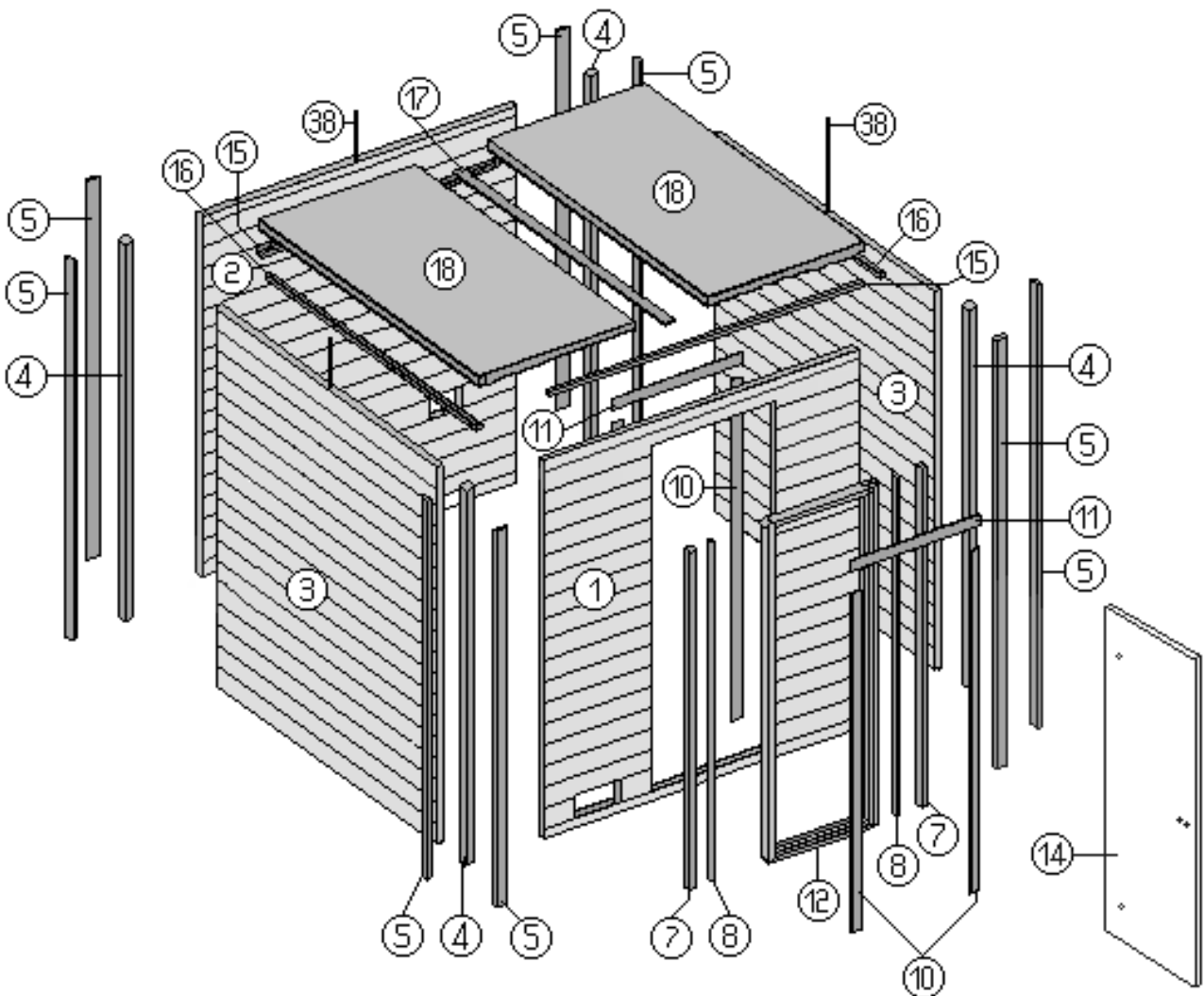
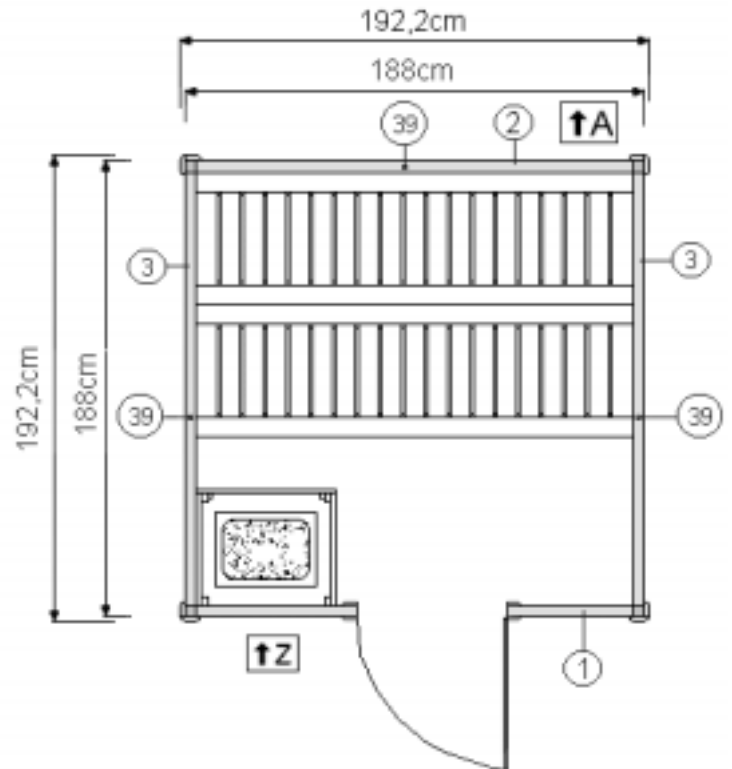

Wandaufbau

Art.-Nr.: 534.2020.10

GB	Wall structure
F	montage de la paroi
I	struttura della parete
E	Montaje de la pared
P	Composição das paredes

D	Frontwand
GB	Front wall
F	paroi avant
I	parete frontale
E	Pared frontal
P	Parede frontal

D	Rückwand
GB	Rear wall
F	paroi arrière
I	parete posteriore
E	Pared posterior
P	Parede traseira

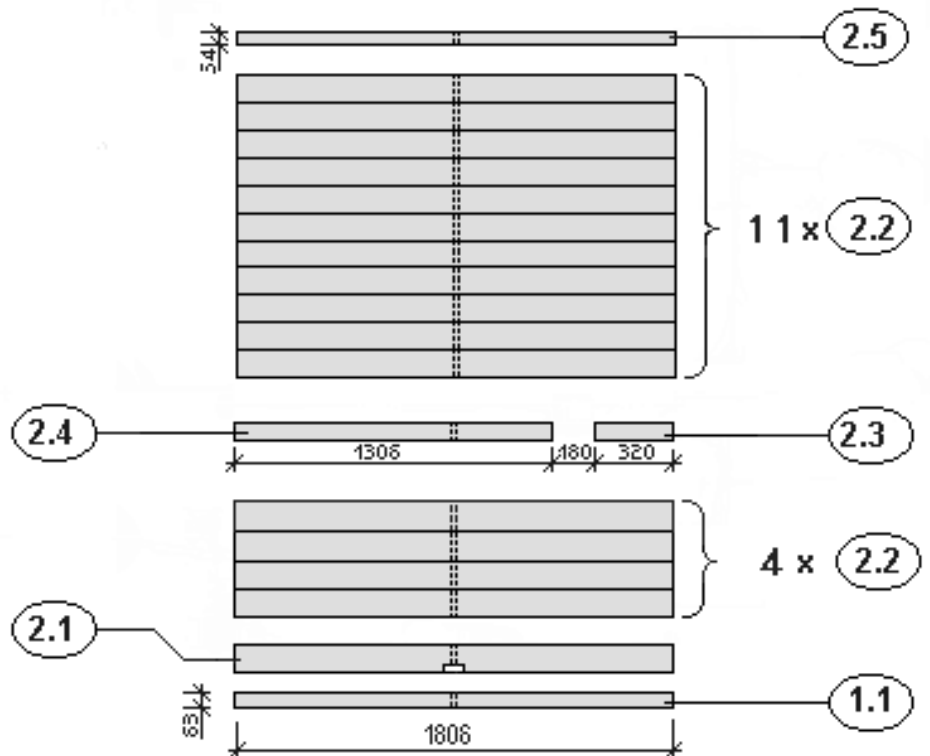
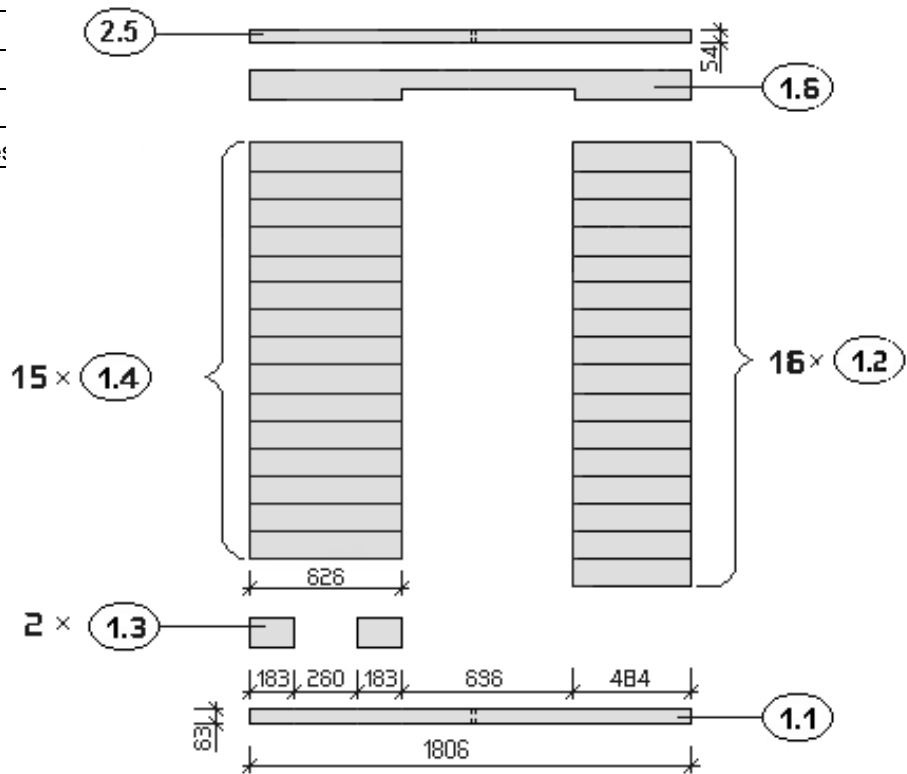

D	Seitenwand
GB	Side wall
F	paroi latérale
I	parete laterale
E	Pared lateral
P	Parede lateral

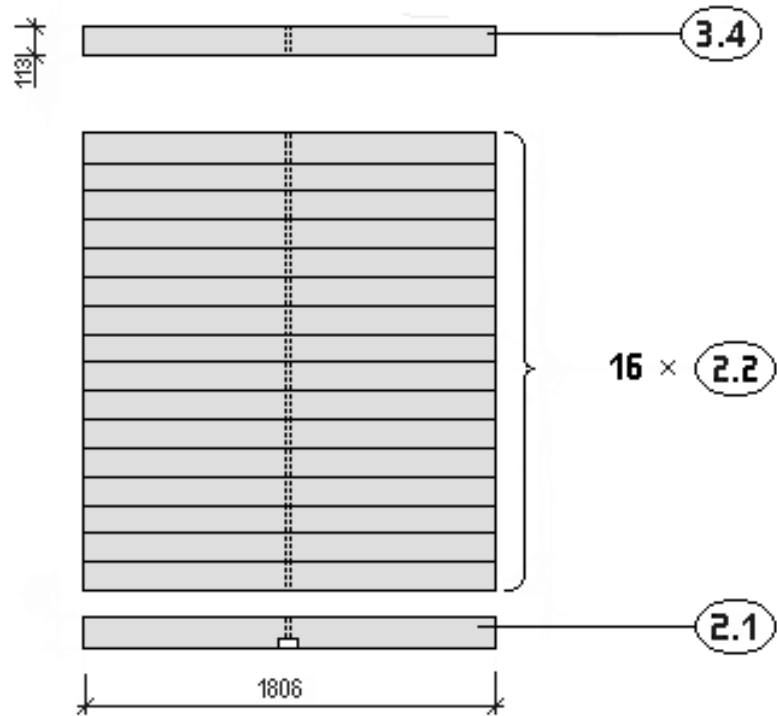

Pos	Abmessung (mm)	Stück	Art.-Nr.	Wandpaket
1.1	45/63/1806	2	G530.01.0001	W 2221
1.2	45/121/484	16	G530.01.0017	W 2221/W2222
1.3	45/121/183	2	G530.01.0014	W 2221
1.4	45/121/626	15	G530.01.0031	W 2222
1.5	-	-	-	-
1.6	45/121/1806	1	G530.01.0032	W 2221
1.7	-	-	-	-
2.1	45/121/1806	3	G530.01.0004	W 2221/W2209
2.2	45/121/1806	47	G530.01.0003	W 2221/W 2222 W 2209/W 2210
2.3	45/121/320	1	G530.01.0011	W 2221
2.4	45/121/1306	1	G530.01.0012	W 2221
2.5	45/54/1806	2	G530.01.0007	W 2221
3.4	45/113/1306	2	G530.01.00227	W 2209

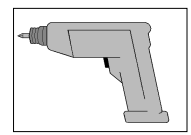
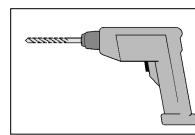
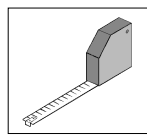
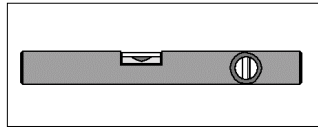

1



Abb.: Art.-Nr. 534.2018.18.00



2

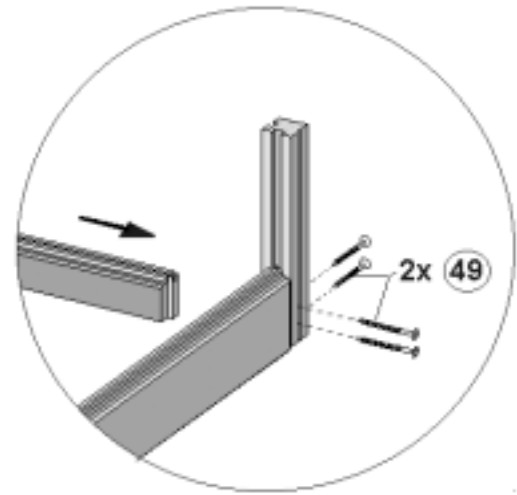
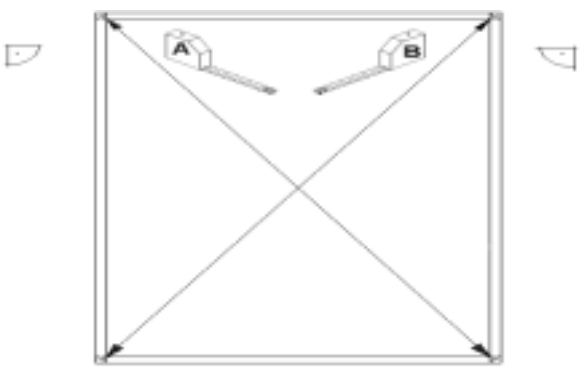
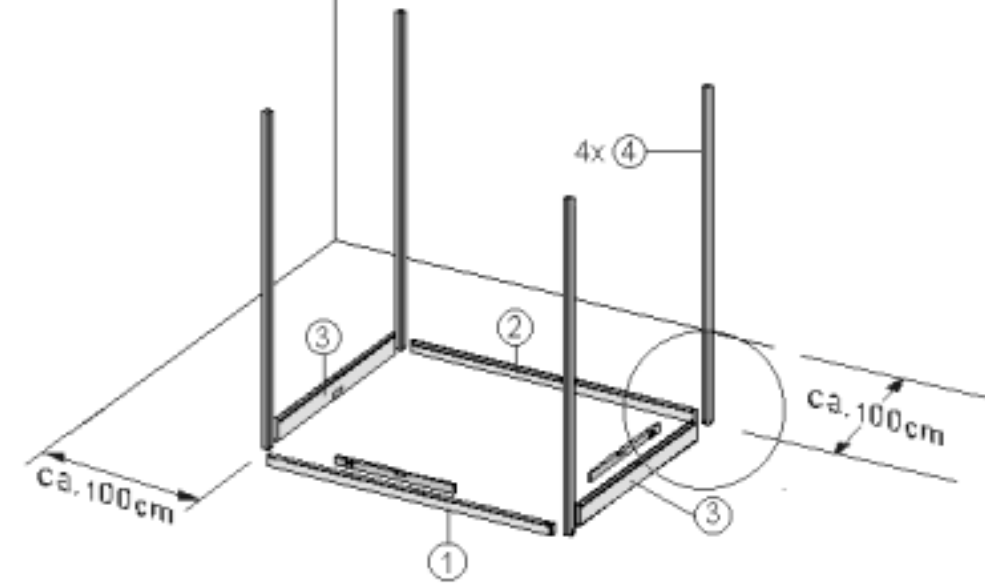
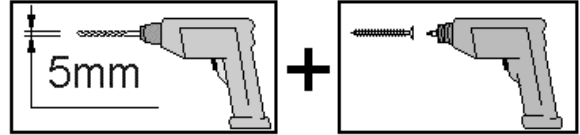
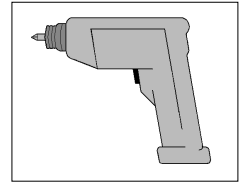
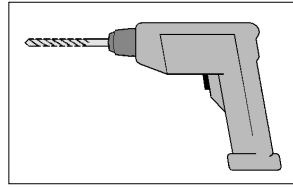
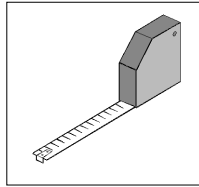

Abb.: Art.-Nr. 534.2018.18.00



3

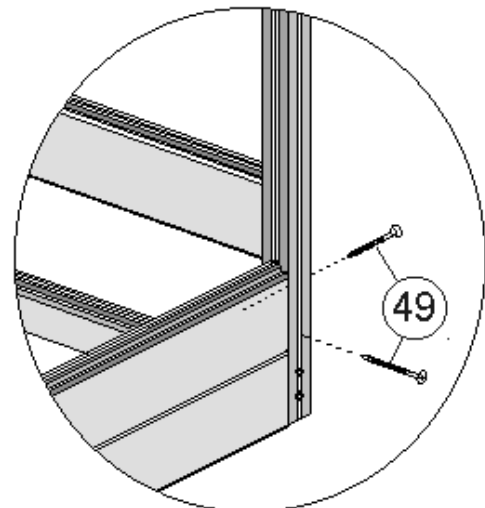
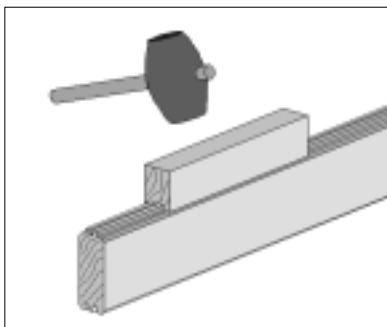
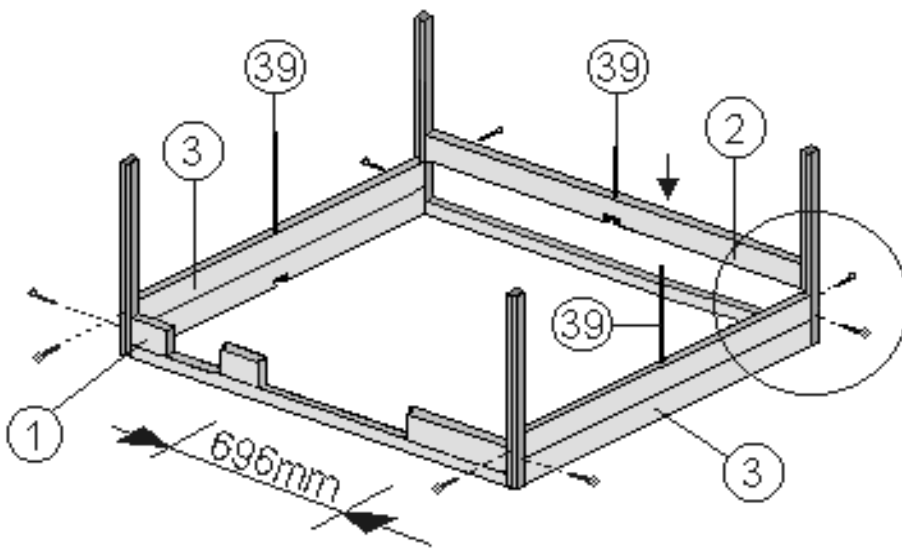
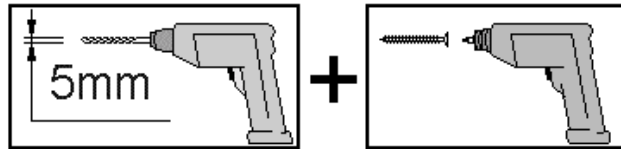
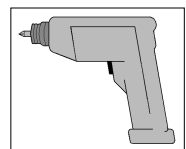
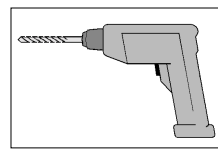
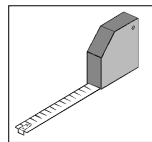
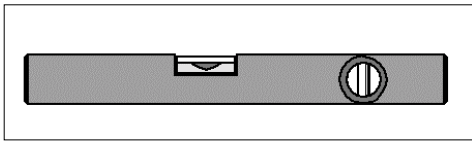

Abb.: Art.-Nr. 534.2018.18.00



4

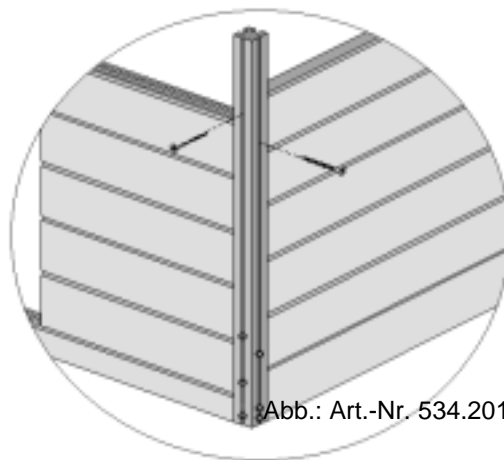
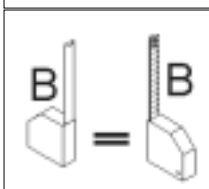
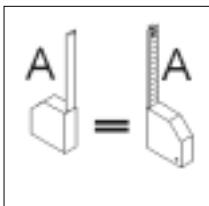
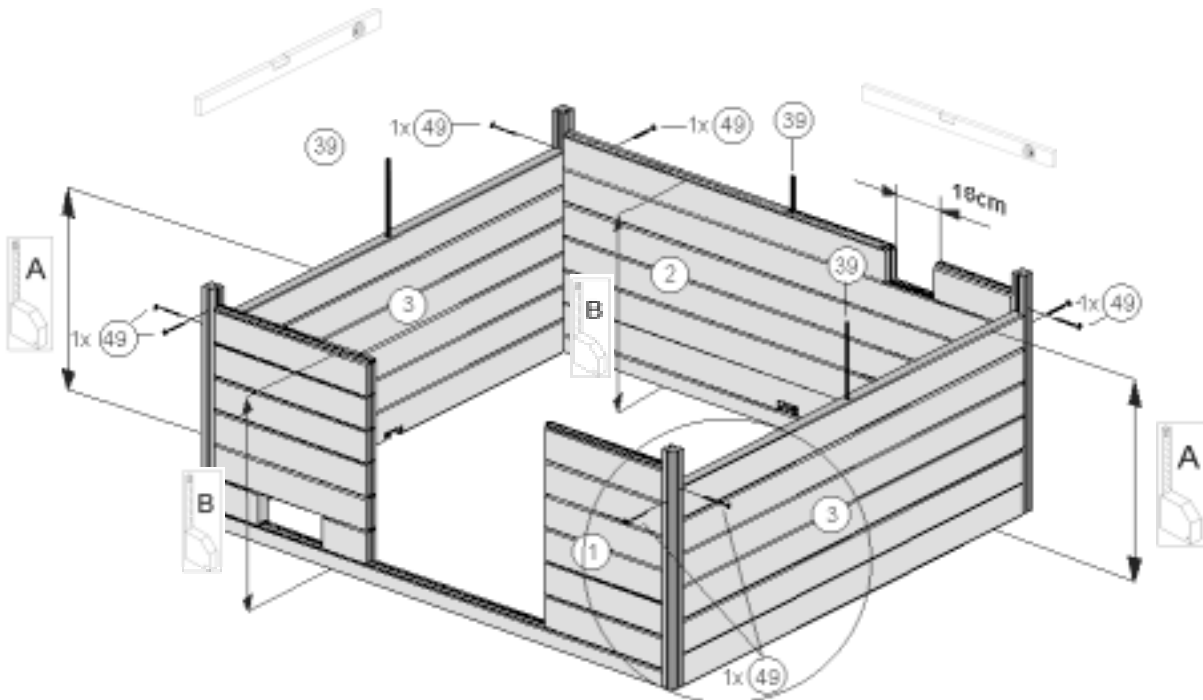
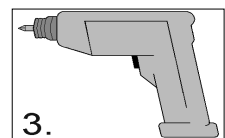
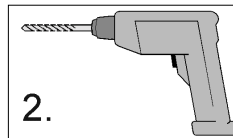
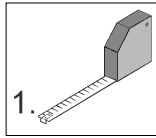
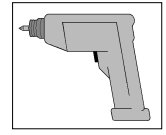
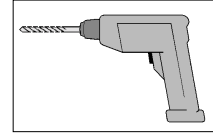
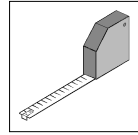
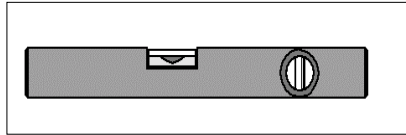

Abb.:Art.-Nr.534.2018.18.00



5

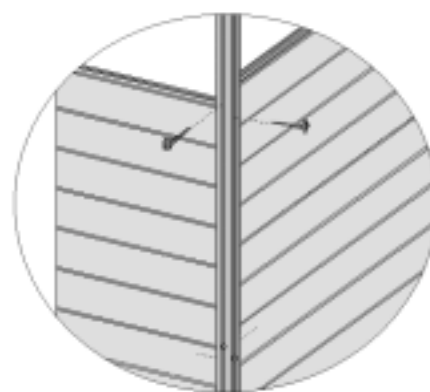
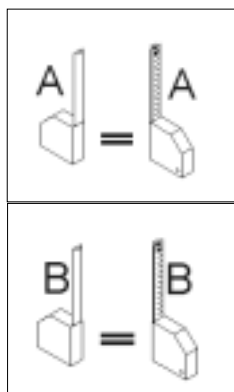
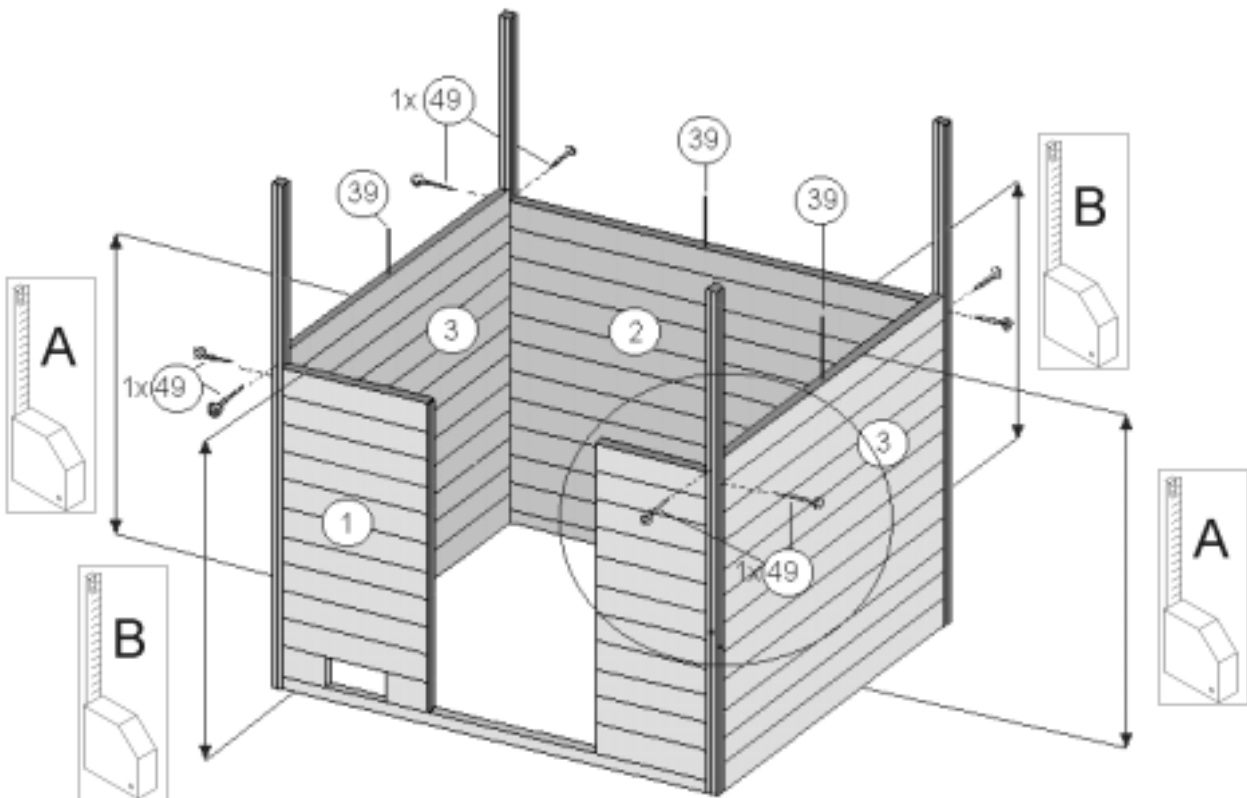
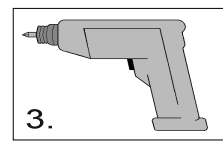
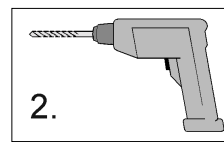
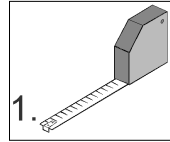
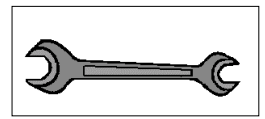
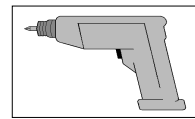
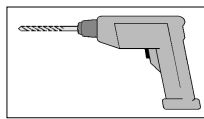
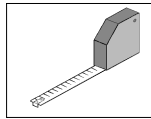
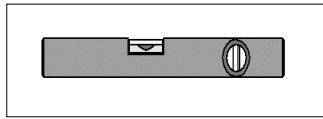

Abb.:Art.-Nr.534.2018.18.00



A

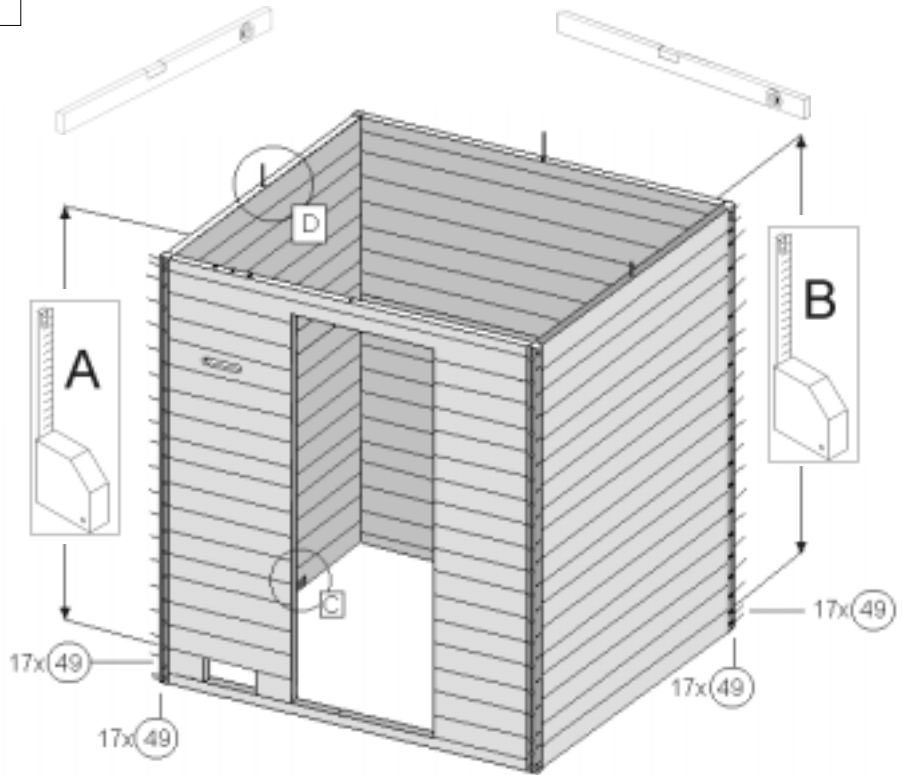
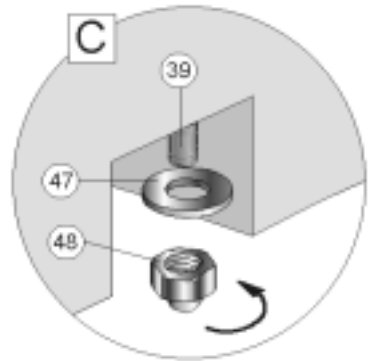
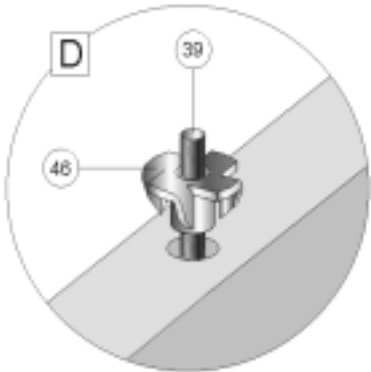
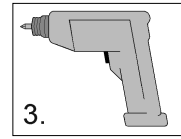
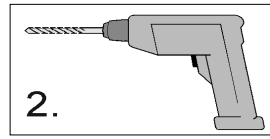
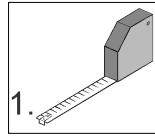
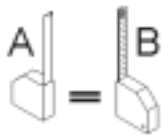
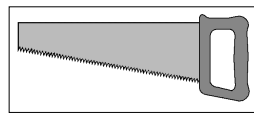
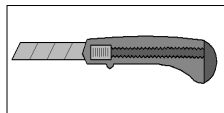
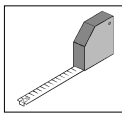
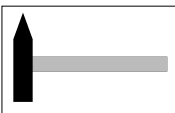
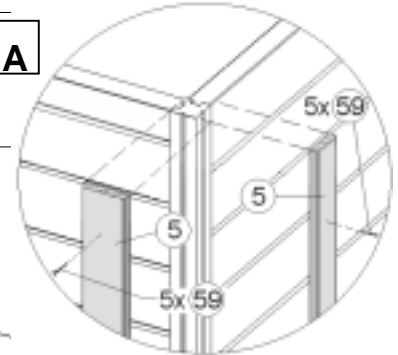

6

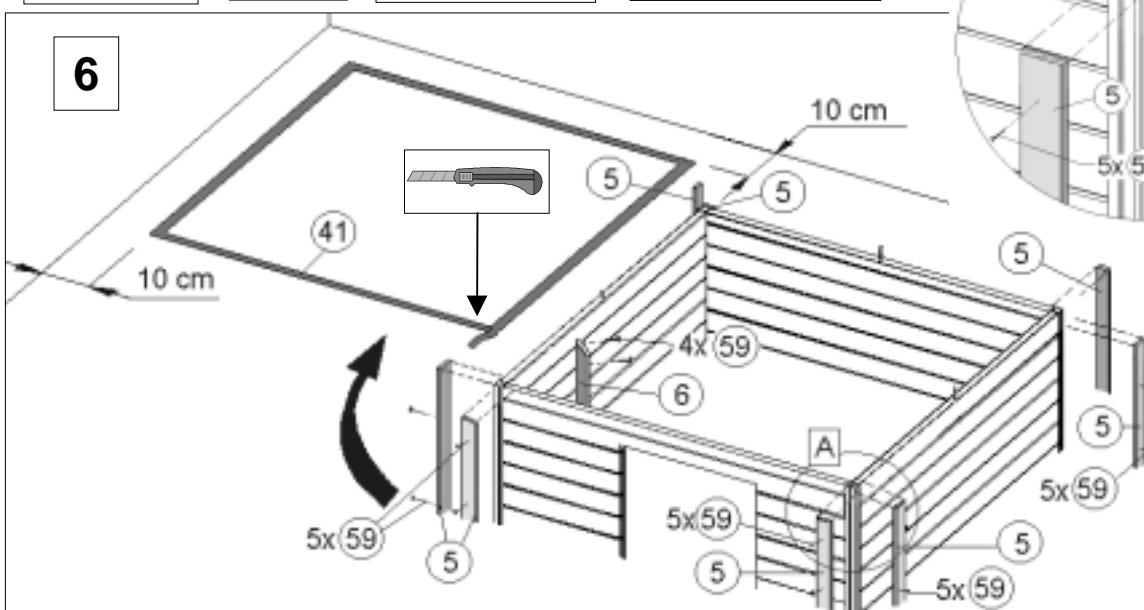

7

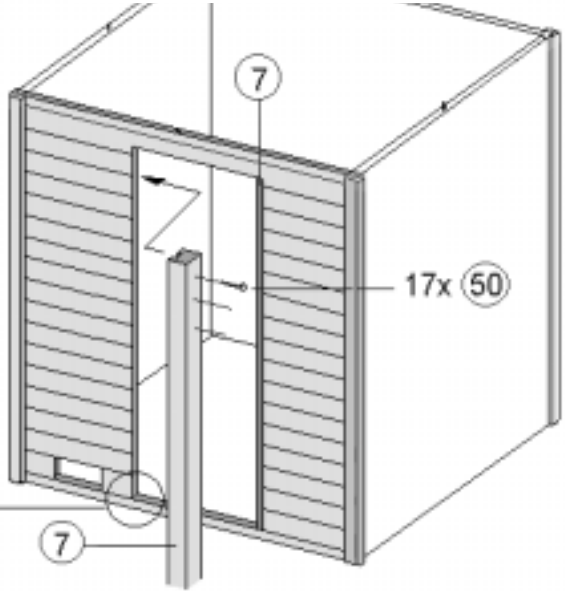
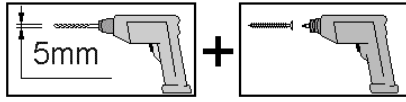
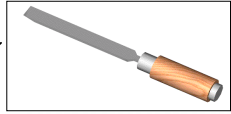
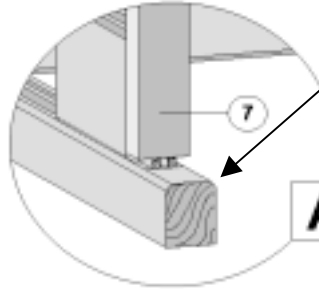
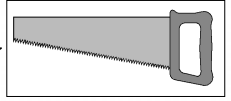
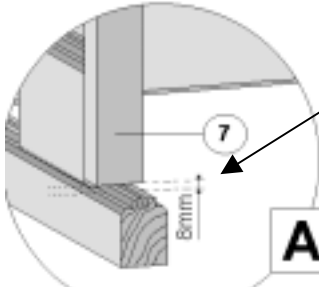
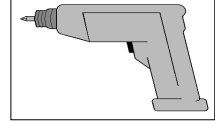
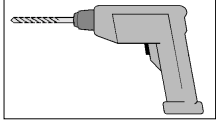
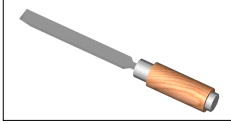
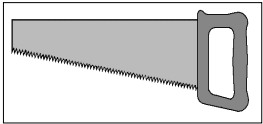

8

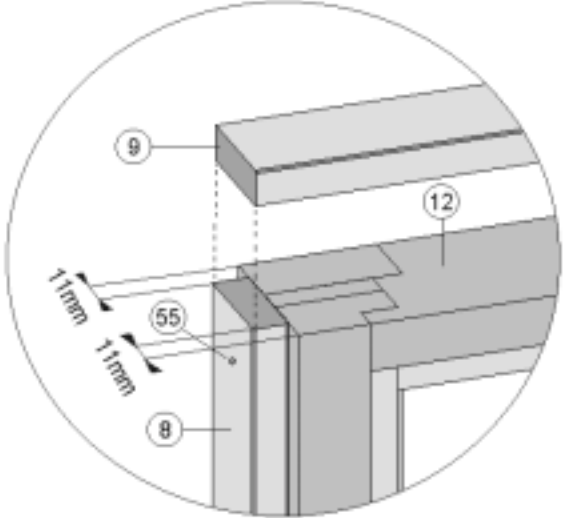
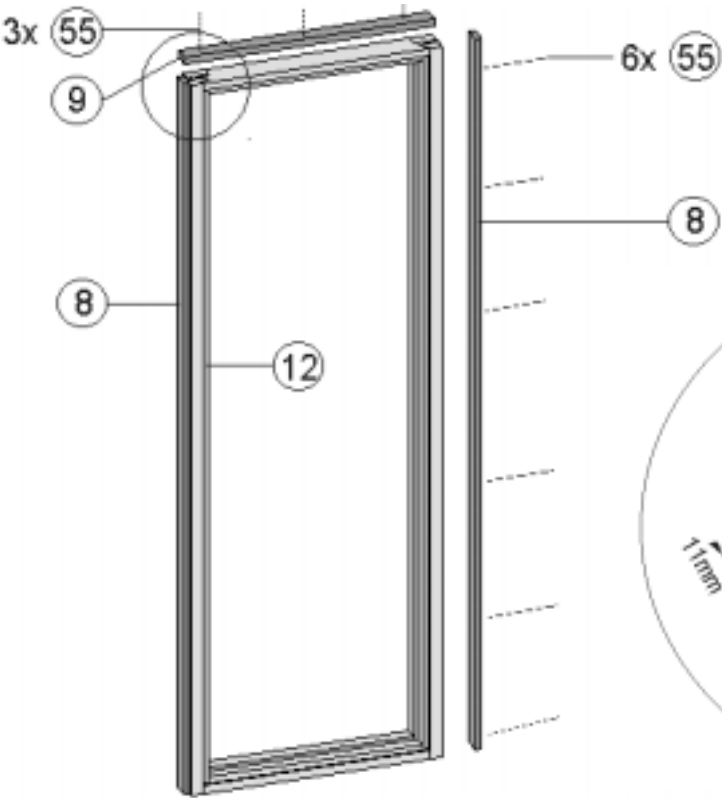
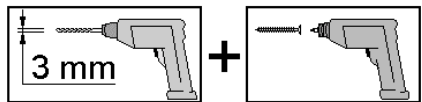

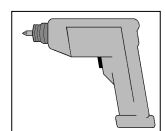
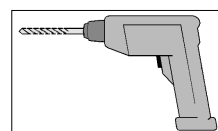
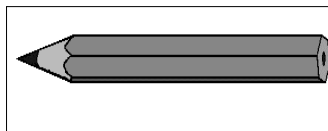
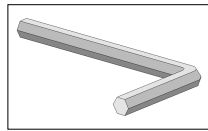
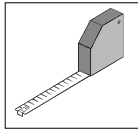

9

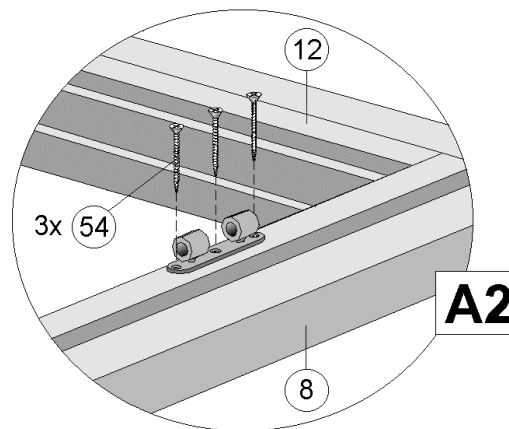
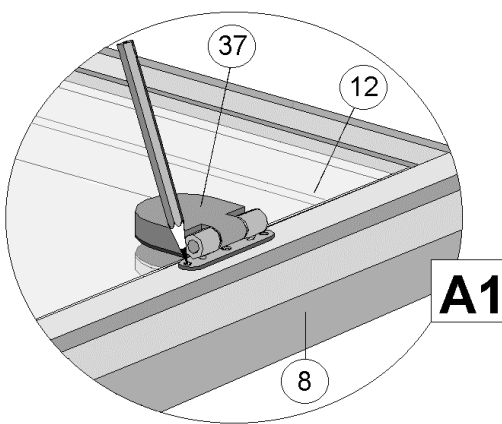
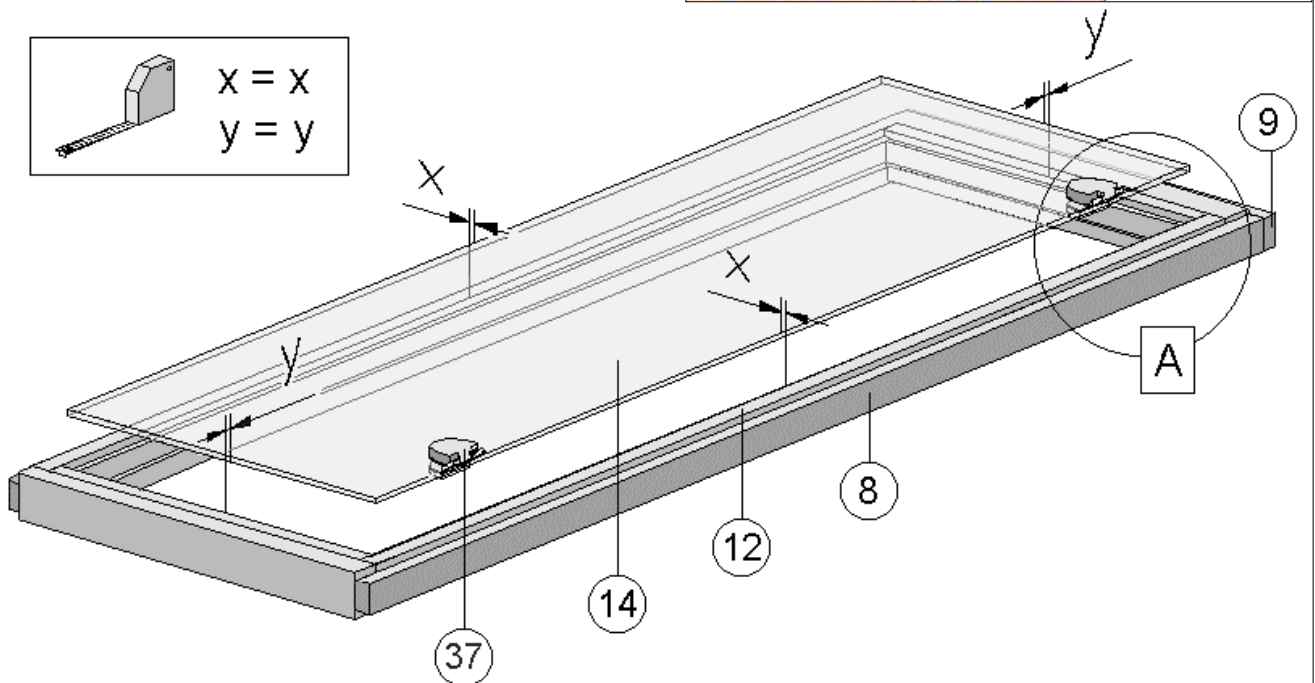
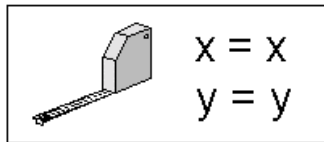
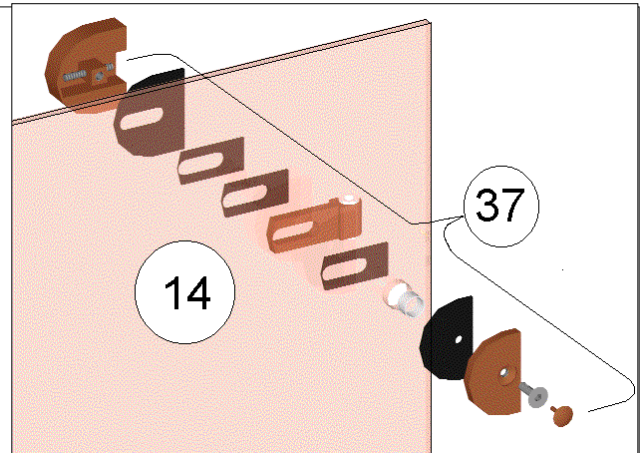

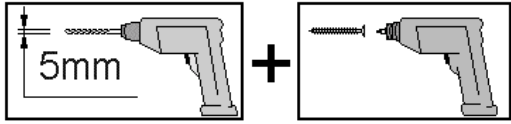
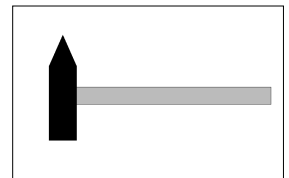
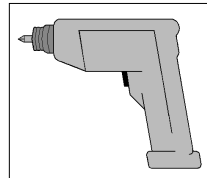
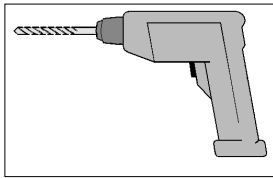
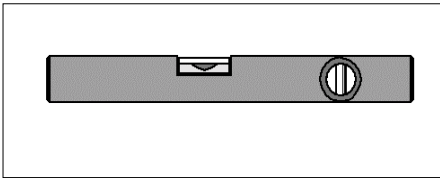

10

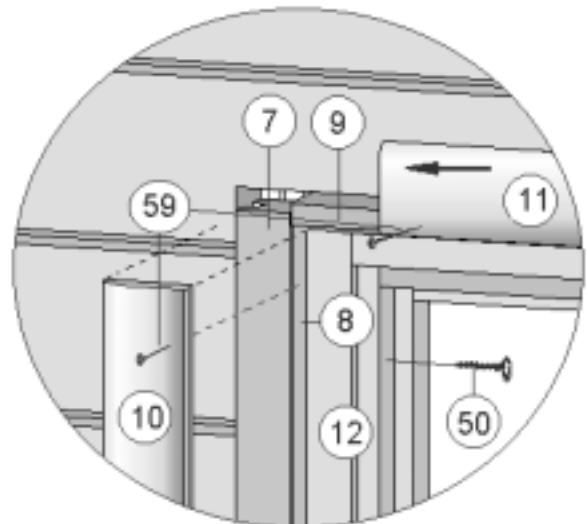
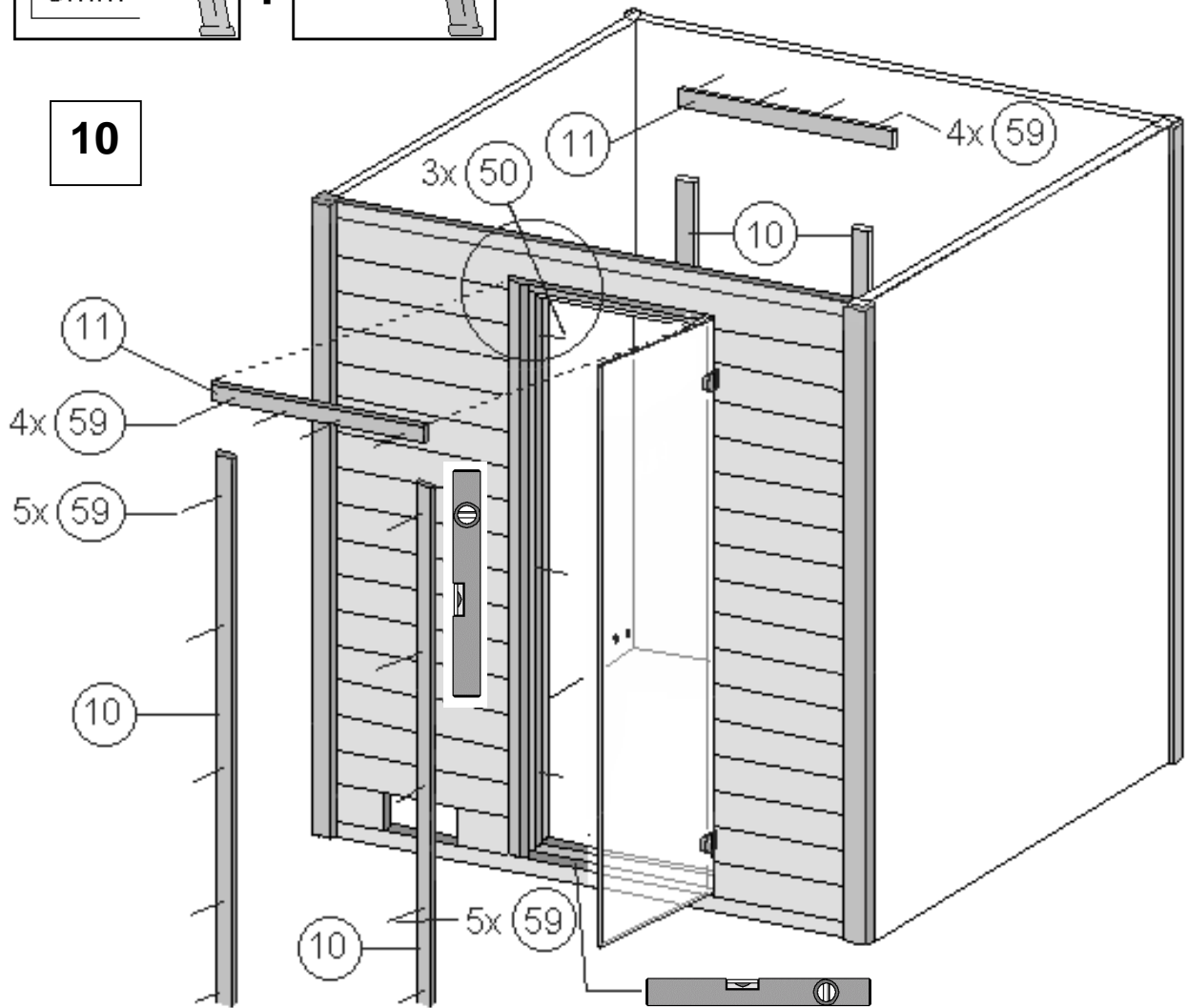

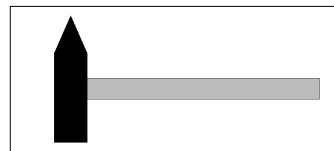
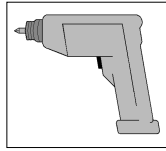
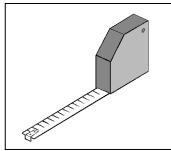

11

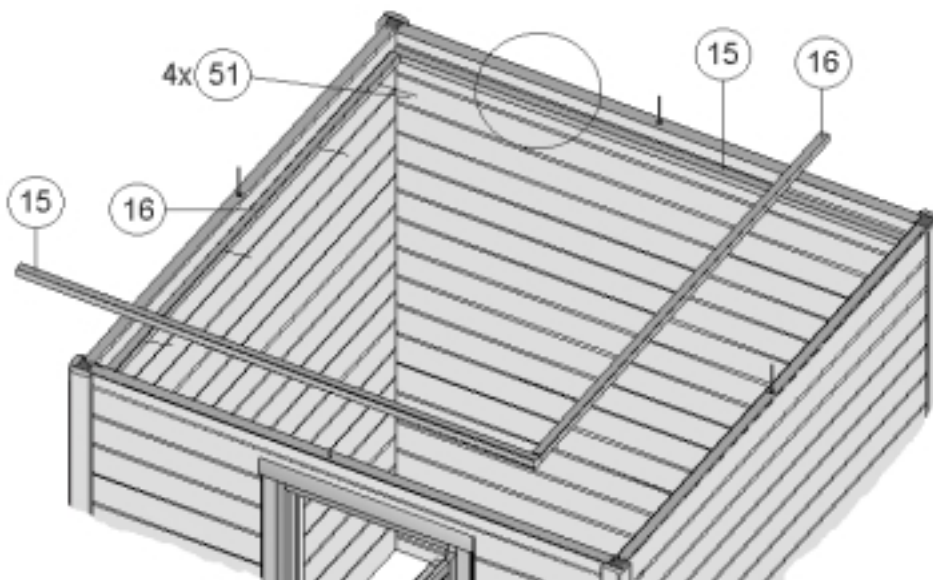
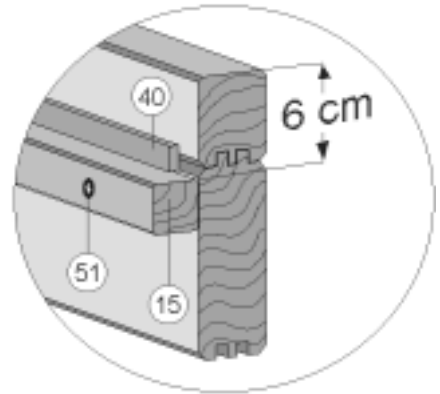

12

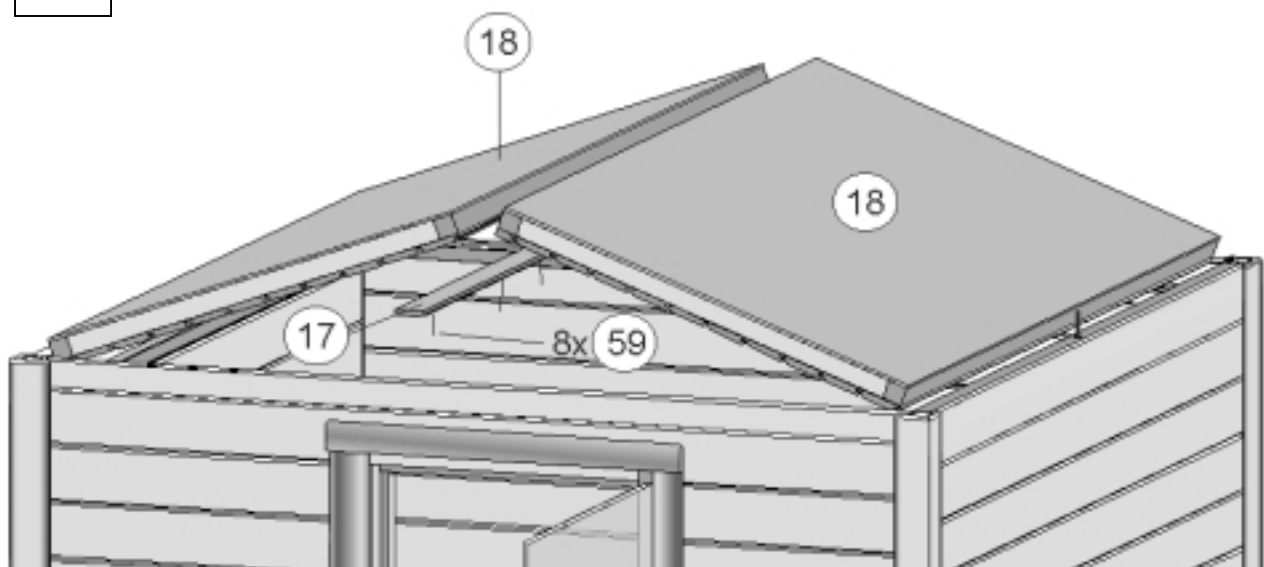

Liegenhalterung

GB	Reclining mounting
F	fixation de couchette
I	supporto sdraio
E	Soporte de litera
P	Suporte do divã

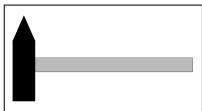
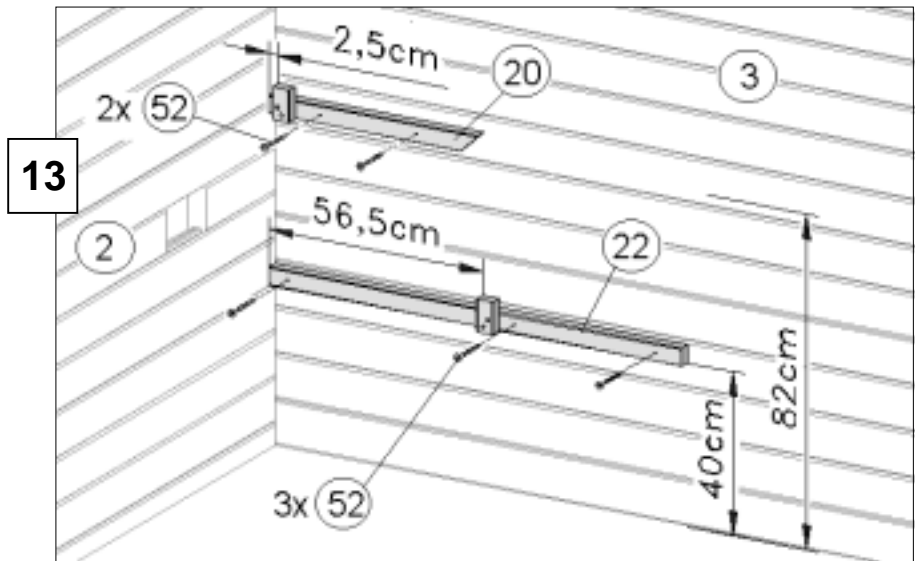
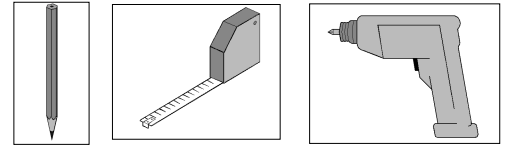

14

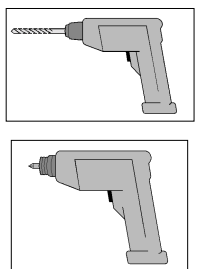
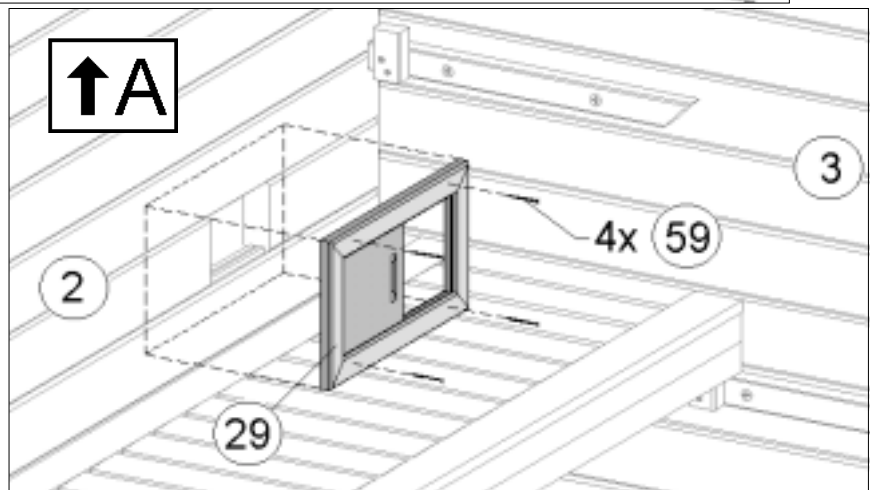

15

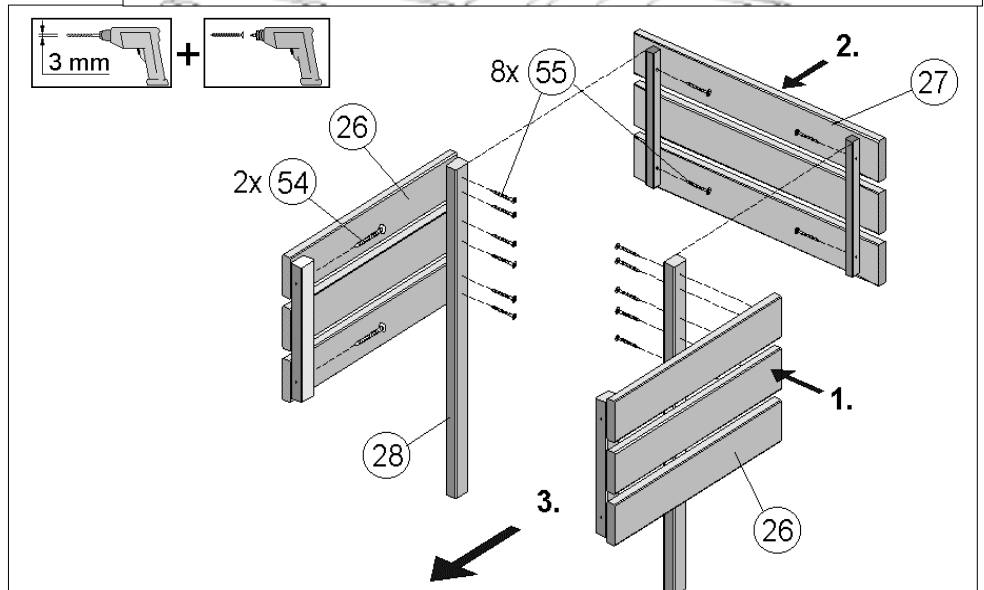

D	Ofenschutz
GB	Furnace protection
F	protection de poêle
I	protezione stufa
E	Protección estufa
P	Protecção do forno

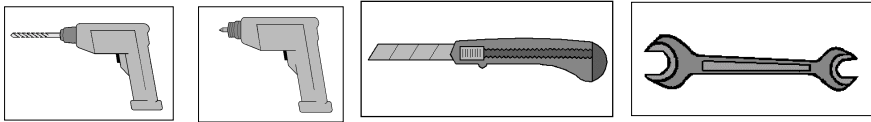

16

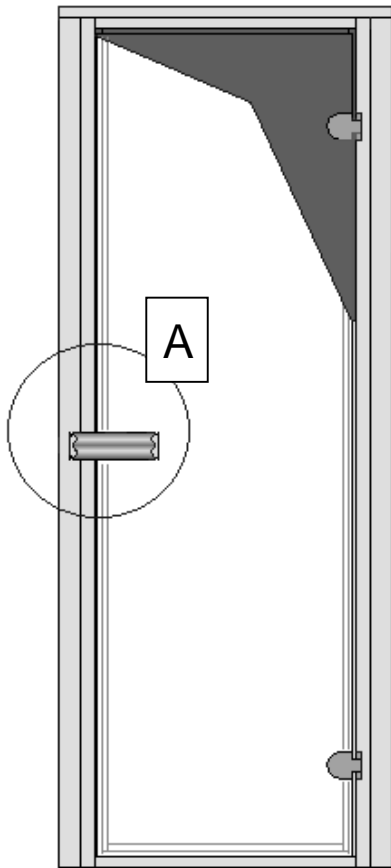

A-1

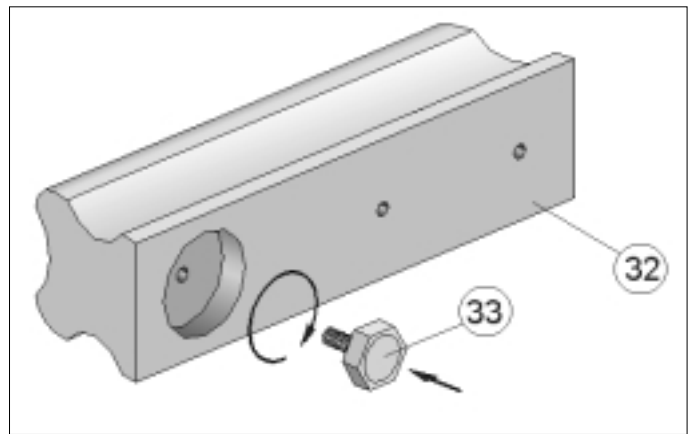

A-1

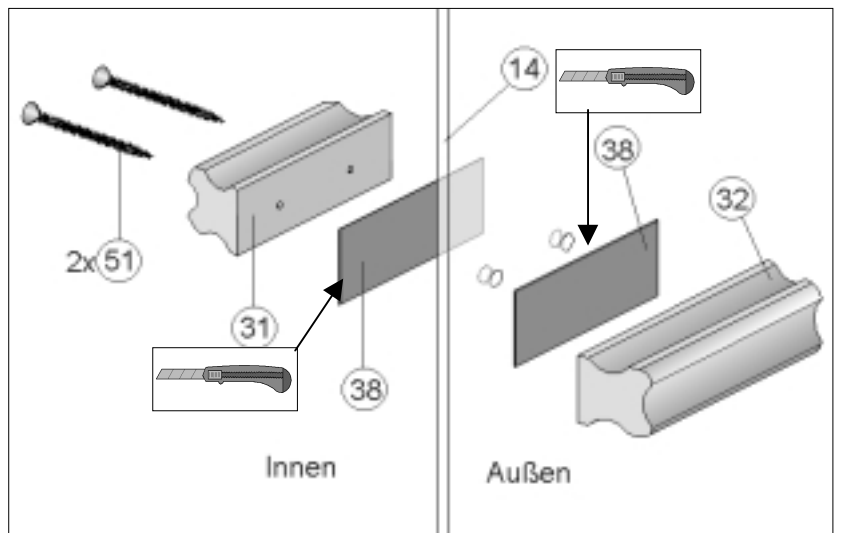

A-3

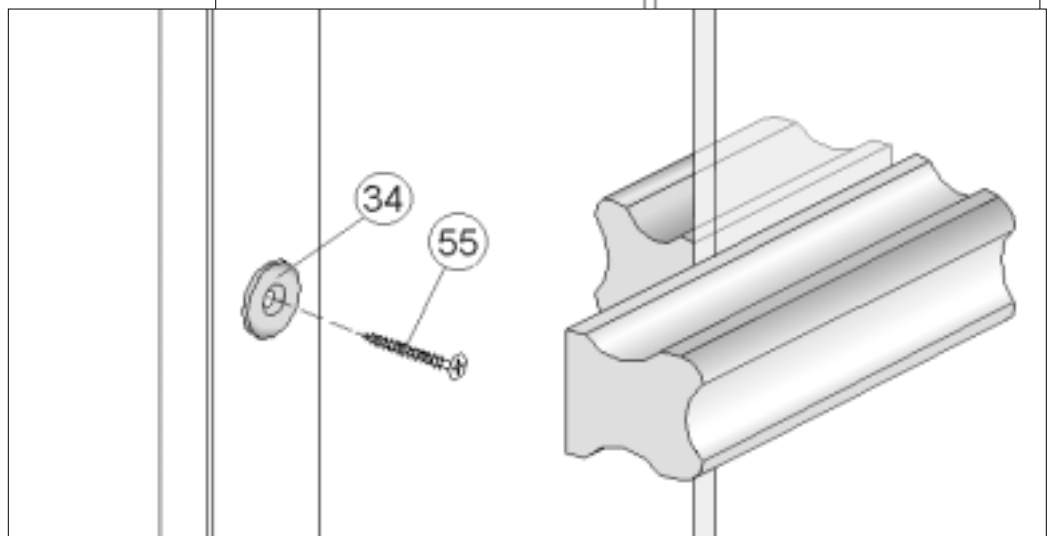

Ma Art.-Nr.: 800.0286.01.16