

FLEXA®

81-20102-1/-2/
-15/-16/-25/-26

57 x 36 x 43,5cm

Flexa Rollkommode 3 Schu.

Natur:
4048.378

Weiss:
4048.379

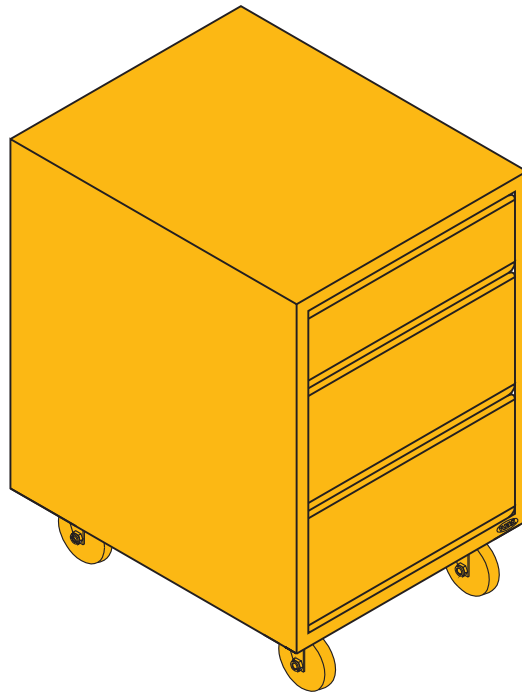

For indoor
domestic use

Monterings- og brugsvejledning

Assembly instructions and
directions for use

Montageanleitung und
Gebrauchsanweisung

Notice de montage et mode
d'emploi

Instrucciones de montaje y uso

Montageinstructie en onderhouds-
voorschrift

Istruzioni per montaggio e
uso



Danish Design made in Denmark

1/April 2008
44-00406



Møbler fra FLEXA er fremstillet af massivt træ, hvilket betyder at farve- og strukturforskelle er en naturlig del af møblet. Skulle der mod forventning opstå en reklamation, skal denne blanket udfyldes og returneres til FLEXA forhandleren. Venligst kontroller, at alle dele er komplette, inden montage påbegyndes.



Furniture from FLEXA is produced from solid wood, which means that colour and structure difference are a natural part of the furniture. However should a complaint occur, this form must be filled and returned to your FLEXA stockist. Please make sure that all parts are complete before you start assembling.



Die FLEXA Produkte werden aus massivem Kiefernholz hergestellt. Farbunterschiede sowie unterschiedliche Maserungen sind Naturmerkmale. Sollte es trotzdem Grund zur Reklamation geben, füllen Sie bitte diesen Schein aus und wenden Sie sich an Ihren FLEXA Händler. Kontrollieren Sie vor Montagebeginn den Artikel auf Vollständigkeit und Beschädigungen.

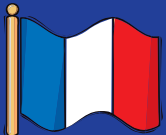

Les meubles FLEXA sont réalisés en pin massif. Certaines différences de teintes ou de structures peuvent apparaître : elles proviennent de la matière naturelle du bois. Si toutefois vous constatez une anomalie, merci de remplir la fiche ci-jointe et de la retourner à votre revendeur. Veuillez vérifier l'intégralité des pièces avant d'entreprendre le montage.



Los muebles de FLEXA están hechos de pino macizo, por lo cual pueden aparecer pequeñas diferencias en el tono y la estructura del mueble, formado de manera natural. Si en contra de lo previsto surge una incidencia, hay que rellenar este formulario y devolverlo al distribuidor. Les rogamos controlen que todas las piezas están completas antes de empezar el montaje.



De meubelen van FLEXA zijn gemaakt van massief hout hetgeen betekent dat kleur en structuurverschillen een natuurlijk onderdeel zijn van de meubelen. Mocht er desondanks een klacht ontstaan, vul dan dit formulier in en lever het in bij uw FLEXA dealer. Controleer of alle benodigde onderdelen aanwezig zijn voordat u begint met monteren.



I mobili della FLEXA sono prodotto in legno di pino massiccio, significa che si possano verificarsi piccole nocchii e gradazioni di colore e simili sulla superficie che fanno parte delle caratteristiche del legno naturale. Comunque per qualsiasi reclamo bisogna riempire il modulo e consegnarlo al Vostro rivenditore. Vi preghiamo di controllare che tutti i pezzi siano intatti prima di cominciare il montaggio.

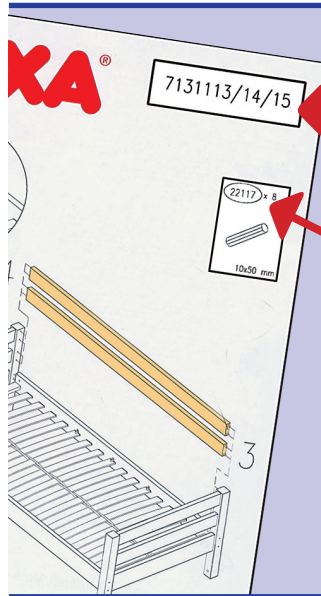

**Model nr. / Model No / Modell Nr. /
Modèle no / No Modelo / Artikel nr. /
Numero Modello**

**Emne nr. / Part / Teile-Nr. /
Pièce réclamée / No. pieza /
Onderdeelnummer / No. pezzo**

Årsag

1

Manglende del / Missing part/
Fehlendes Teil / Pièce manquante /
Falta pieza / Missende delen / Parte
mancante

Reason

Ursache

2

Fejl i træet / Defect in the wood /
Holzfehler / Défaut de bois /
Madera defectuosa / Fout in het
hout / Difetto nel legno

Motif

Motivo

Oorzaak

Motivo









3

Fejlboring / Faulty drilling
Falsche Bohrung / Défaut de
perçage
Taladro erróneo / Verkeerd geboord
Difetto forature

4

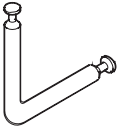
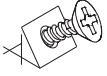
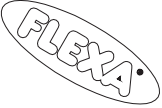
Fejl i lakken / Fault in lacquer
Fehler im Lack / Défaut de finition
Barniz defecto / Fout in de
lakafwerking / Difetto laccatura

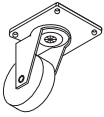

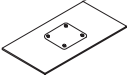
22269 x6  M4x12 mm	22014 x1  15 gr	3933-150121 x36  15x12,2 mm	22653 x12  20x40 mm
3934-07088 x12  47x47 mm	22848 x4  15x12,2 mm	28011 x1  15x12,2 mm	3934-06045 x12  6x45 mm
22095 x16  4x16mm PH	29281 x2 	29282 x2 	32403 x1 

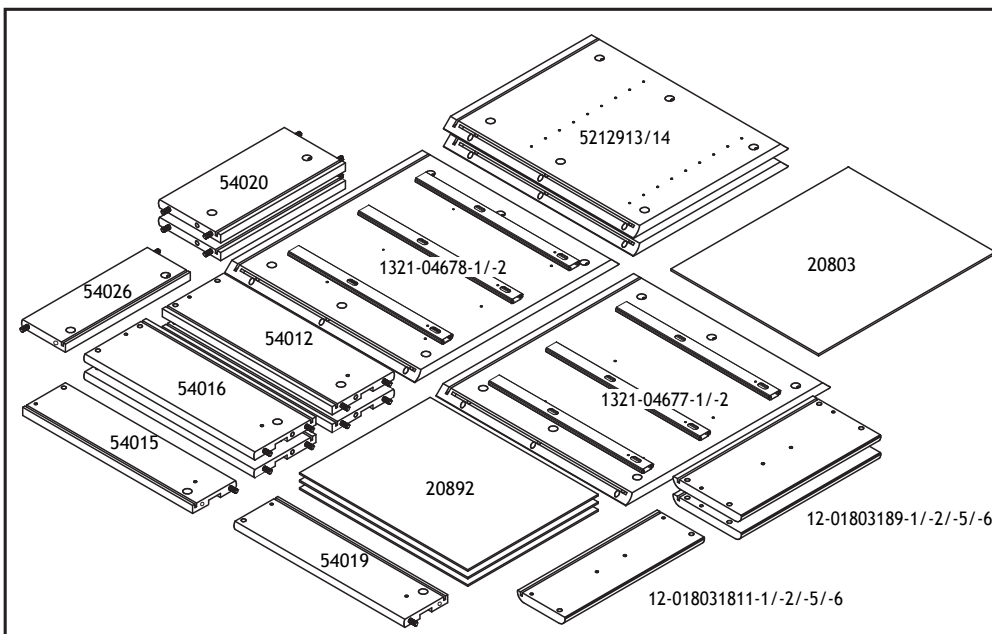
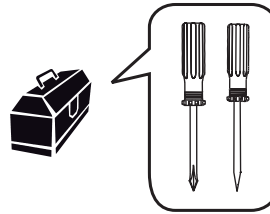

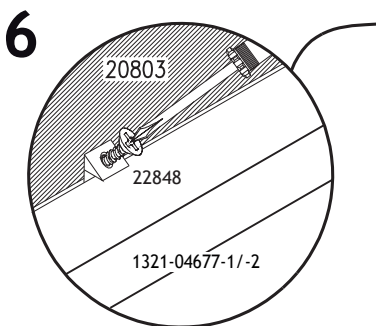
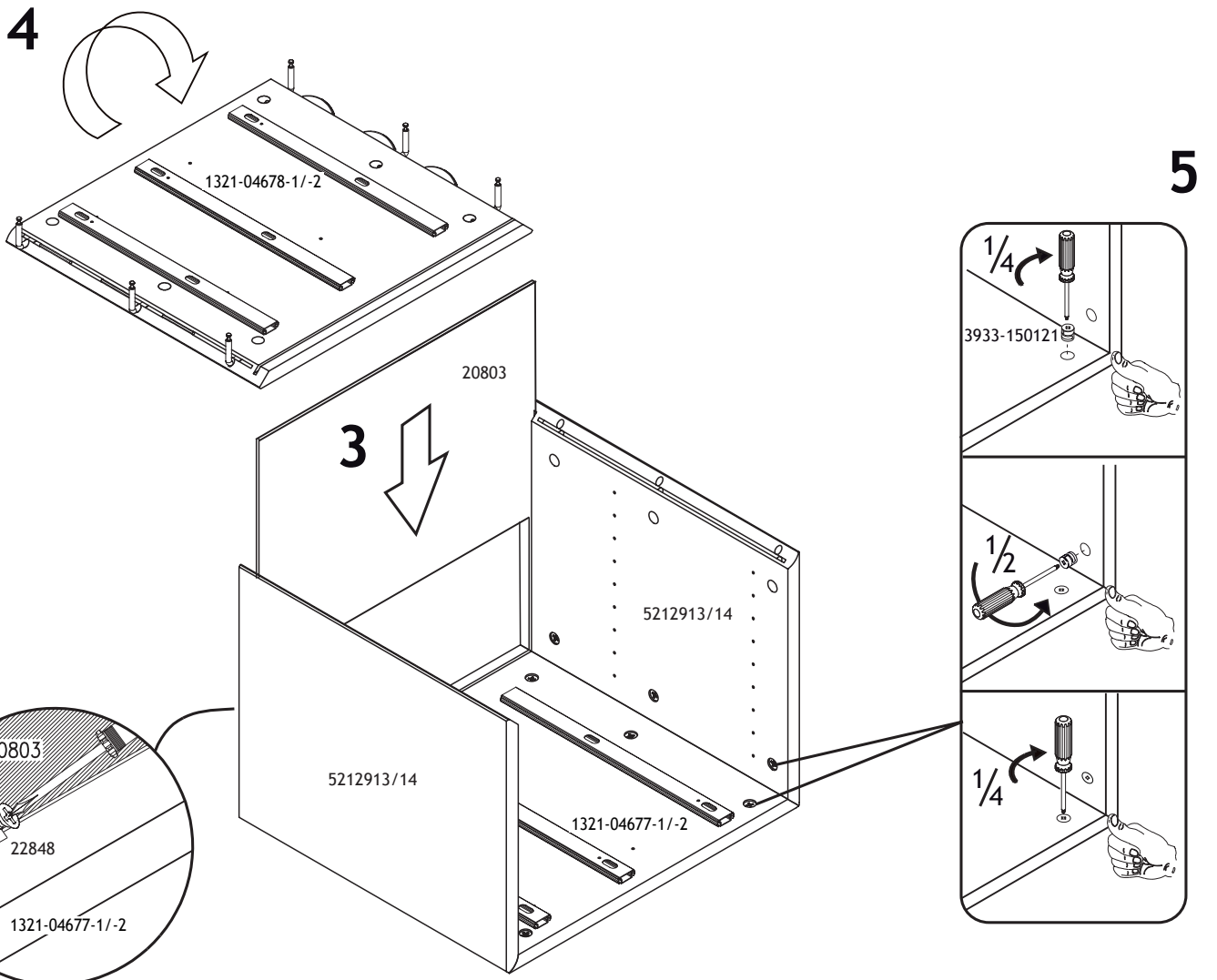
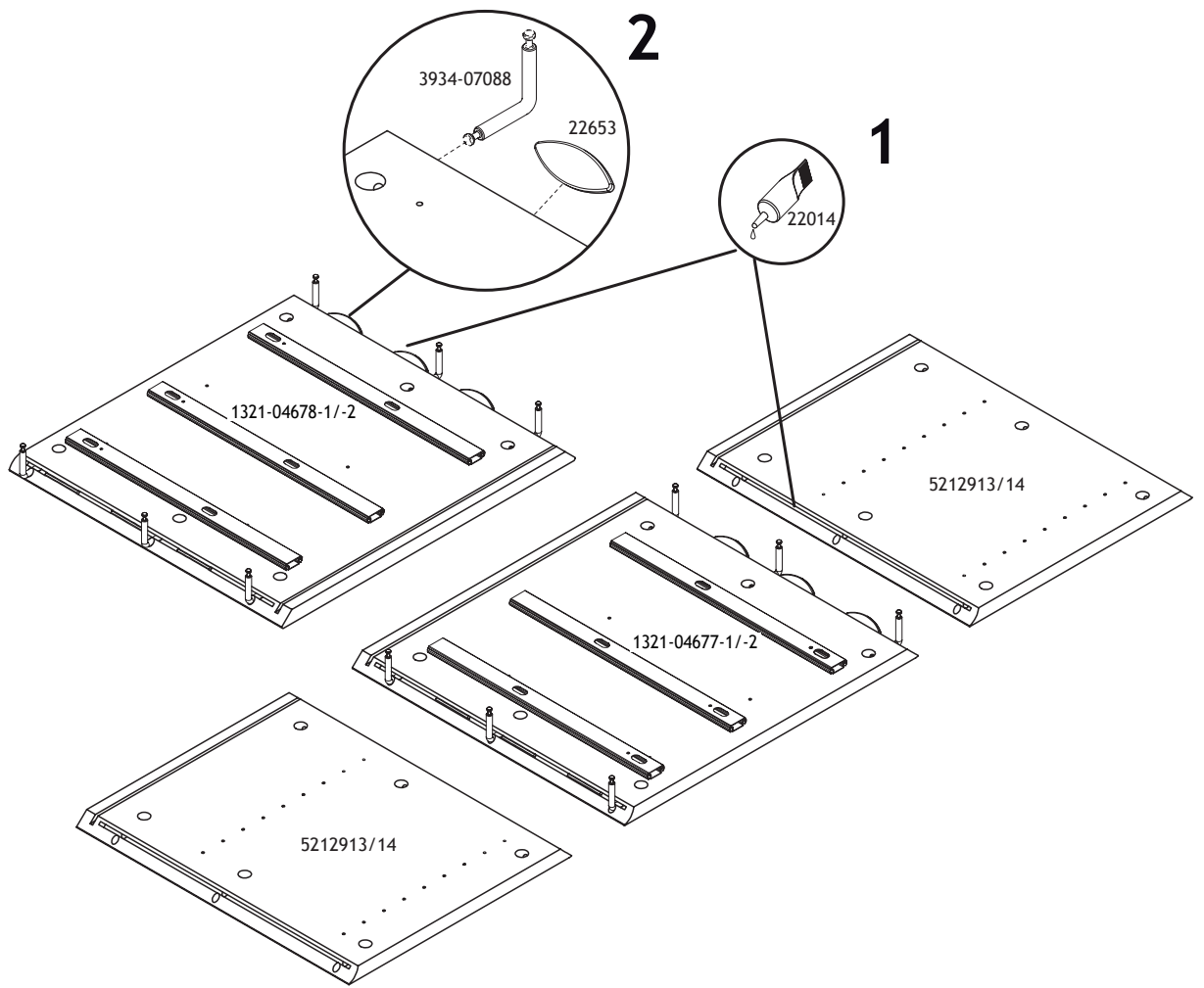

7

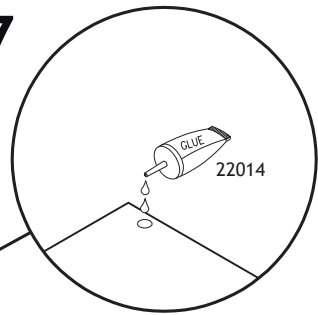

8

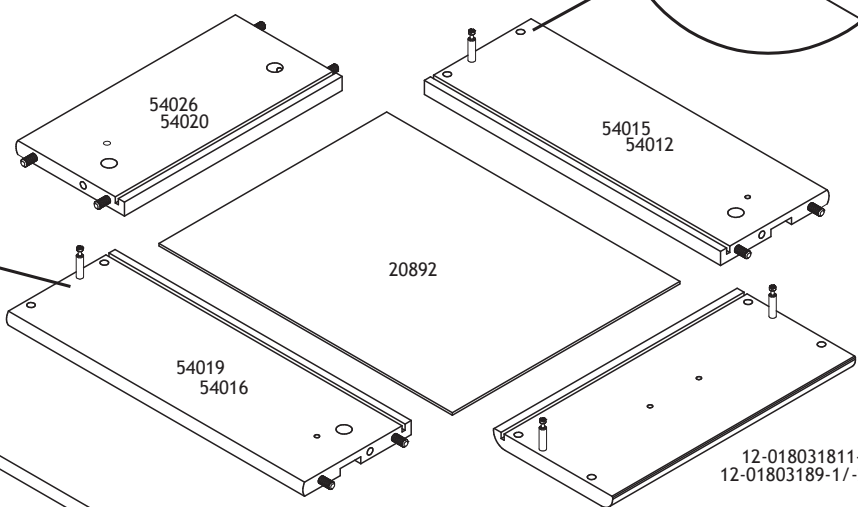
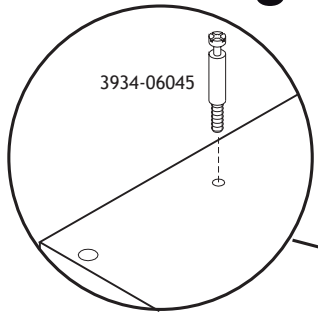

9

12-018031811-1/-2/-5/-6
12-01803189-1/-2/-5/-6

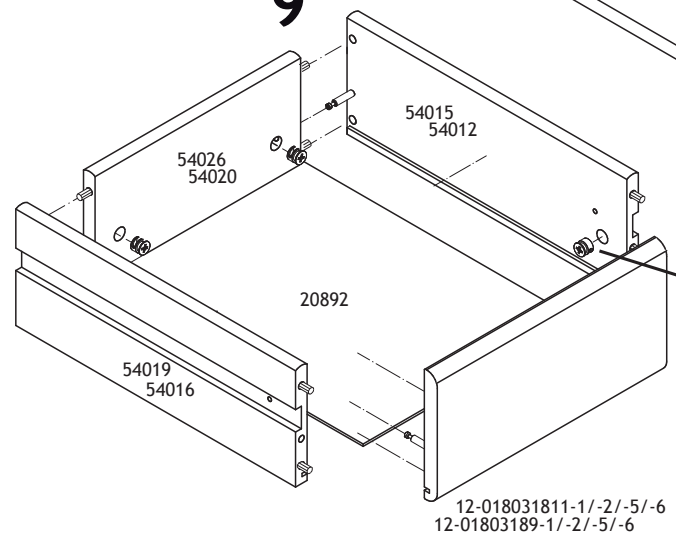

10

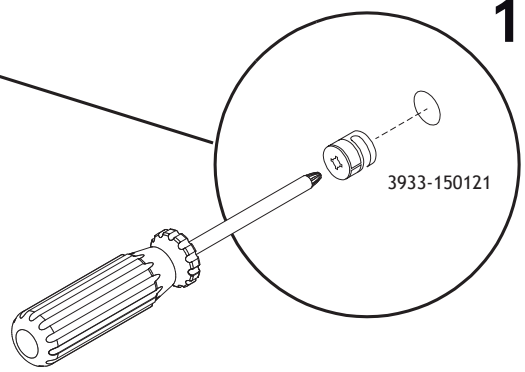

11

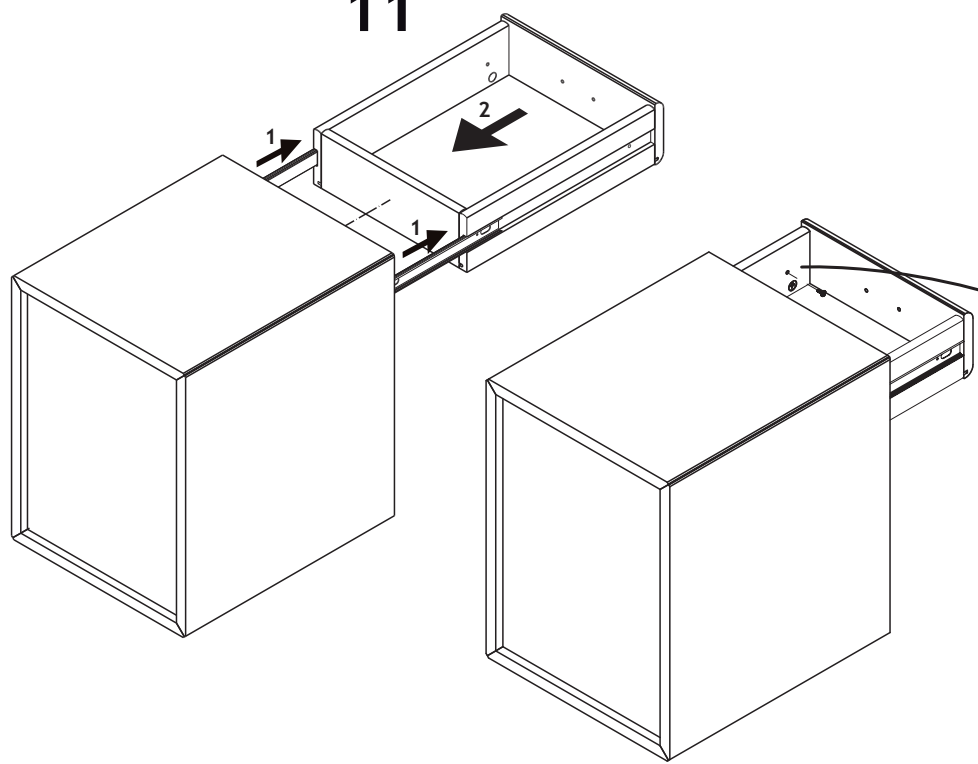

12

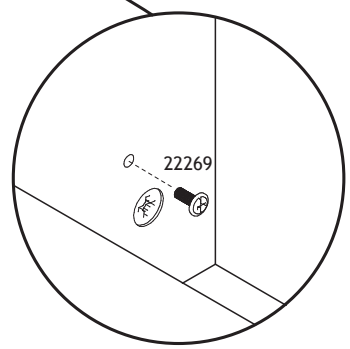

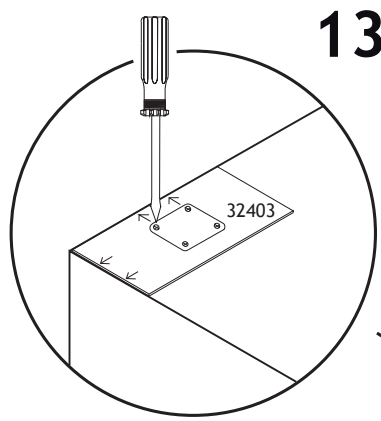

13

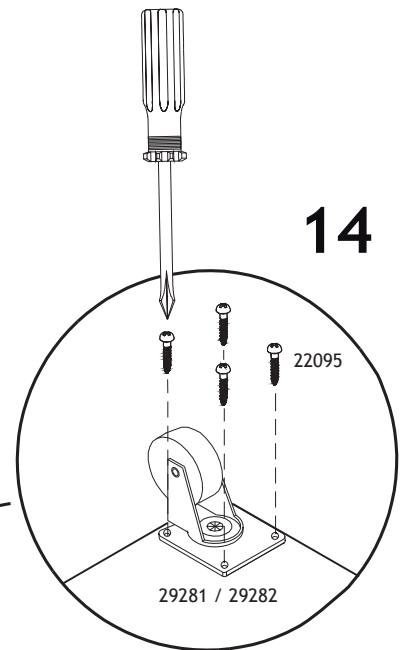

14

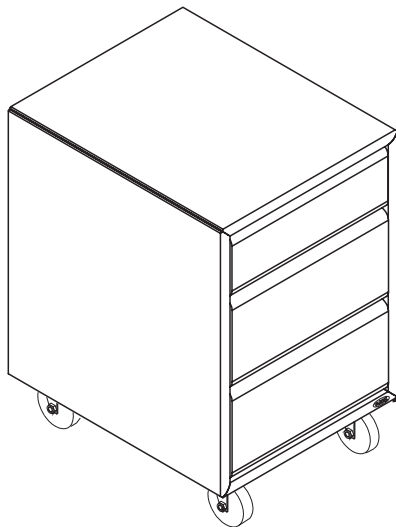
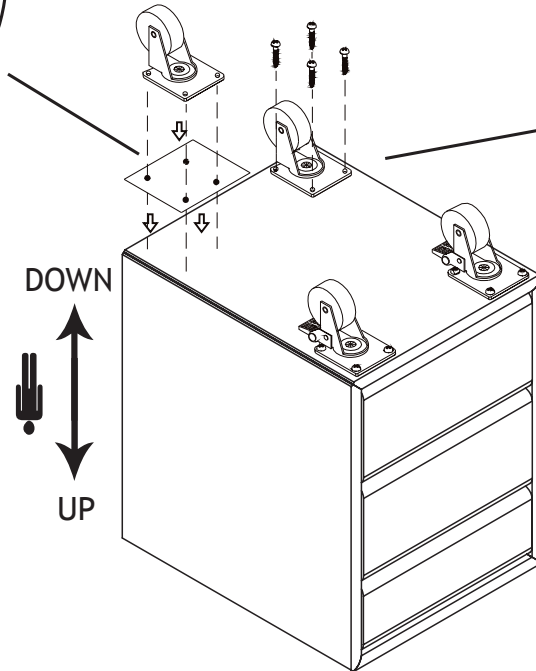

15

(DK)

RÅD OM VEDLIGEHOELSE:

Tør af med en fugtig klud. Evt. større pletter fjernes med en fugtig svamp med sæbe. Undgå opløsningsmidler. Skruer og bolte efterspændes med jævne mellemrum.

(GB)

MAINTENANCE INSTRUCTIONS:

Cleaning with a wet cloth, use a sponge with soap to remove obstinate dirt. Avoid solvents and dilutions. Screws and bolts should from time to time be retightened.

(D)

PFLEGEHINWEIS:

Pflege mit einem feuchten Lappen. Für hartnäckigen Schmutz empfehlen wir einen Schwamm mit Seife. Vermeiden Sie Lösungs- und Verdünnungsmittel. Schrauben und Bolzen sollten regelmässig nachgezogen werden.

(F)

CONSEILS D'ENTRETIEN:

Entretien avec un chiffon humide pour la poussière - les tâches rebelles s'enlèvent avec une éponge légèrement savonneuse. Eviter tous solvants et diluants. Votre lit doit être vérifié périodiquement afin de resserrer les vis.

(E)

CONSEJO PARA LA CONSEVACIÓN:

Limpiar con un paño húmedo. Para quitar manchas mas grandes usar una esponja con jabón. Evitar usar productos quimicos. Las herrajes necesitan opretarse a veces

(NL)

ONDERHOUD:

Reinigen met een vochtige doek. Hardnekkig vuil verwijderen met een spons en zeep. Vermijd oplos- en verdunningsmiddelen. Schroeven en moeren regelmatig aandraaien.

(I)

CONSIGLI PER LA MANUTENZIONE:

Pulire con un panno umido, usare una spugna impregnata di sapone per togliere lo sporco persistente. Evitare l'uso de prodotti chimici. Dadi e viti sono, di tanto e tanto, da ri-avvitare.