



SERVICEKARTE

KARTA SERWISOWA

Nie dotyczy klientów na terenie RP kartę serwisową zastępuje karta gwarancyjna.

D Sehr geehrter Kunde, sollte ein Teil fehlen oder beschädigt sein, kreuzen Sie bitte dieses deutlich auf **SERVICECARD** an und schicken Sie uns **SERVICECARD** zurück.

GB Dear customer, should there be any part missing or damaged, kindly mark this part clearly on the attached **SERVICE CARD** and return this **SERVICE CARD** to us.

F Cher client, Lorsque vous constatez qu'une pièce est manquante ou abimée, nous vous prions de bien vouloir la marquer d'une croix sur cette **SERVICE CARD** et de nous retourner cette **SERVICE CARD**.

PL Szanowny Kliencie, gdyby brakowało jakiejś części lub byłaby uszkodzona proszę to oznaczyć krzyżykiem na **SERVICE CARD** i przesłać **SERVICE CARD** razem z reklamacją.

BEST REGARDS
 Mit freundlichen Grüßen
 Ihr Schieder-Team

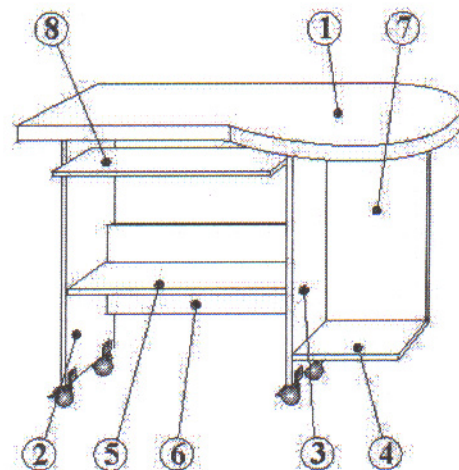
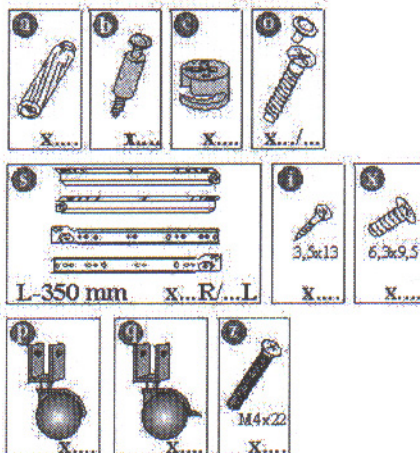

Nicht vergessen/Nie zapomnieć

Absender/Nadawca:

Kaufvertrag Serie:
 Lieferschein-Nr:
 Nr dowodu sprzedaży:

Datum/Data:

Fehlerbeschreibung
 Wykaz wad:

.....

.....

.....

.....

.....

.....

.....

.....

40-091 / RONDA I 4017.070

1

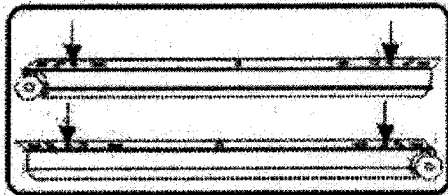
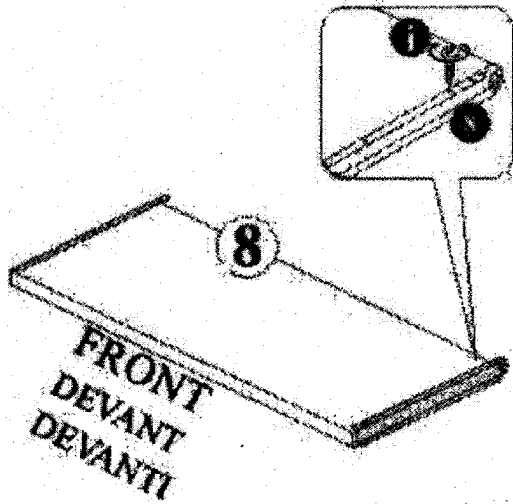
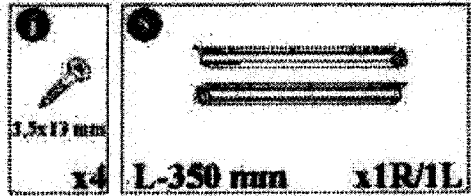

2

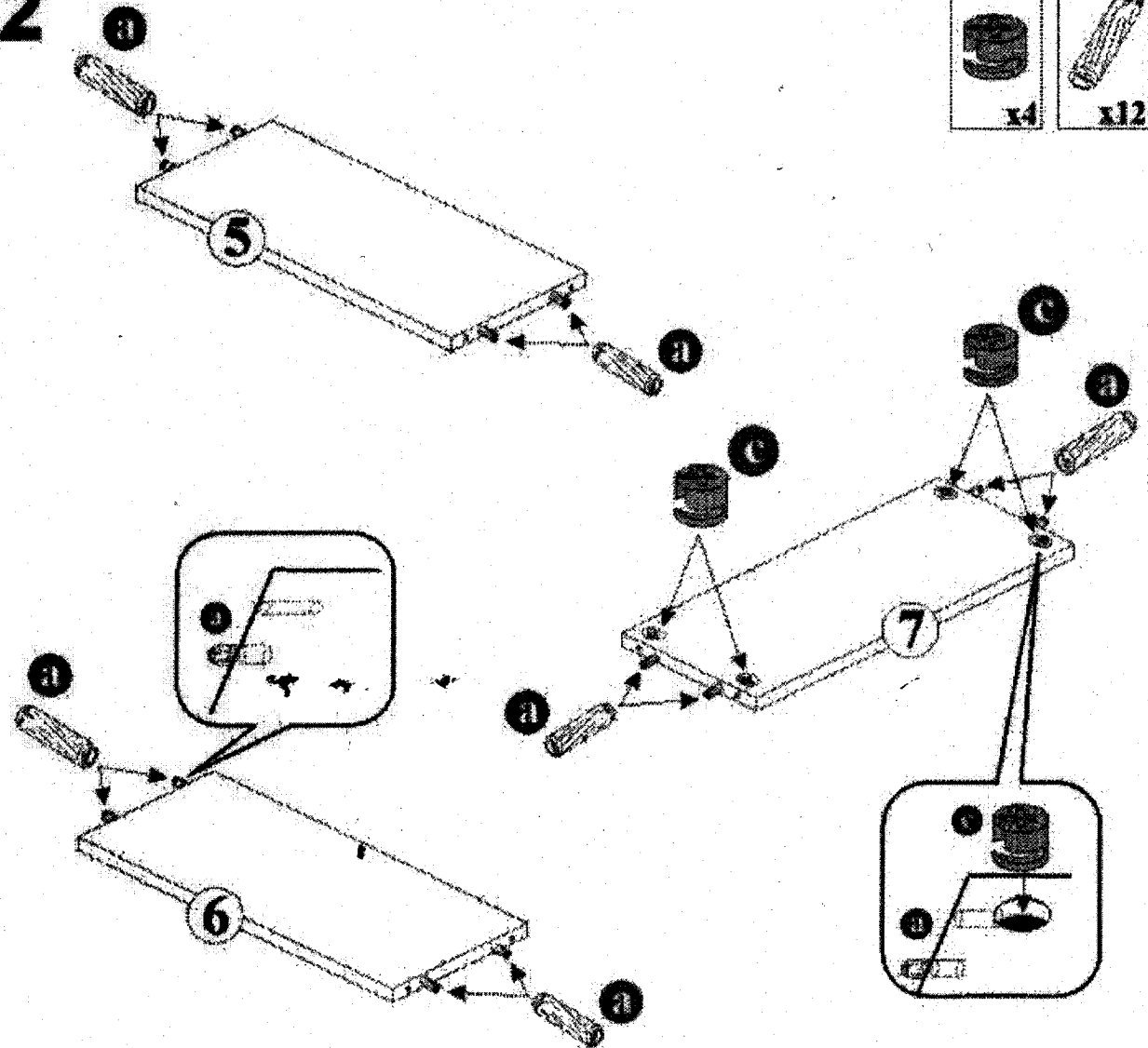
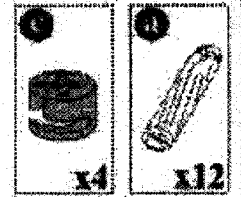

40-091 / RONDA I 4017.070

3

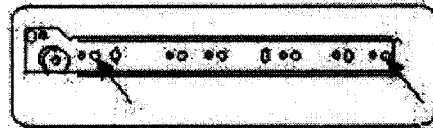
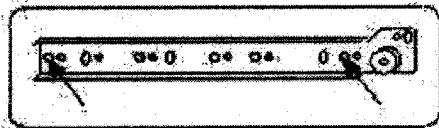
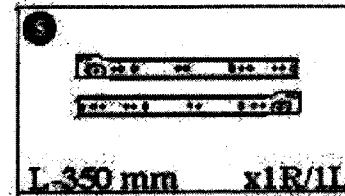
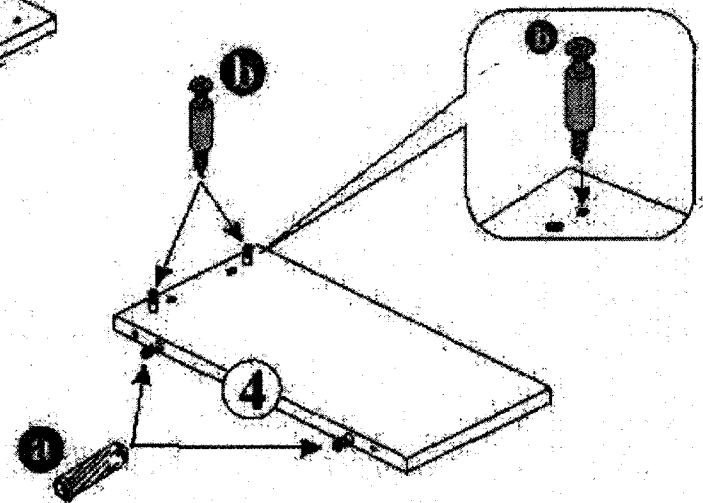
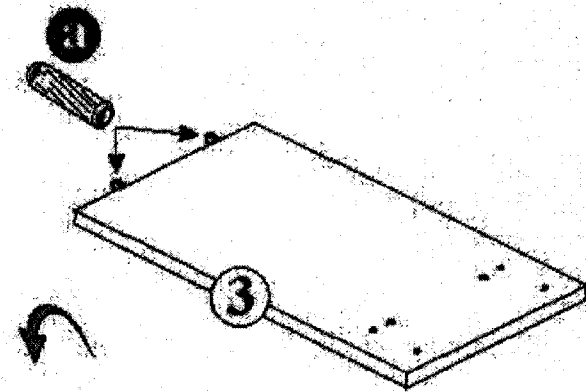
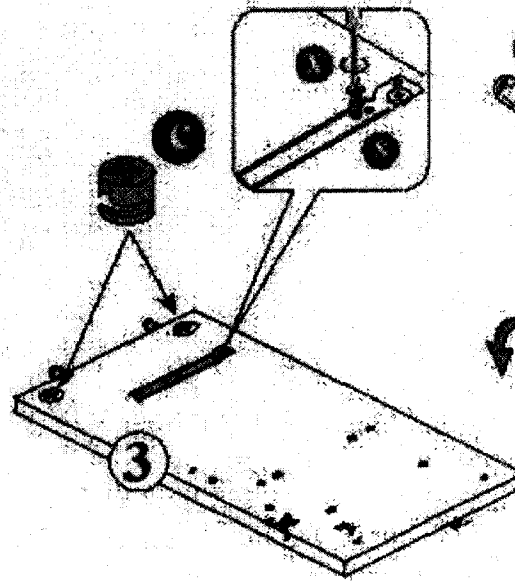
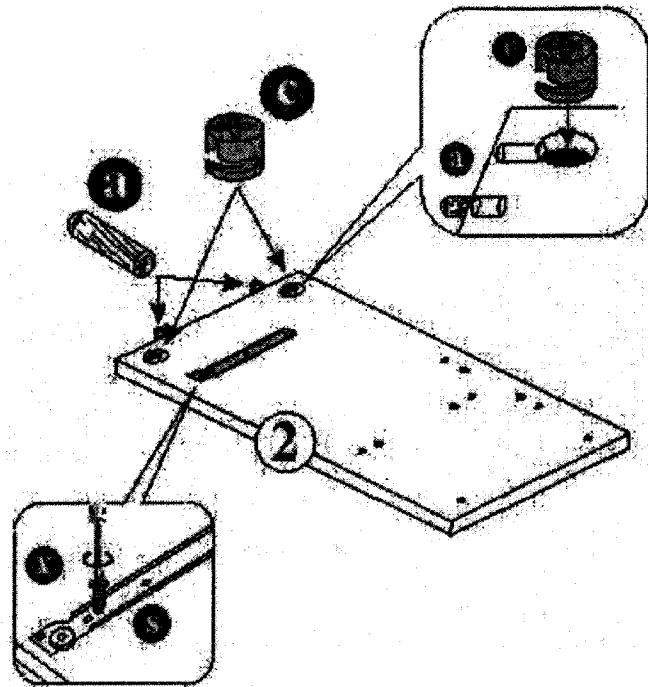

40-091 / RONDA I 4017.070

4

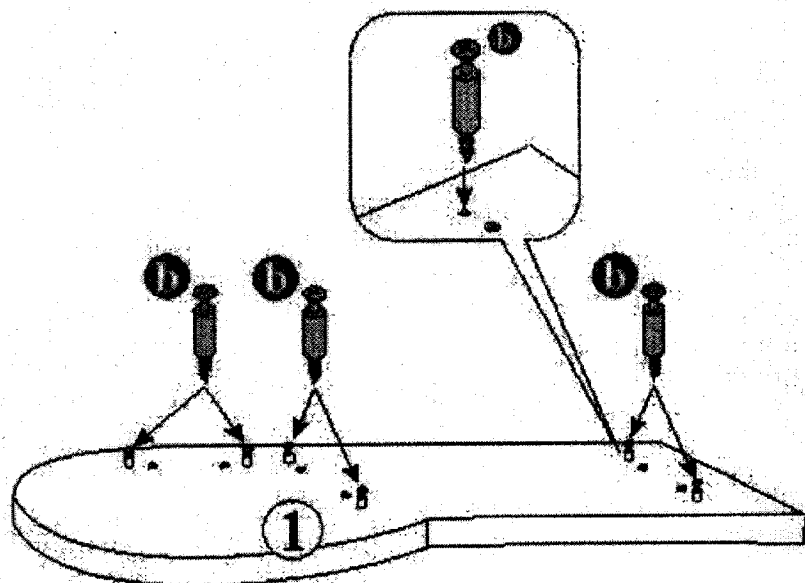

5

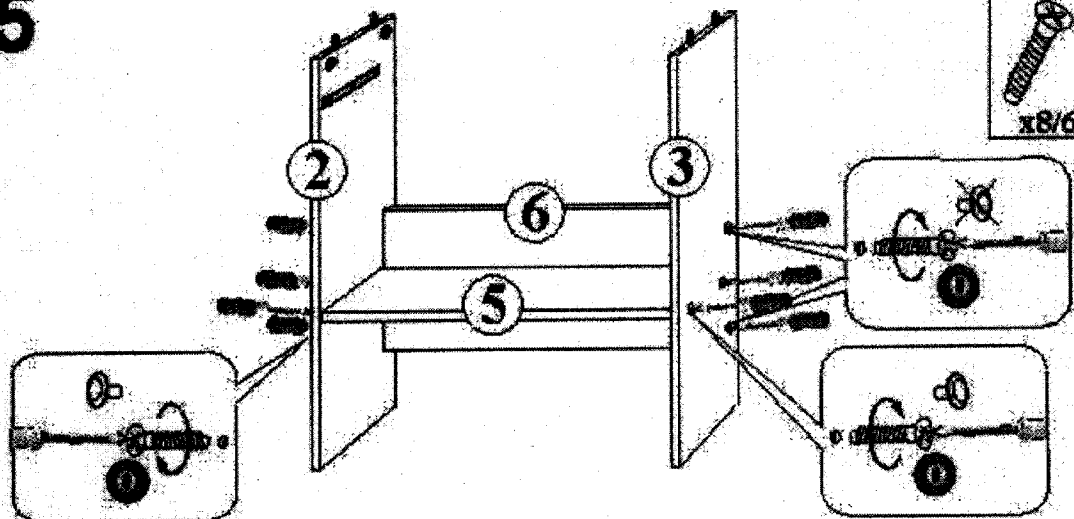

6

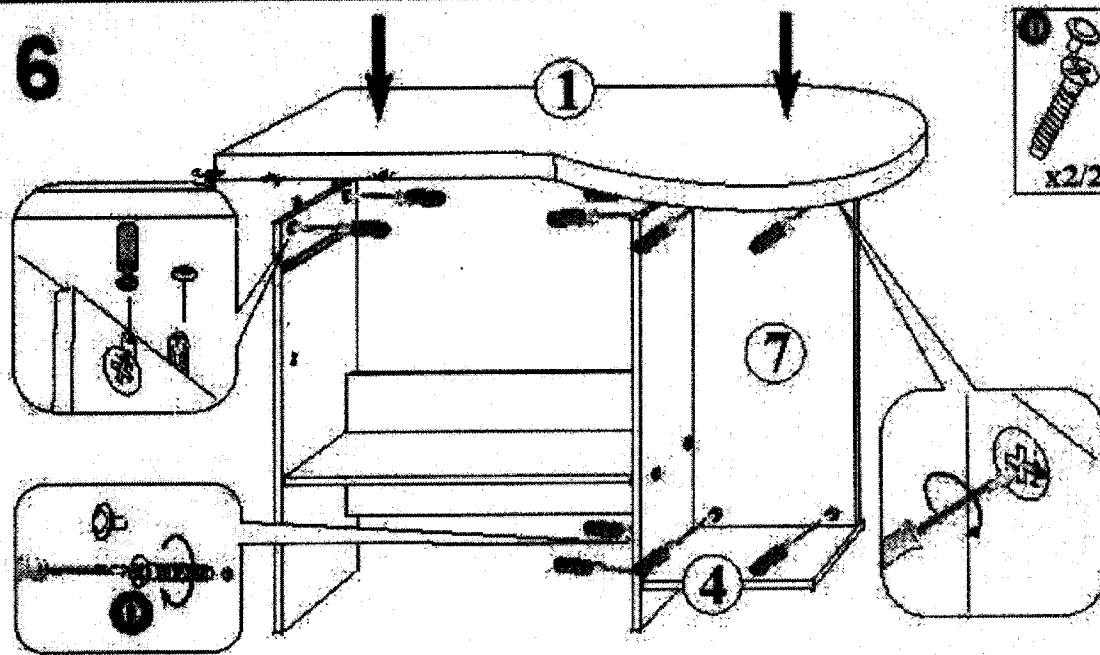

7

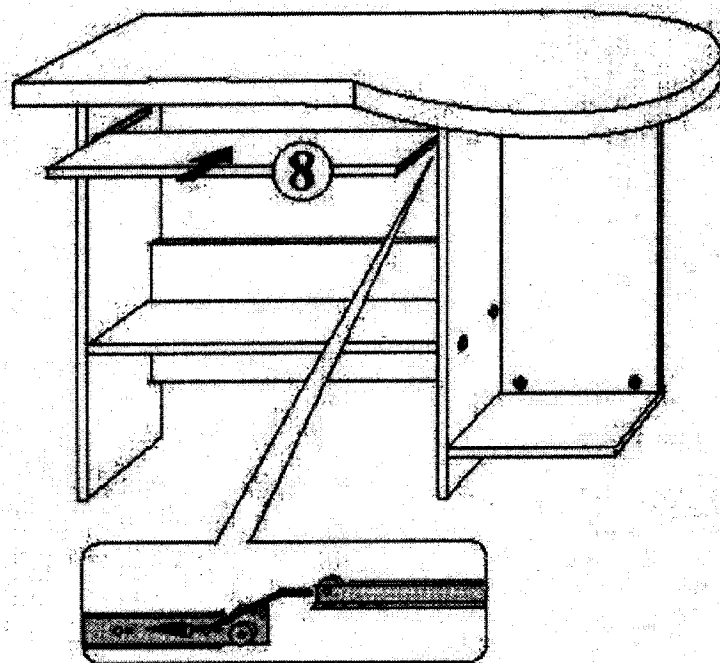

8

