Wichtig:
Vor Gebrauch sorgfältig durchlesen/
Montageanleitung für späteres Nachlesen aufbewahren

Important:
Lisez attentivement/
conserver les instructions d'installation pour référence future avant utilisation

Importante:
lettura/conservare istruzioni per l'installazione per riferimento futuro accuratamente prima dell'uso

Important:
Read carefully before assembling/keep and store Instruction for reference

JULES

6 DRAWER TALL CHEST
40445950000

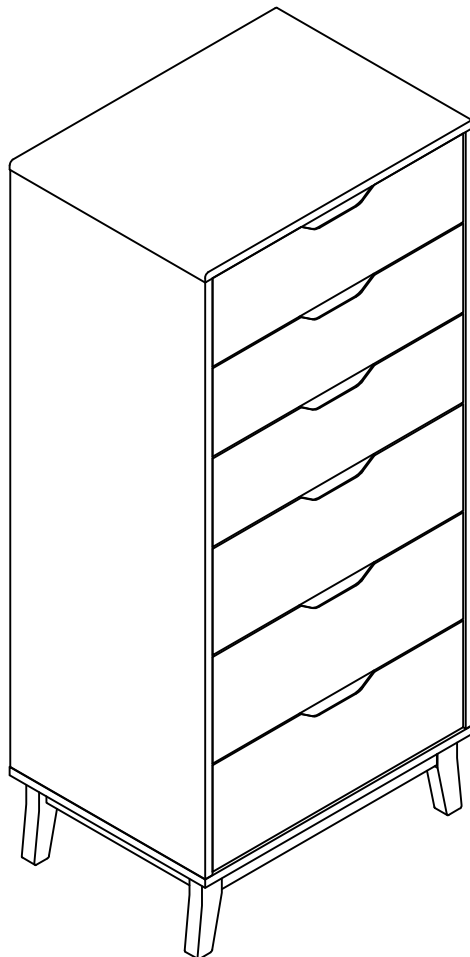



Warnhinweise

Bestimmungsgemässer Gebrauch:

Bitte achten Sie darauf, dass Ihre Möbel nur Ihrem Zweck gemäss verwendet werden. Für eine dauerhafte Funktionsfähigkeit ist eine sachgerechte Nutzung und regelmässige Unterhaltspflege sehr wichtig.

Mises en garde Avvertenze

Utilisation conforme:

Veillez vous assurer que vos meubles sont utilisés uniquement pour leur usage prévu. Un entretien régulier et une utilisation conforme sont essentiels pour assurer un fonctionnement durable.

Utilizzo per lo scopo previsto:

assicuratevi che i vostri mobili siano utilizzati solo per lo scopo per cui sono stati realizzati. Per garantire il loro funzionamento nel tempo è importante utilizzarli correttamente e sottoporli regolarmente a cure manutentive.

Warning notice

Intended use:

Please make sure that you only use your furniture for the purpose it was designed for. Correct use and regular maintenance are essential for ensuring your furniture remains in working order for the long-term.

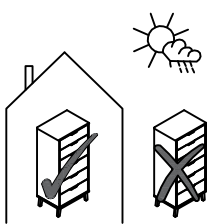

Anwendung:

Das von Ihnen erworbene Bett eignet sich für den allgemeinen, privaten Wohnbereich. Es ist nicht für den Nass-, Aussen- oder gewerblichen Bereich geeignet.

Usage:

Le lit que vous avez acheté convient pour l'habitat privé en général. Il ne convient pas pour l'extérieur, les milieux humides ou le domaine commercial.

Impiego:

il letto acquistato è adatto per essere utilizzato in generale, in ambito domestico. Non è adatto per gli esterni, per l'esposizione alla pioggia o per ambienti commerciali.

Area of use:

The bed you have purchased is suitable for use in general private living quarters. It is not suitable for areas that are wet, outside or used for commercial purposes.



WARNUNG

Verschluck- und Erstickungsgefahr:

Kleinteile und Verpackungsmaterial können verschluckt werden.

AVERTISSEMENT

Risque d'ingestion et d'étouffement:

Les petites pièces et le matériel d'emballage peuvent être avalés.

AVVERTENZA

Pericolo di ingestione e soffocamento:

piccole parti e materiale di imballaggio possono essere ingerite.

WARNING

Risk of swallowing and choking:

Small parts and packaging material may be swallowed.

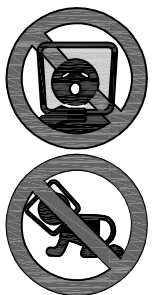

WARNUNG! Tüten und Folien sind kein Spielzeug! Bitte von Babys und Kleinkindern fernhalten! Nicht über den Kopf ziehen; Erstickungsgefahr!

AVERTISSEMENT! Les sacs et films ne sont pas des jouets! Veuillez les tenir hors de portée des bébés et jeunes enfants! Ne pas mettre sur la tête, risque d'étouffement!

AVVERTENZA! Sacchetti e pellicole non sono un giocattolo! Tenere lontano dalla portata dei neonati e dei bambini piccoli! Non metterli in testa, pericolo di soffocamento!

WARNING! Bags and film coverings are not toys! Please keep away from babies and small children! Do not put them over your head, risk of suffocation!



Warnhinweise

Mises en garde Avvertenze

Warning notice



**VORSICHT,
Verletzungsgefahr:**

Kleinkinder dürfen sich nicht im Montage-Bereich aufhalten und an Möbeln hochziehen oder hinaufklettern.

**PRÉCAUTION,
risque de blessures:**

Les jeunes enfants ne peuvent pas se tenir dans la zone de montage ni tirer ou grimper sur des meubles.

**PRECAUZIONE,
pericolo di lesioni:**

tenere i bambini lontano dal luogo di montaggio e evitare che si appendano o arrampichino sul mobile.

**PRECAUTION,
risk of injury:**

Small children must keep away from the assembly area. They must refrain from climbing up on the furniture.

1.	Allgemeine Hinweise	Remarques générales	Avvertenze generali	General information
----	----------------------------	----------------------------	----------------------------	----------------------------

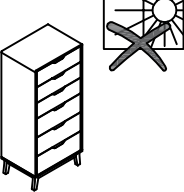
	<p>ACHTUNG Direkte Sonneneinstrahlung: Führt zu Farbveränderungen.</p>	<p>ATTENTION Exposition directe au soleil: Provoque des décolorations.</p>	<p>ATTENZIONE Irraggiamento diretto del sole: ne modifica il colore.</p>	<p>ATTENTION Direct sunlight: results in discolouration.</p>
---	--	--	--	--

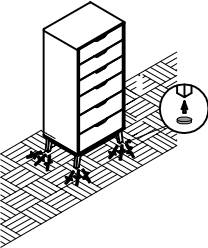
	<p>Schutzgleiter: Mit Schutzgleitern (z.B. aus Filz), lassen sich Schäden auf kratzempfindlichen Böden (z.B. Parkett) vermeiden.</p>	<p>Patins: Les patins (p.ex. en feutre) permettent d'éviter d'endommager les sols sensibles aux rayures (p.ex. parquet).</p>	<p>Scivolante protettivo: grazie agli scivolanti protettivi (ad es. feltro) si evita di danneggiare pavimenti sensibili ai graffi (ad es. parquet).</p>	<p>Protective covers: Protective covers, e.g. felt pads, prevent damage to floors that are easily scratched (e.g. parquet).</p>
--	---	---	--	--

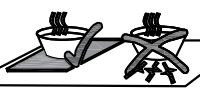
	<p>ACHTUNG, Temperatur: Nie heiße oder sehr kalte Objekte direkt auf die Oberfläche stellen. Geeigneten Schutz verwenden, z.B. Untersteller.</p>	<p>ATTENTION, température: Ne jamais poser des objets chauds ou très froids directement sur la surface. Utiliser une protection appropriée, p.ex. sous-plat.</p>	<p>ATTENZIONE, temperatura: non appoggiare mai oggetti caldi o molto freddi direttamente sulla superficie. Utilizzare una protezione adatta, ad es. un sotto piatto.</p>	<p>ATTENTION, temperature: Do not place hot or cold objects directly on the surface. Use the appropriate protection, e.g. saucer.</p>
---	---	---	---	--

	<p>ACHTUNG Leder/Stoff: Schützen Sie das Leder/den Stoff vor scharfen Gegenständen (Schlüssel, Gurtschnallen, ecc.).</p>	<p>ATTENTION Cuir/tissu: protégez le cuir/tissu des objets coupants (clés, boucles de ceinture ecc.)</p>	<p>ATTENZIONE Pelle/tessuto: proteggere la pelle/il tessuto da oggetti taglienti (chiavi, fibbie, ecc.)</p>	<p>ATTENTION Leather/fabric: Protect the leather/fabric against sharp objects (e.g. keys, belt buckles, etc.)</p>
---	--	--	---	---

1.	Allgemeine Hinweise	Remarques générales	Avvertenze generali	General information
----	---------------------	---------------------	---------------------	---------------------

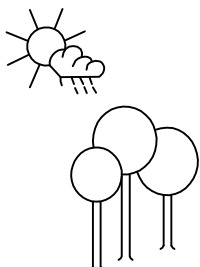

Holzprodukte:

Holz ist ein natürlicher Rohstoff. Jeder Baum ist abhängig vom Standort verschiedenen Einflüssen, wie Klima etc., ausgesetzt. Durch diese Einflüsse wird das Erscheinungsbild (Farbe, Äste, Maserung etc.) des Holzes massgeblich beeinflusst. Abhängig von der Luftfeuchtigkeit und Temperatur, hat Holz die Eigenschaft, sich auszudehnen und kleiner zu werden. Dies kann zu Rissen führen.

Veränderungen und Naturmerkmale sind natürlich und dadurch ist jedes Massivholzmöbelstück ein Unikat.

Produits en bois:

Le bois est une matière naturelle. Chaque arbre est exposé à diverses influences, comme le climat etc., en fonction de son lieu de plantation. L'aspect du bois (teinte, noeuds, grain etc.) est fortement conditionné par ces influences. Le bois a la propriété de se dilater ou de se rétracter en fonction de l'humidité et de la température. Cela peut provoquer des fissures.

Ces caractéristiques naturelles et les changements sont normaux, ce qui fait de chaque meuble en bois une pièce unique.

Prodotti di legno:

il legno è una materia prima naturale. Ogni albero, a seconda del luogo in cui cresce, è esposto a diverse influenze come il clima, ecc. Grazie a questi agenti, l'aspetto (colore, rami, venatura, ecc.) del legno viene fortemente influenzato. A seconda dell'umidità dell'aria e della temperatura, il legno ha la capacità di espandersi e ritirarsi. Questo può portare alla formazione di crepe.

La trasformazione e le caratteristiche sono naturali e, pertanto, ogni mobile di legno massiccio è unico nel suo genere.

Wooden products:

Wood is a natural raw material. Each tree is subjected to a whole variety of influences, e.g. the climate, depending on its location. These influences are decisive in creating the way the wood ultimately looks (colour, knots, grain, etc.). Depending on the humidity and temperature, wood is capable of expanding and contracting. As a result cracks may form.

Changes and natural characteristics are natural, so each piece of solid wood furniture completely unique.

2.

Montagehinweise

Instructions de montage

Istruzioni di montaggio

Assembly information

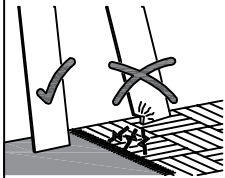

Montageschäden:

Vermeiden Sie, indem Sie einen sauberen und weichen Untergrund verwenden (z.B Teppich). Teile beim Auspacken oder während der Montage nur auf weiche Unterlagen legen/stellen. Darauf achten, dass grössere Teile nicht kippen können.

Domages au montage:

Évitez les dommages en utilisant un fond propre et doux (p.ex. tapis). Lors du déballage et montage, posez/placez les éléments uniquement sur un fond doux. Assurez-vous que les grands éléments ne peuvent pas basculer.

Danni in fase di montaggio:

evitare di causare danni utilizzando una base pulita e morbida (ad es. tappeto). Nella fase di disimballaggio e durante il montaggio, appoggiare i pezzi esclusivamente su una base morbida. Fare attenzione che i pezzi più grandi non si ribaltino.

Damages during assembly:

These can be avoided if you use a clean soft surface (e.g. carpet). Only place parts on a soft surface when unpacking or during the assembly. Make sure that larger parts cannot tip over.



Personen:

Für die Montage erforderliche Anzahl Personen.

Personnes:

Nombre de personnes nécessaires au montage.

Persone:

numero di persone necessarie per il montaggio.

People:

Number of people required for the assembly.



Montagerichtzeit:

Ungefähre Zeit in Stunden.

Durée indicative du montage:

Durée approximative en heures.

Tempo di montaggio:

tempo in ore approssimativo.

Assembly time:

Approximate time in hours.

Benötigtes Werkzeug:

Outils nécessaires:

Attrezzi necessari:

Tools required:

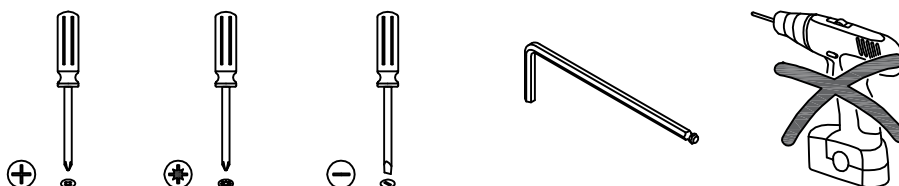

2.

Montage-
hinweise

Istruzioni de
montage

Istruzioni di
montaggio

Assembly
information

Bau-/Kleinteile:

Éléments/pièces:

Componenti/
piccoli pezzi:

Components/
small parts:

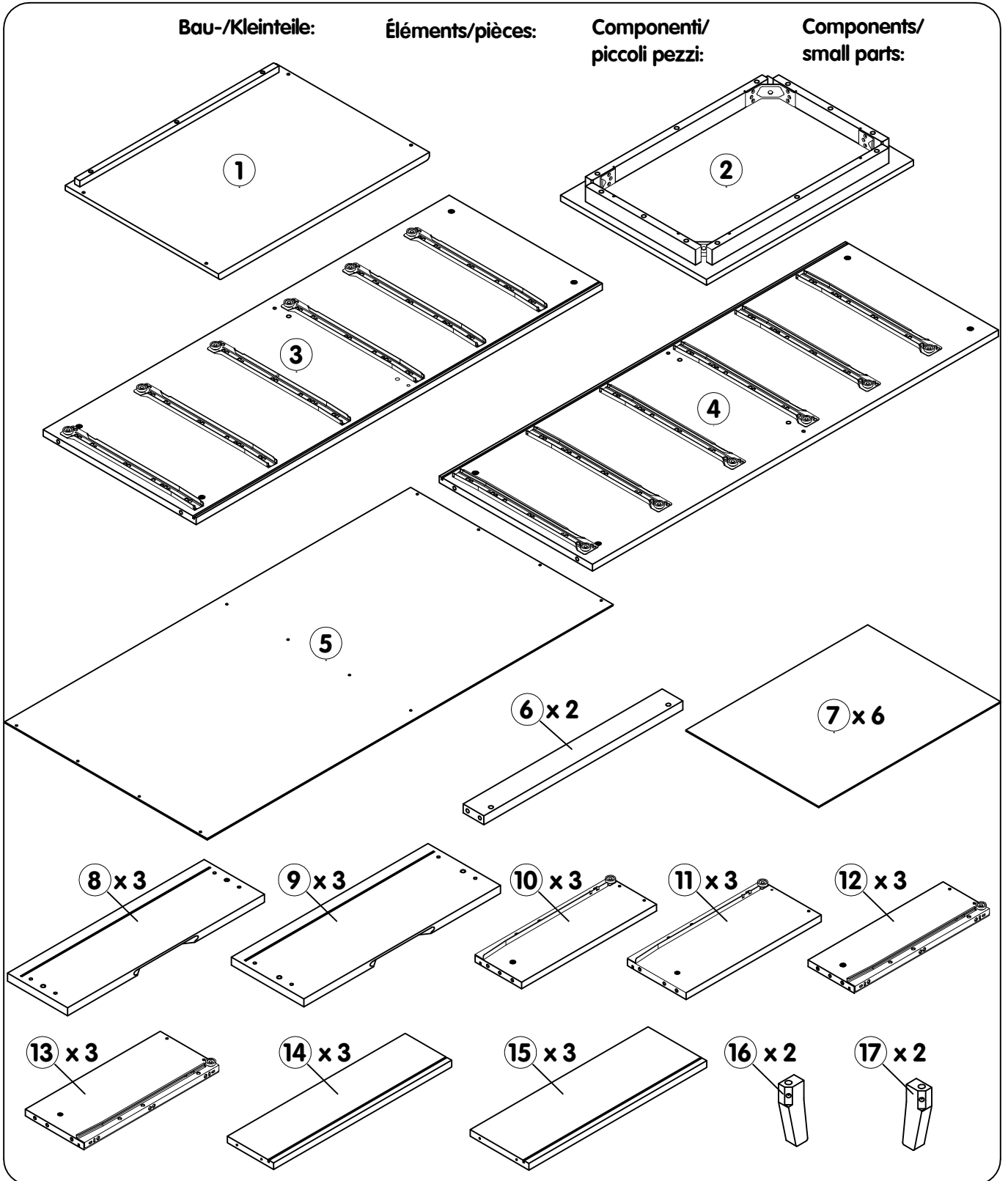



Ø7x70

4x

A

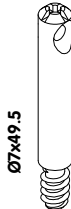

Ø7x49.5

4x

B



'O'-ring

12x

C



Ø8x30

4x

D

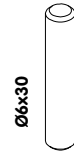

Ø6x30

24x

E



4x

F

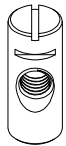

4x

G



4x

H



Ø8x8.5

8x

K



Ø7x7.5

12x

L

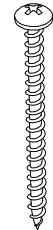

24x

M



12x

N



4x

P



4x

Q



4x

R



4x

S



1x

T

3.

Montage-
anleitung

Istruzioni de
montage

Istruzioni per
il montaggio

Assembling
instruction

1 4x

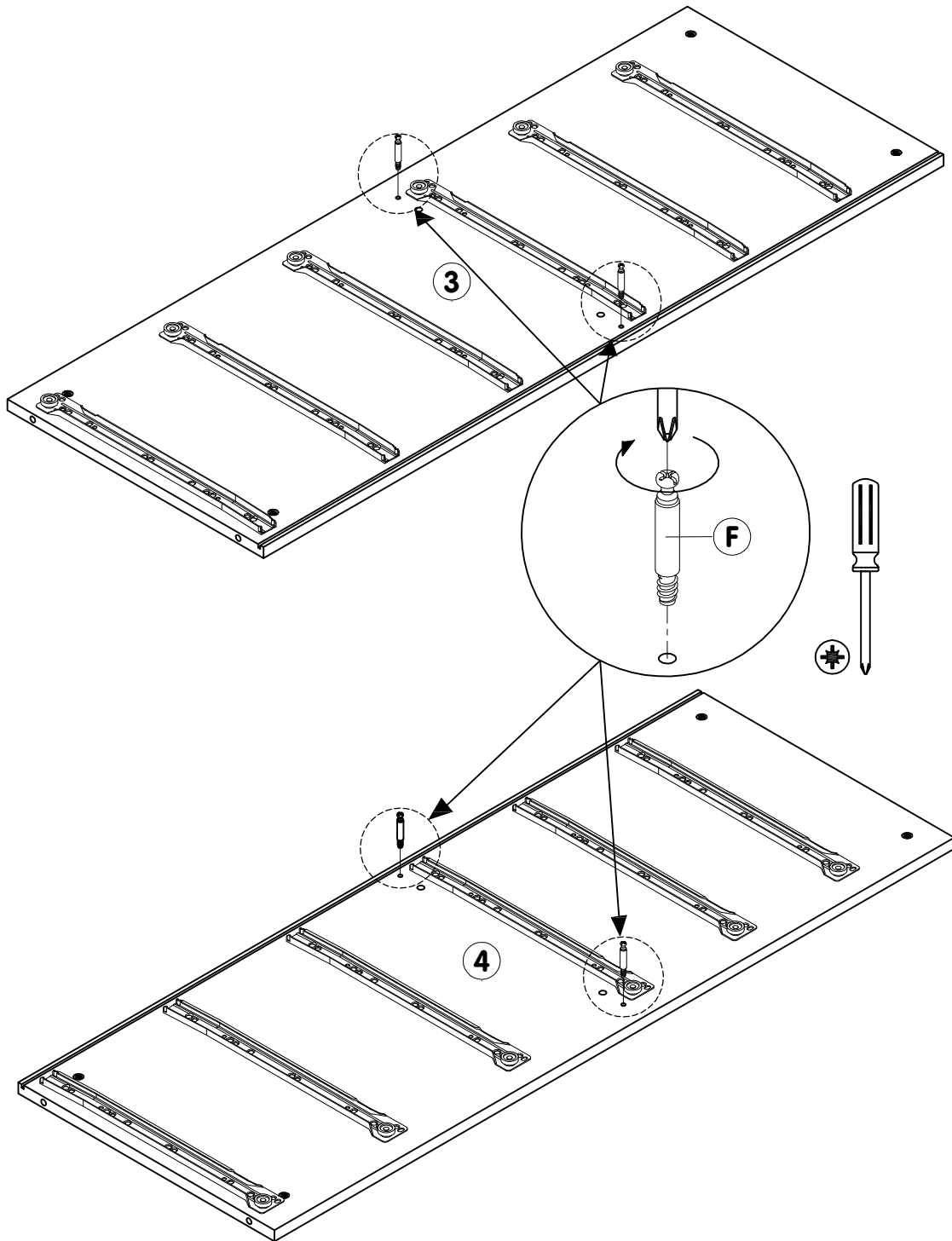

2 4x

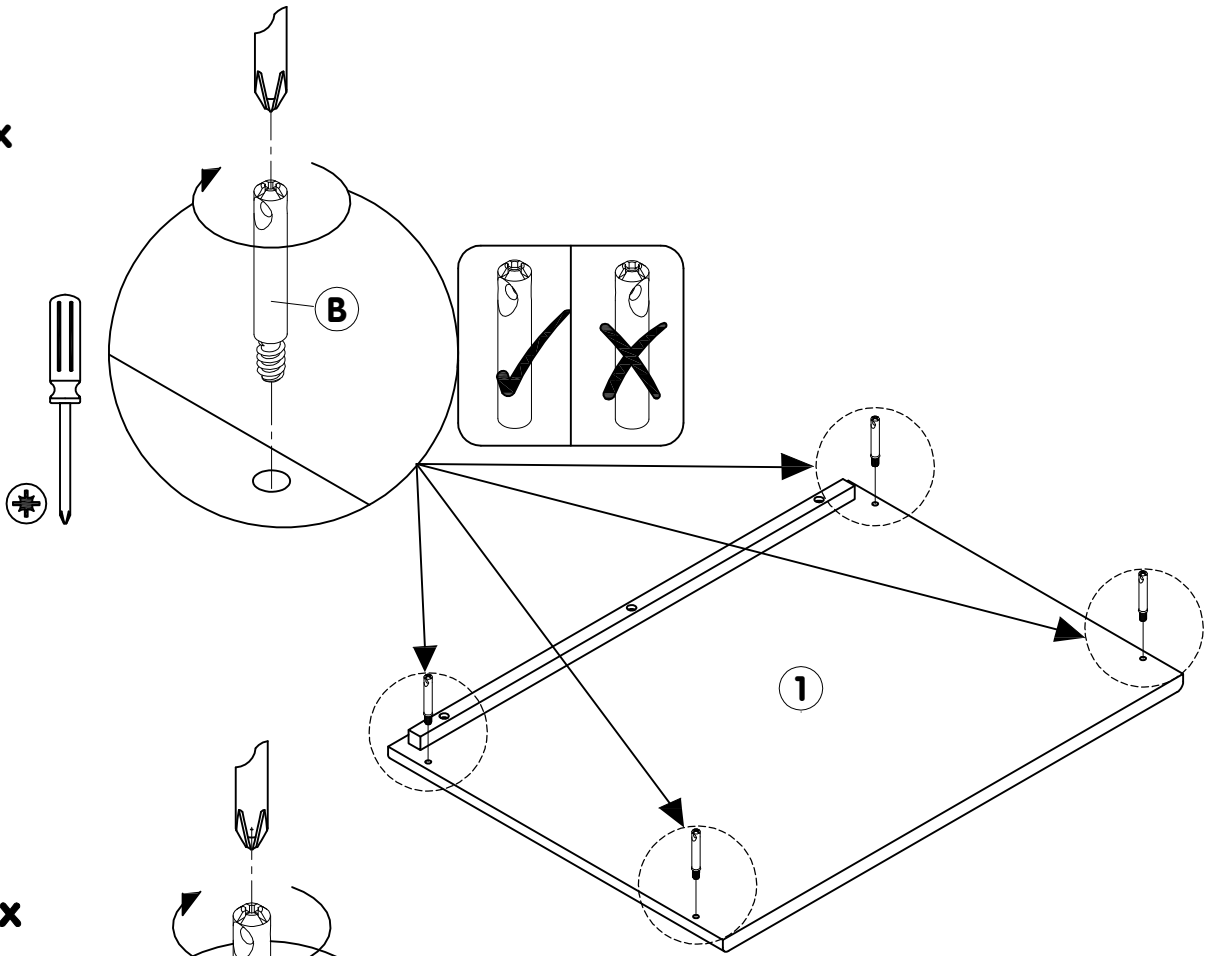

3 4x

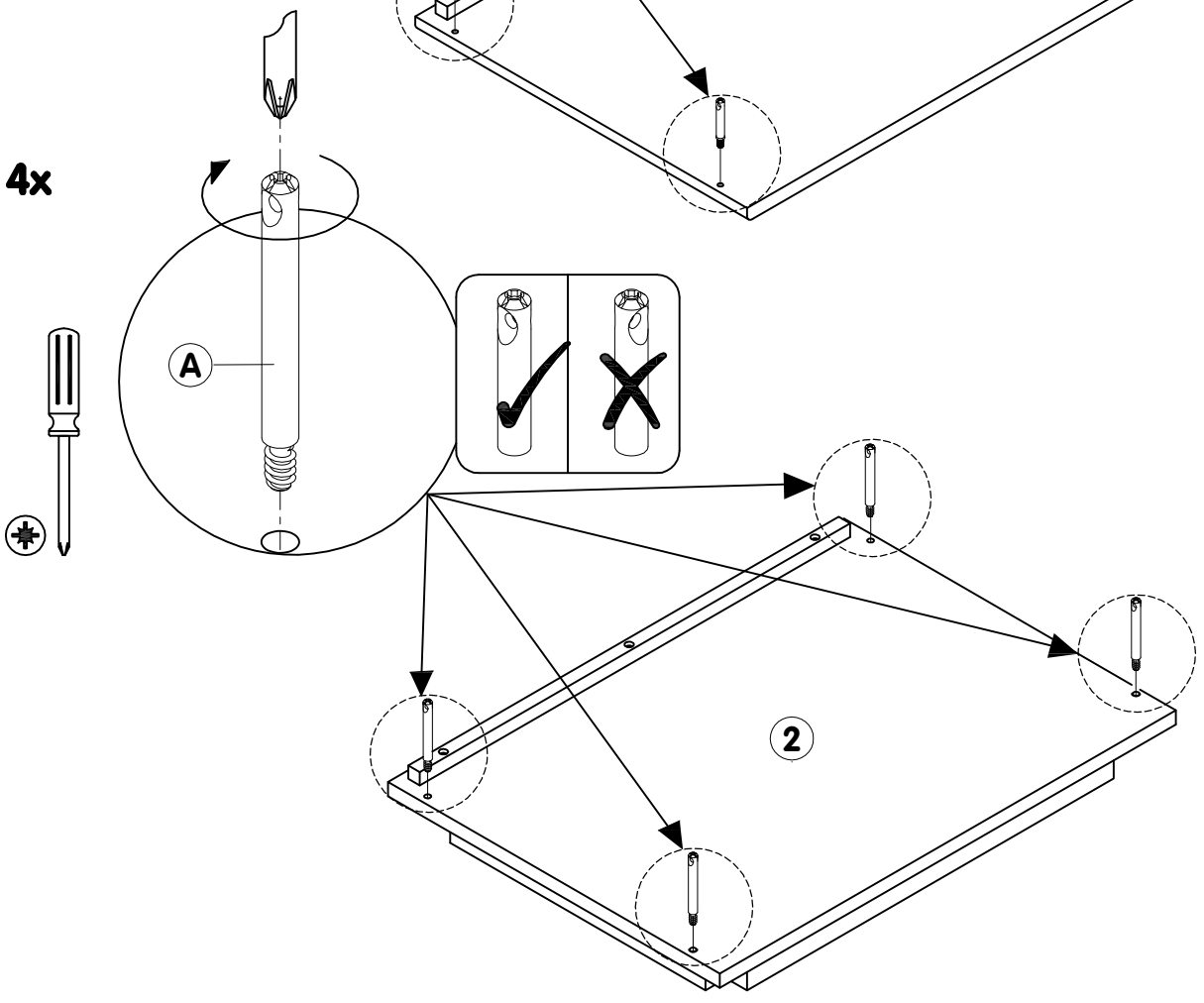

4 4x

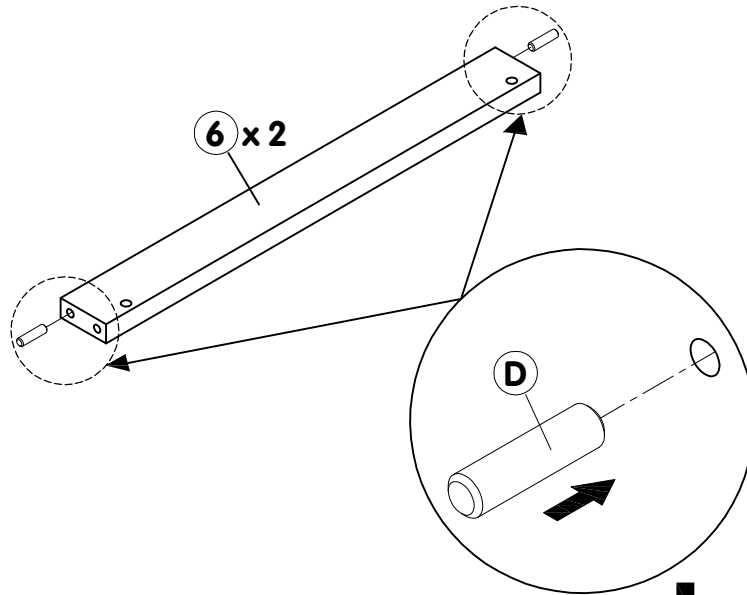

5 4x

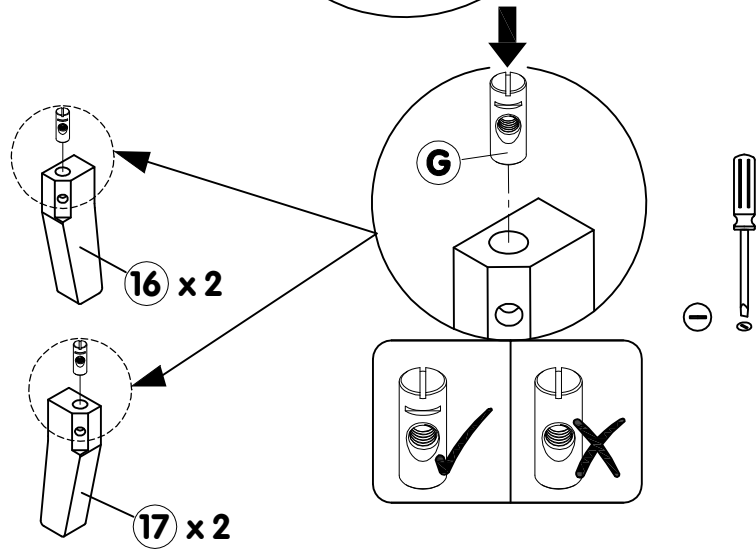

6 4x

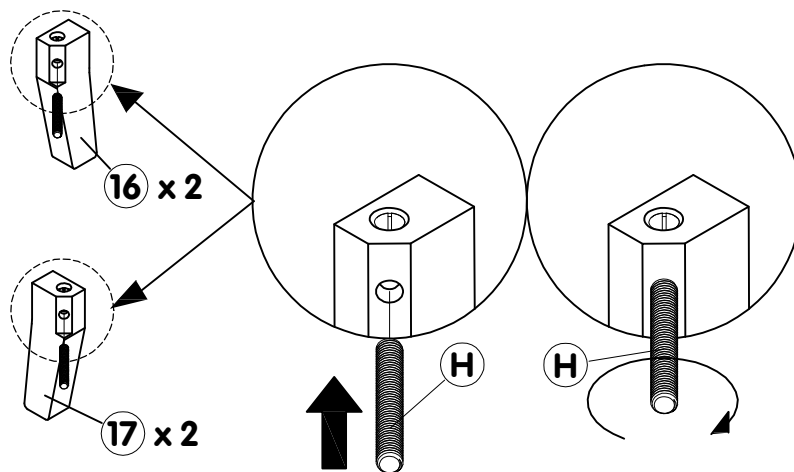

7 2x

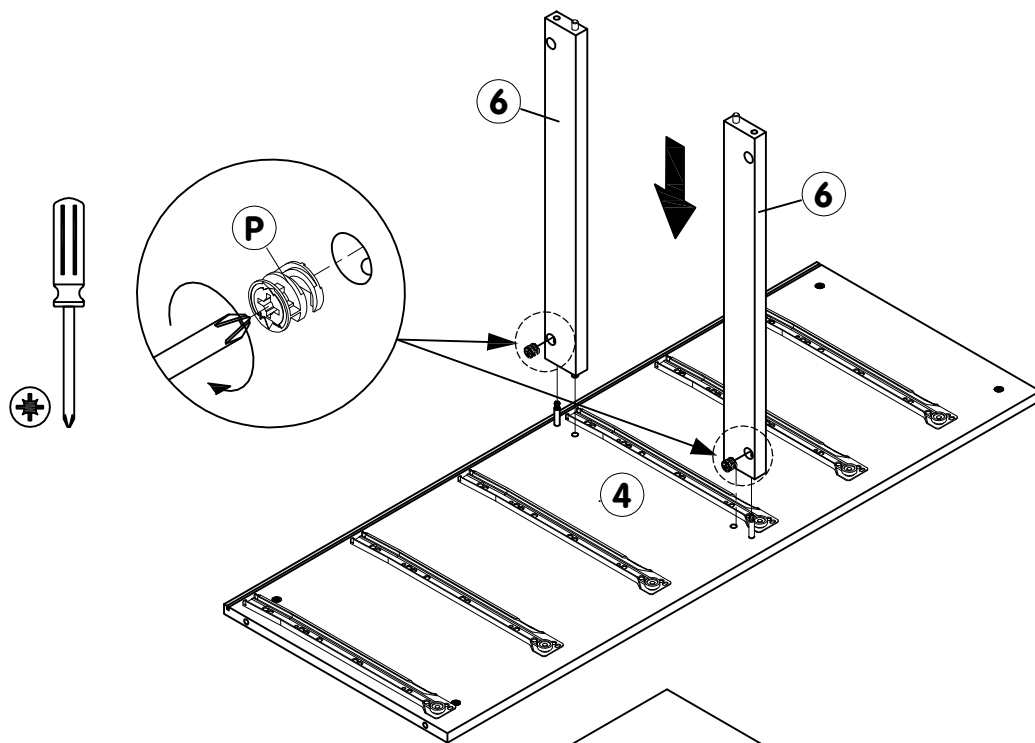

8 2x

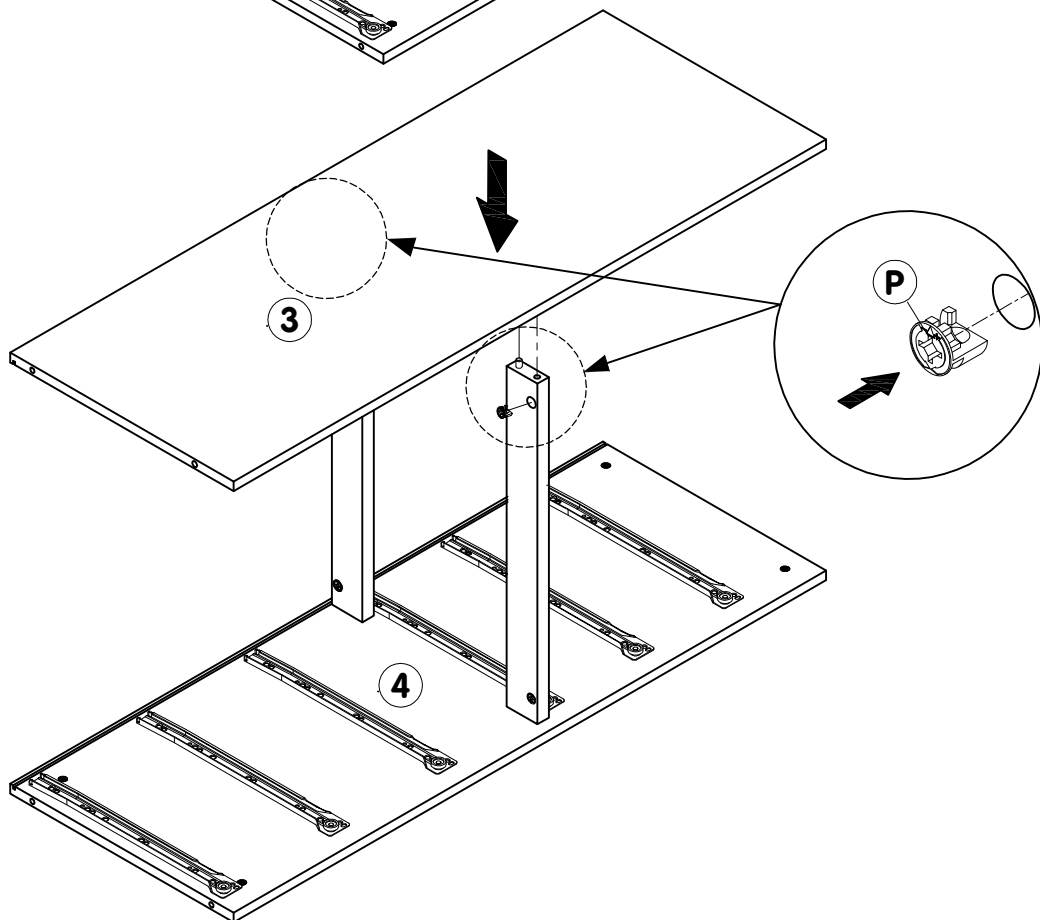

9 2x

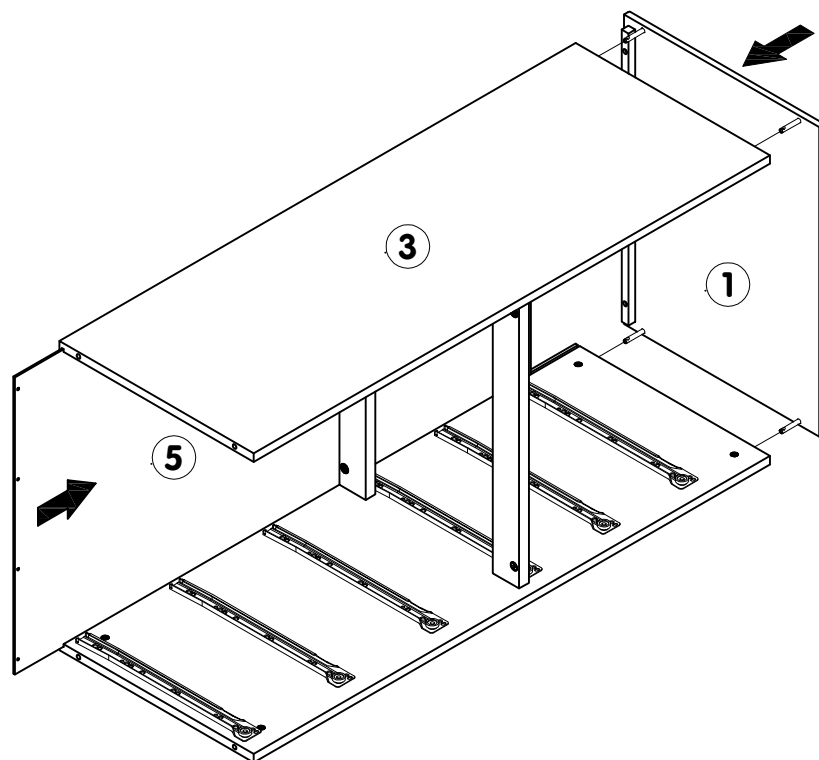

10 4x

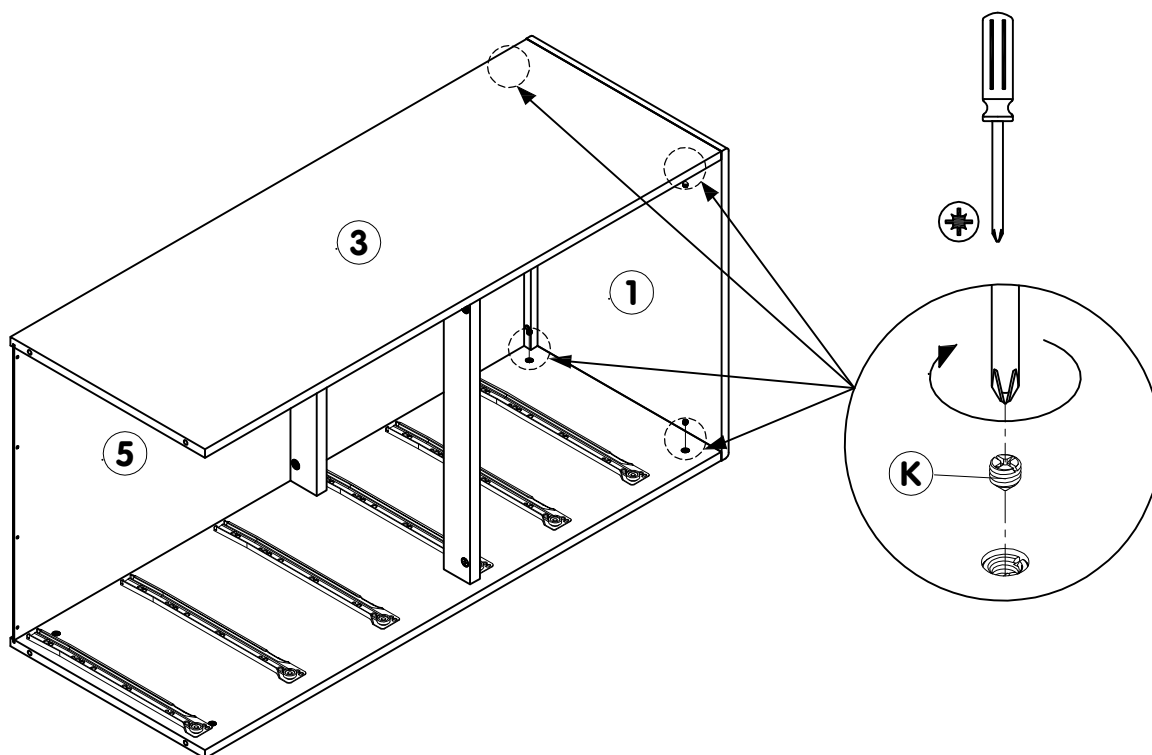

11 2x

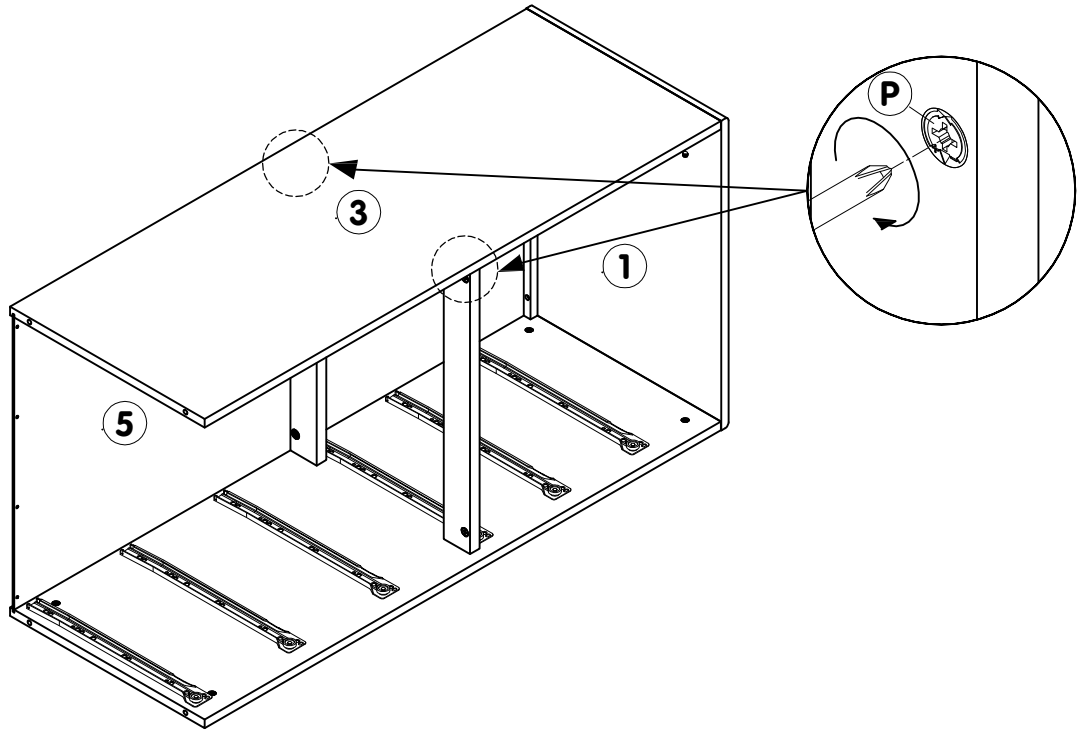

12 4x

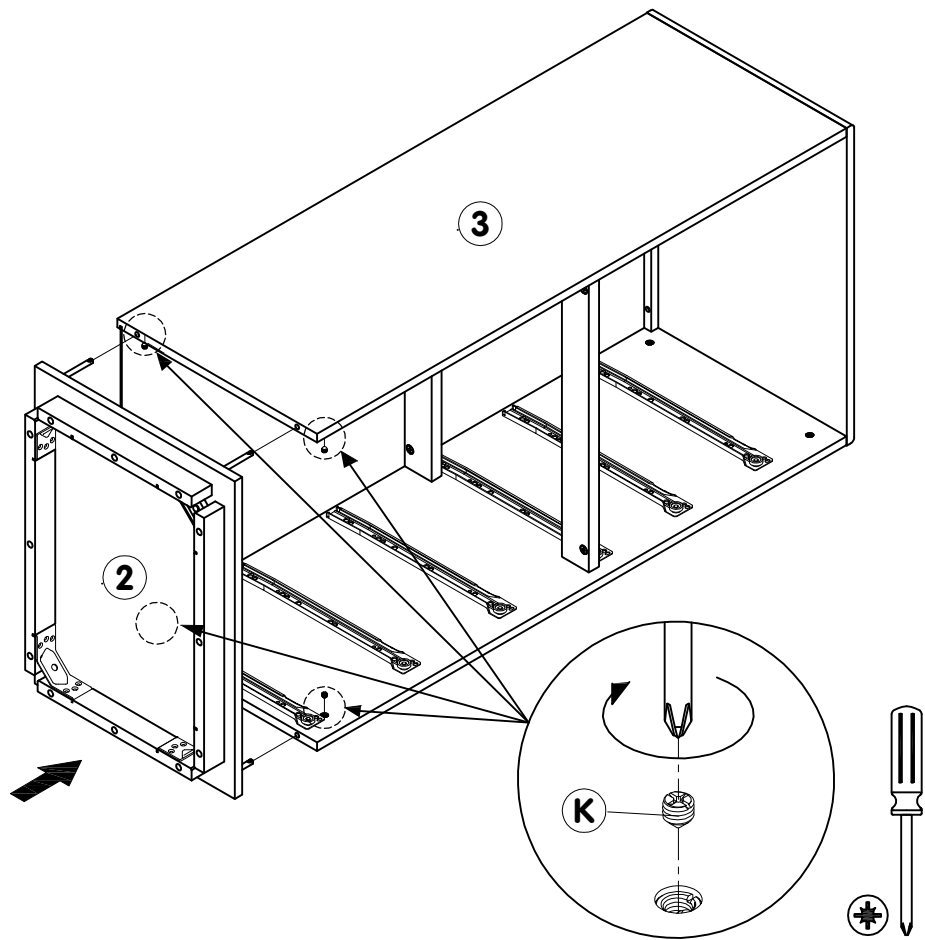

13 12x

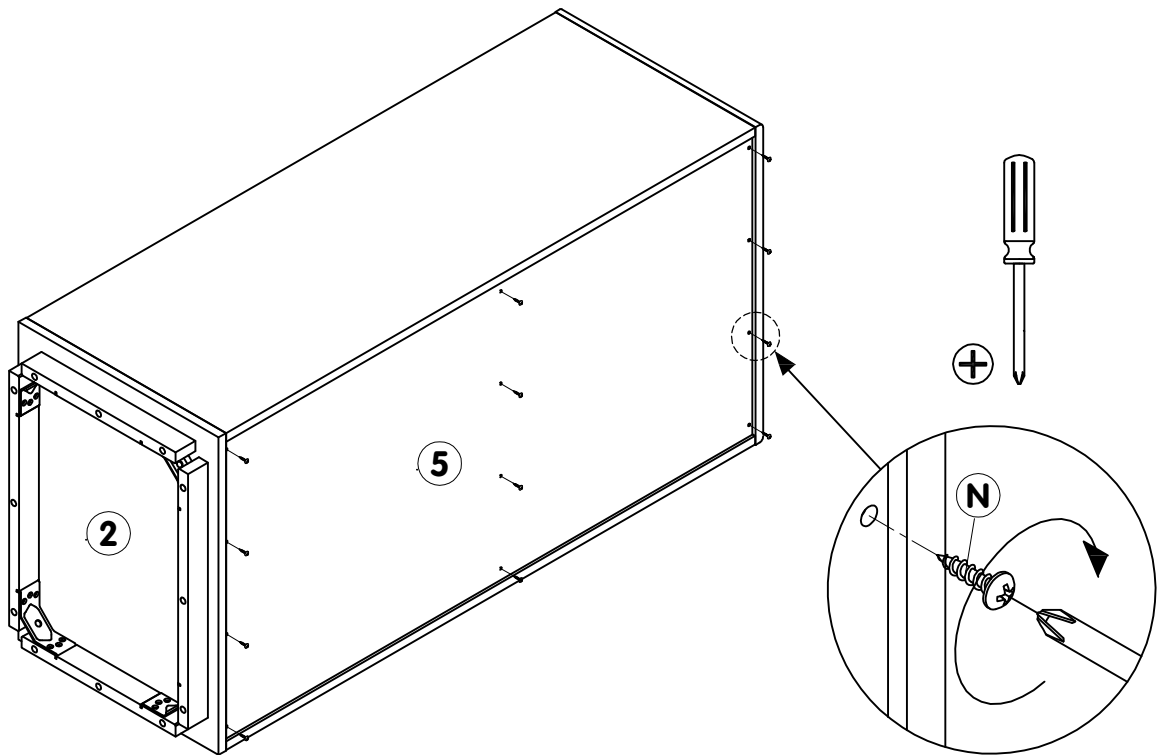

14 4x

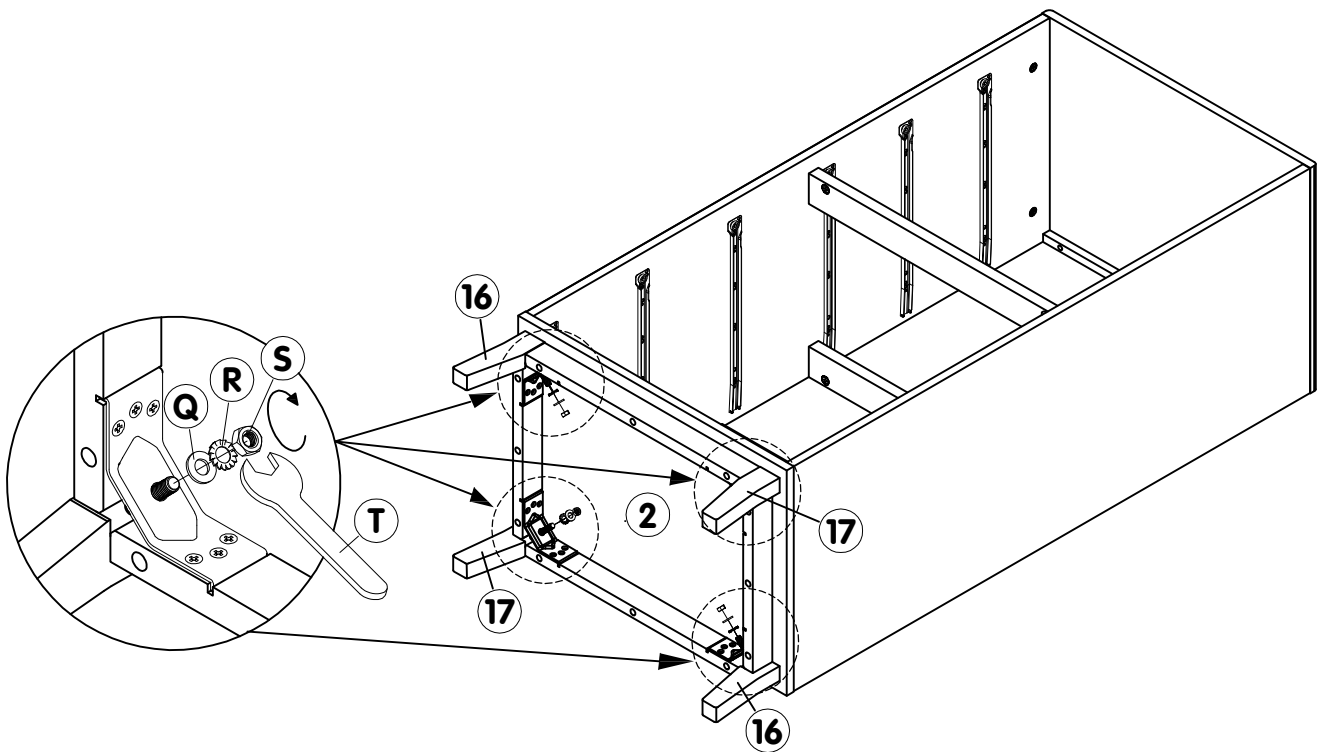

15 12x

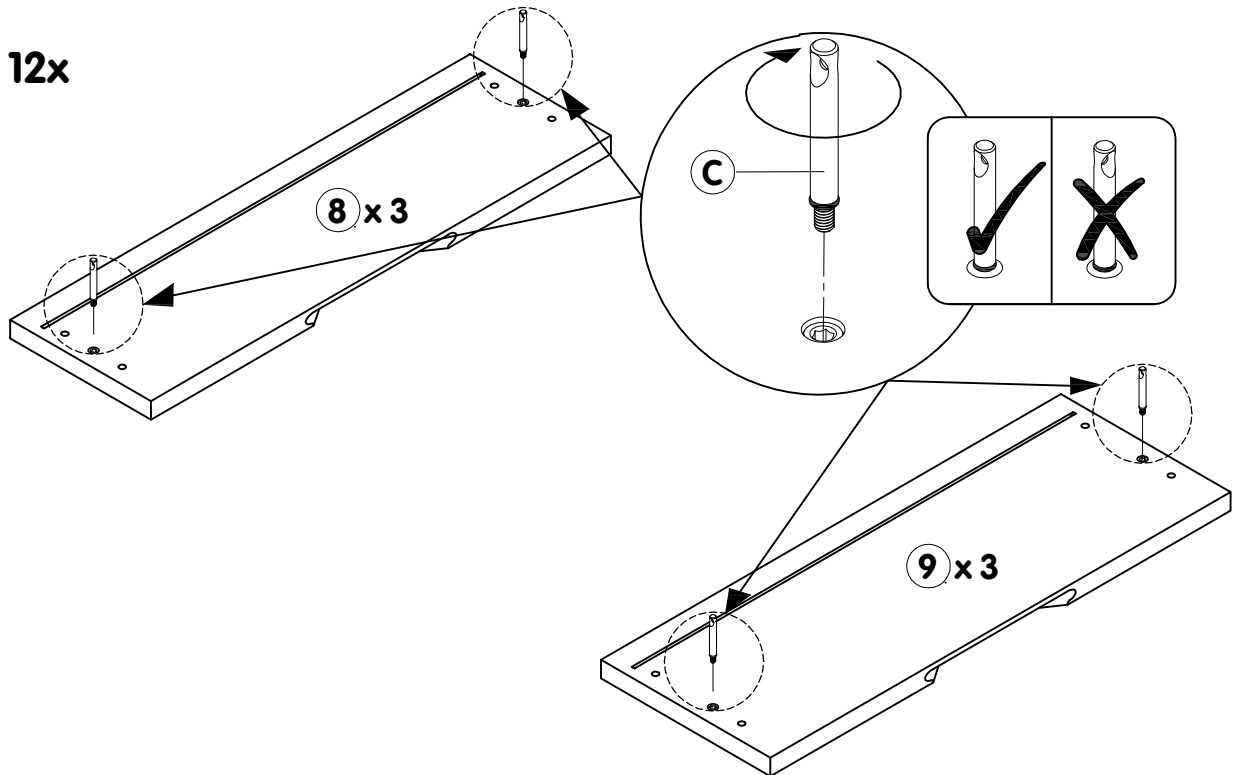

16 24x

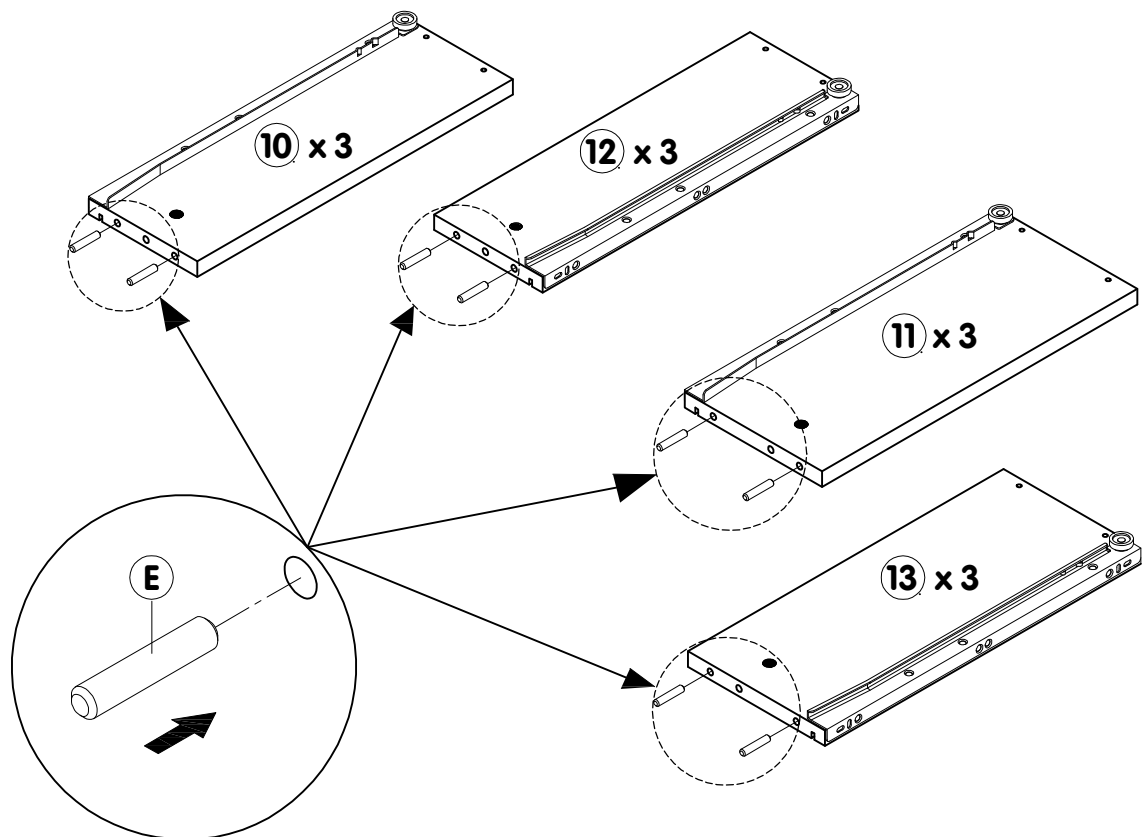

17 12x

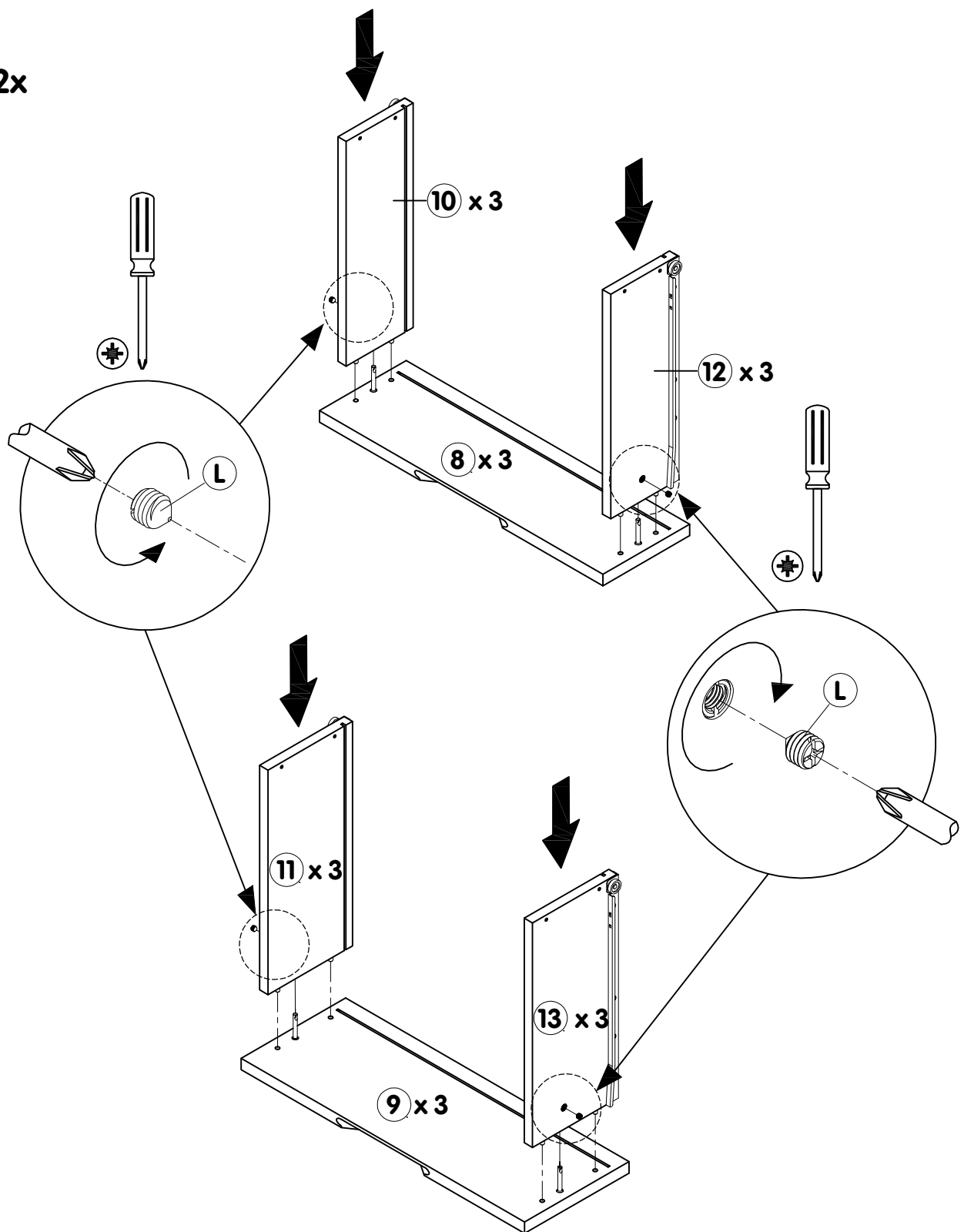

18 24x

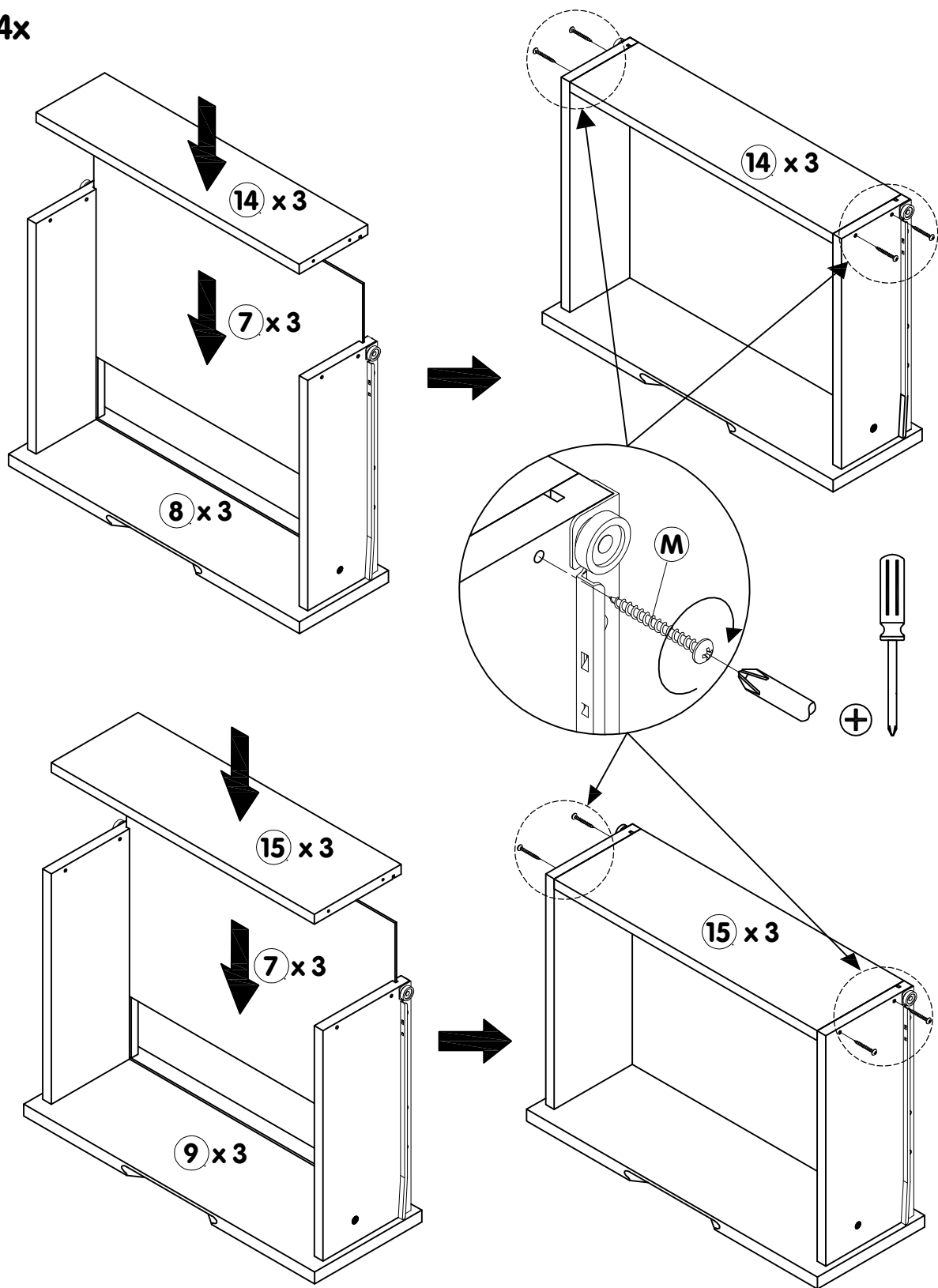

19 6x

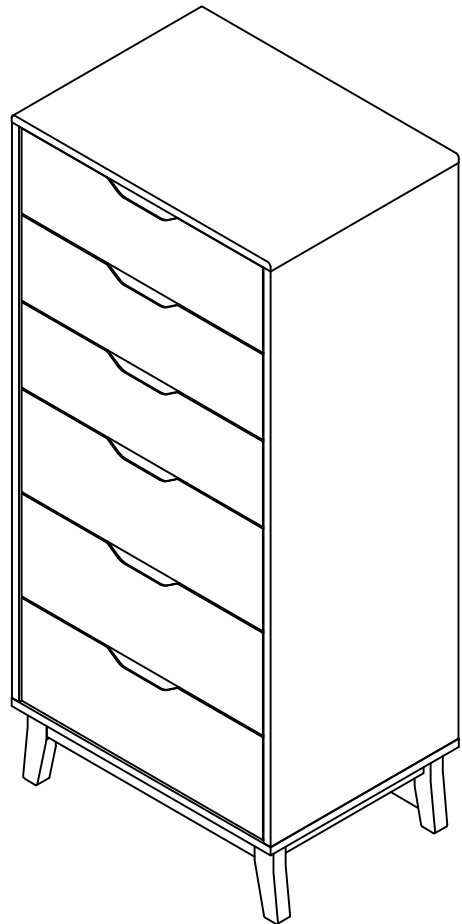
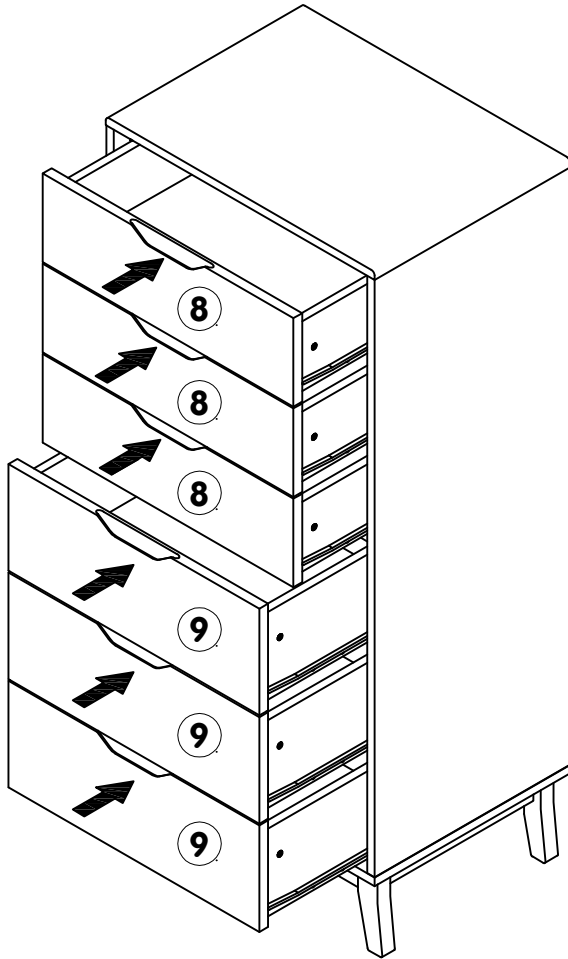

**Reinigung allgemein:**

Flecken immer sofort entfernen. Ein sauberes, weisses Tuch verwenden.

Nettoyage en général:

Toujours éliminer immédiatement les taches. Utiliser un chiffon blanc, propre.

Pulizia generale:

rimuovere sempre subito le macchie. Utilizzare un panno bianco, pulito.

General cleaning instructions:

Always remove stains immediately. Use a clean, white cloth.



Sauberes Wasser verwenden. Lässt sich der Fleck so nicht entfernen, seifenhaltiges Wasser verwenden. Werden Reinigungsmittel verwendet, diese immer zuerst an einer nicht sichtbaren stelle testen.

Utiliser une eau propre. Si la tache ne s'enlève pas, utiliser une eau savonneuse. Si un produit de nettoyage est utilisé, toujours l'essayer préalablement dans un endroit invisible.

Utilizzare acqua pulita. Se la macchia non viene via, utilizzare dell'acqua con sapone. Se si utilizzano dei detergenti, provarli sempre prima in un punto non visibile.

Use clean water. If the stain does not come out, use soapy water. If you use cleaning detergents, always test them first in a concealed spot.



ACHTUNG Keine chemischen, scheuern- oder kratzenden Reinigungs-/Hilfsmittel verwenden.

ATTENTION Ne pas utiliser de produits ou moyens chimiques, agressifs ou abrasifs.

ATTENZIONE Non utilizzare detergenti chimici o prodotti/materiali abrasivi.

CAUTION Do not use any chemical or abrasive cleaning detergents or cloths/tools.

**Möbelpflege:**

Lackiertes Holz nur mit einem leicht feuchten Tuch abwischen.

Entretien des meubles: Essuyer le bois vernis uniquement avec un chiffon légèrement humide.

Cura dei mobili: pulire il legno laccato Utilizzando soltanto un panno leggermente umido.

Furniture care:

Only wipe varnished wood with a slightly damp cloth.



Geölte Holzoberflächen je nach Gebrauch, von Zeit zu Zeit (z.B. halbjährlich) erneut ölen.

Pour les surfaces en bois huilé, appliquer de temps à autre (p.ex. tous les 6 mois) et en fonction de l'utilisation une huile pour bois.

Le superfici di legno oliate di tanto in tanto, a seconda del loro utilizzo (ad es. ogni sei mesi), devono essere nuovamente trattate con olio.

Re-oil oiled wooden surfaces from time to time (e.g. every half a year) depending on use.

4.

Pflege

Soin

Cura

Care

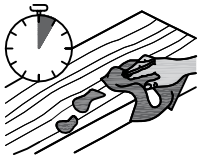

Feuchtigkeitsrückstände auf geölte und gewachsene Flächen müssen sofort entfernt werden. Ansonsten kommt es zu Fleckenbildung.

Les restes d'humidité sur les surfaces huilées et cirées doivent être immédiatement enlevés. Risque de formation de taches.

È necessario eliminare subito i residui di umidità dalle superfici oliate e cerate, altrimenti c'è il rischio che si formino delle macchie.

To prevent stains, immediately wipe off any wet spots on oiled and waxed surfaces.



ACHTUNG Keine chemischen, scheuern oder kratzenden Reinigungs-/Hilfsmittel verwenden

ATTENTION Ne pas utiliser de produits ou moyens chimiques, agressifs ou abrasifs.

ATTENZIONE Non utilizzare detergenti chimici o prodotti/materiali abrasivi.

CAUTION Do not use any chemical or abrasive cleaning detergents or cloths/tools.

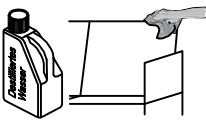
**Leder/Stoff:**

Flecken immer sofort mit destilliertem Wasser entfernen. Ein sauberes, weisses Tuch verwenden.

Cuir/tissu:

Toujours éliminer immédiatement les taches avec de l'eau distillée. Utiliser un chiffon blanc, propre.

Pelle/tessuto:

rimuovere sempre subito le macchie utilizzando acqua distillata. Utilizzare un panno bianco, pulito.

Leather/fabric:

Always remove stains immediately with distilled water. Use a clean, white cloth.

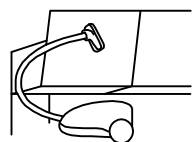

Oberflächen regelmäßig absaugen, damit durch Schmutz keine Abnutzungserscheinungen oder Schäden entstehen.

Aspirer régulièrement les surfaces afin d'éviter l'usure ou les dommages par la saleté.

Aspirare regolarmente in modo che lo sporco non logori o danneggi le superfici.

Vacuum surfaces on a regular basis so the dirt does not cause any signs of wear or damage.

5. Wartung Entretien Manutenzione Maintenance



Schrauben:

Für einwandfreie, zuverlässige Funktion, Schrauben regelmäsig nachziehen (z.B. halbjährlich).

Vis:

Resserrer régulièrement les vis (p.ex. tous les 6 mois) pour assurer un fonctionnement sûr et correct.

Viti:

per garantire un funzionamento corretto e sicuro tirare regolarmente le viti (ad es. ogni sei mesi).

Screws:

To keep your furniture in good working order, tighten the screws regularly (e.g. every six months).

6. Entsorgung Élimination Smaltimento Disposal



Entsorgungsservice:

Micasa bietet Ihnen einen Entsorgungsservice an. Weitere Informationen erhalten Sie unter www.micasa.ch

Entsorgung:
Nicht mehr verwendete Möbel der fachgerechten Entsorgung übergeben. Wenden Sie sich an Ihre lokale Entsorgungsstelle.

Service d'élimination:

Micasa vous propose un service d'élimination. Vous trouverez des informations supplémentaires sur www.micasa.ch

Élimination:
Veuillez remettre les meubles qui ne sont plus utilisés à une entreprise d'élimination. Adressez-vous à votre centre de collecte local.

Servizio di smaltimento:

Micasa vi offre un servizio di smaltimento. Ulteriori informazioni sono disponibili su www.micasa.ch

Smaltimento:
i mobili dismessi devono essere conferiti presso i centri di raccolta rifiuti per il loro corretto smaltimento. Rivolgersi presso il centro di raccolta locale.

Disposal service:

Micasa offers a disposal service. For more information visit www.micasa.ch

Disposal:
To correctly dispose of furniture that is no longer used, contact your local recycling centre.

7.

**Kontakt /
service**

**Contact /
service**

**Contatto /
servizio**

**Contact /
service**



Fragen /
Anregungen:
Wir sind gerne für Sie
erreichbar:
Montag bis Freitag
08.00 bis 18.00 Uhr
Samstag
08.30 bis 16.30 Uhr
Tel. 0800 840 848

Questions /
suggestions:
Nous sommes à votre
disposition:
Lundi - vendredi
08h00 à 18h00
Samedi
08h30 à 16h30
Tél. 0800 840 848

Domande /
suggerimenti:
siamo a vostra
disposizione:
lunedì - venerdì
dalle 08.00 alle 18.00
sabato
dalle 08.30 alle 16.30
Tel. 0800 840 848

Questions /
Suggestions
Please contact us. Our
opening times are:
Monday - Friday
8.00 to 18.00
Saturday
8.30 to 16.30
Phone 0800 840 848



Ersatzteile:
Erhalten Sie direkt im
Online-shop von
Migros-Service:
www.migros-service.ch

Pièces de rechange:
Vous les obtenez
directement dans le
magasin en ligne de
Migros-Service:
www.migros-service.ch

Pezzi di ricambio:
sono disponibili diret-
tamente
sull'online-shop di
Migros-Service:
www.migros-service.ch

Spare parts:
Available directly from
the Migros-Service
online shop:
www.migros-service.ch