

FLEXA®

82-10016-1/-2/-15/
16/-25/-26

54/59 x 54 x 27cm

Flexa Bank
weiss/blau:
4048.569
natur:
4049.066
natur/rosa:
4049.067
natur/blau:
4049.068
weiss:
4049.069
weiss/rosa:
4049.070

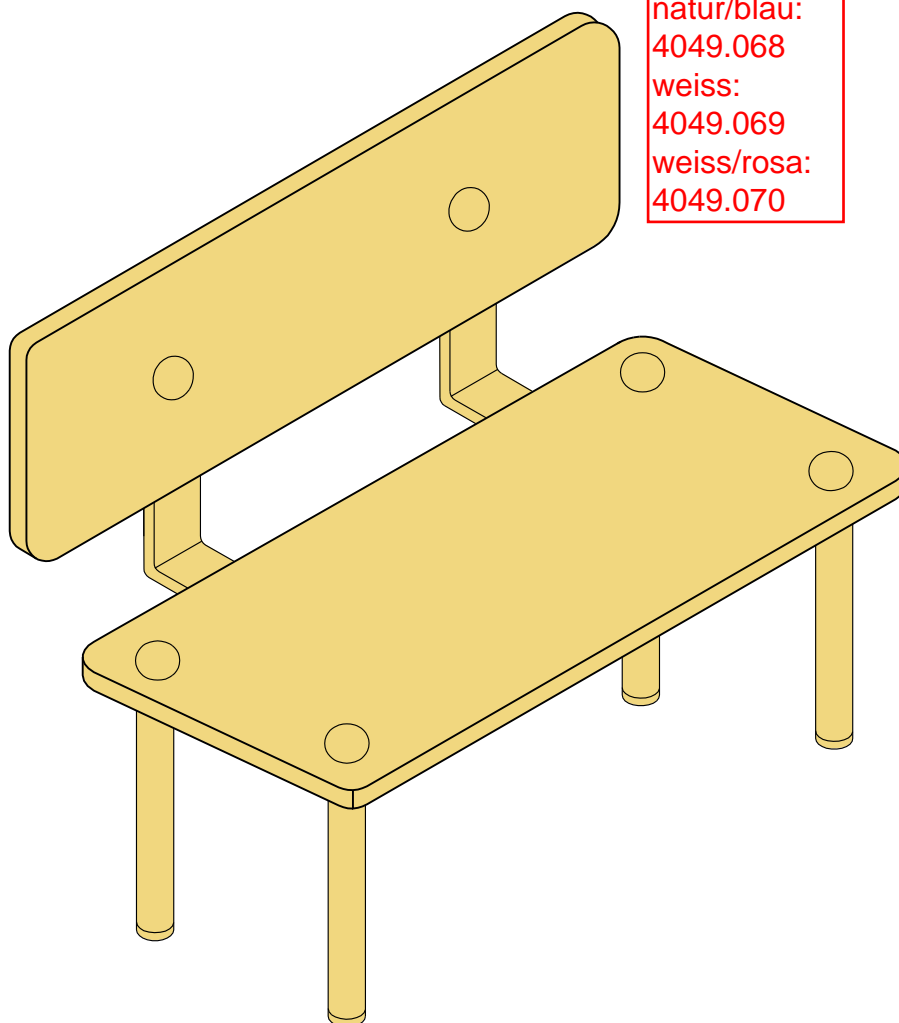

Monterings- og brugsvejledning

**Assembly instructions and
directions for use**

**Montageanleitung und
Gebrauchsanweisung**

**Notice de montage et mode
d'emploi**

Instrucciones de montaje y uso

**Montageinstructie en onderhouds-
voorschrift**

Istruzioni di montaggio e uso

For indoor
domestic use



Danish Design made in Denmark

9/April 2008
44-00656



Møbler fra FLEXA er fremstillet af massivt træ, hvilket betyder at farve- og strukturforskelle er en naturlig del af møblet.

Skulle der mod forventning opstå en reklamation, skal denne blanket udfyldes og returneres til FLEXA forhandleren.



Furniture from FLEXA is produced from solid wood, which means

that colour and structure difference are a natural part of the furniture. However should a complaint occur, this form must be filled and returned to your FLEXA stockist.



Die FLEXA Produkte werden aus massivem Kiefernholz hergestellt. Farbunterschiede

sowie unterschiedliche Maserungen sind Naturmerkmale. Sollte es trotzdem Grund zur Reklamation geben, füllen Sie bitte diesen Schein aus und wenden Sie sich an Ihren FLEXA Händler.

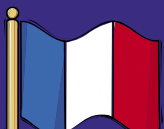

Les meubles FLEXA sont réalisés en pin massif. Certaines différences de teintes ou de structures

peuvent apparaître : elles proviennent de la matière naturelle du bois. Si toutefois vous constatiez une anomalie, merci de remplir la fiche ci-jointe et de la retourner à votre revendeur.



Los muebles de FLEXA están hechos de pino macizo, por lo cual pueden aparecer pequeñas diferencias en

el tono y la estructura del mueble, formado de manera natural. Si en contra de lo previsto surge una incidencia, hay que rellenar este formulario y devolverlo al distribuidor.



De meubelen van FLEXA zijn gemaakt van massief hout hetgeen betekent dat kleur en structuurverschillen een

natuurlijk onderdeel zijn van de meubelen. Mocht er desondanks een klacht ontstaan, vul dan dit formulier in en lever het in bij uw FLEXA dealer.

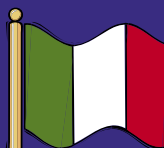

I mobili della FLEXA sono prodotto in legno di pino massiccio, significa che si possano verificarsi piccole

superficie che fanno parte delle caratteristiche del legno naturale. Comunque per qualsiasi reclamo bisogna riempire il modulo e consegnarlo al Vostro rivenditore.

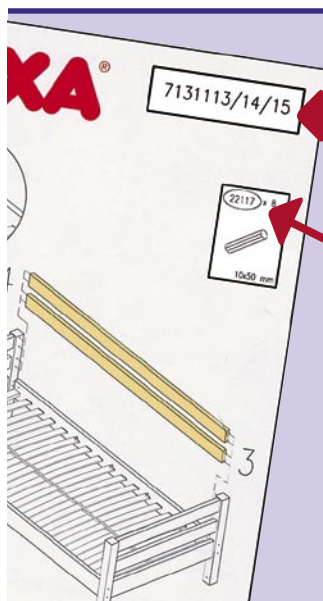

**Model nr. / Model No / Modell Nr. /
Modèle no / No Modelo / Artikel nr. /
Numero Modello**

**Emne nr. / Part / Teile-Nr. /
Pièce réclamée / No. pieza /
Onderdeelnummer / No. pezzo**

Årsag

1

Manglende del / Missing part/
Fehlendes Teil / Pièce manquante /
Falta pieza / Missende delen / Parte
mancante

Reason

Ursache

2

Fejl i træet / Defect in the wood /
Holzfehler / Défaut de bois /
Madera defectuosa / Fout in het
hout / Difetto nel legno

Motif

Motivo

3

Oorzaak





Motivo



Fejlboring / Faulty drilling
Falsche Bohrung / Défaut de
perçage
Taladro erróneo / Verkeerd geboord
Difetto forature

4

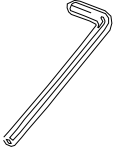
Fejl i lakken / Fault in lacquer
Fehler im Lack / Défaut de finition
Barniz defecto / Fout in de
lakafwerking / Difetto laccatura

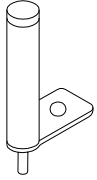
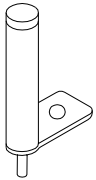
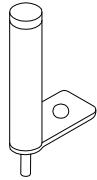
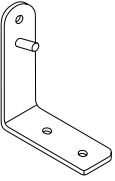
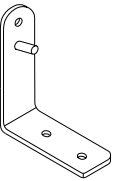
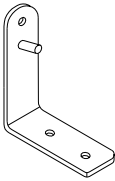

<p>22035 x 4</p>  <p>ø9 x 22/M6 x19mm</p>	<p>22600 x 2</p>  <p>ø9 x 15/M6 x12mm</p>	<p>22125 x 4</p>  <p>4,5x25 mm PH</p>	<p>22003 x 1</p>  <p>4 mm</p>	<p>22680 x 4</p>  <p>3x12 mm PH</p>
--	--	--	--	---

<p>82-10016-1/-2</p> <p>4092-036-2 x 6</p>  <p>ø32/M6 x 13mm</p>	<p>82-10016-15/-25</p> <p>22379 x 6</p>  <p>ø32/M6 x 13mm</p>	<p>82-10016-16/-25</p> <p>22380 x 6</p>  <p>ø32/M6 x 13mm</p>
<p>4081-032-2 x 4</p> 	<p>4081-032-5 x 4</p> 	<p>4081-032-6 x 4</p> 
<p>4092-037-2 x 2</p>  <p>150x210 mm</p>	<p>22381 x 2</p>  <p>150x210 mm</p>	<p>22382 x 2</p>  <p>150x210 mm</p>

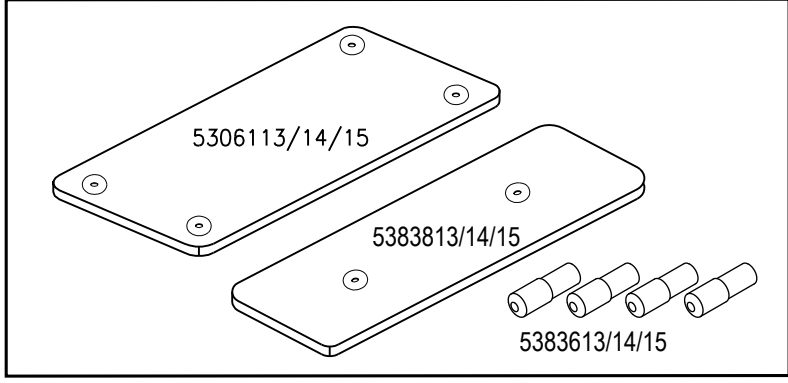
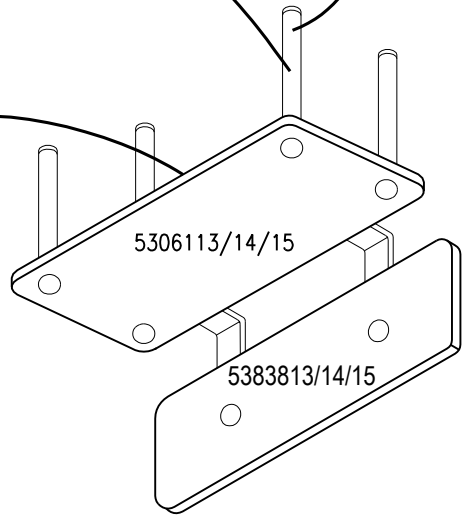
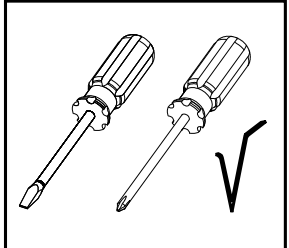
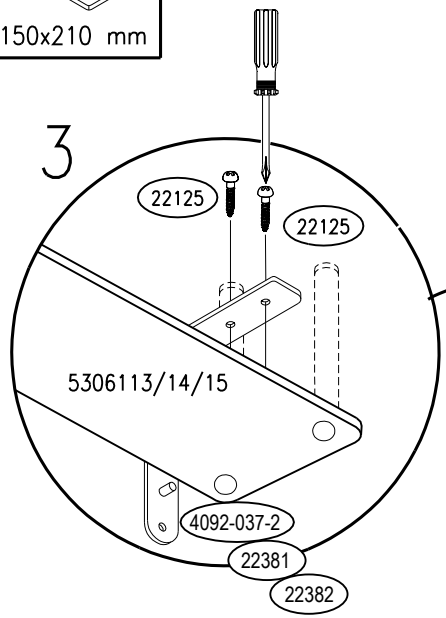
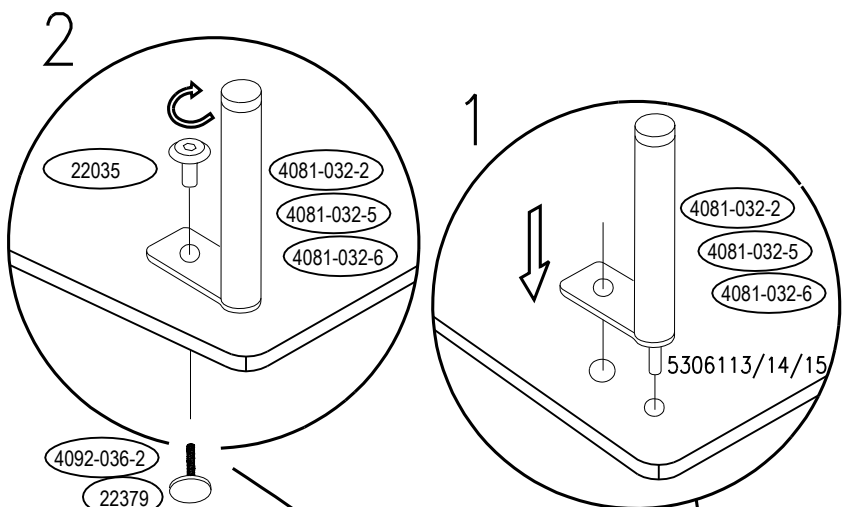

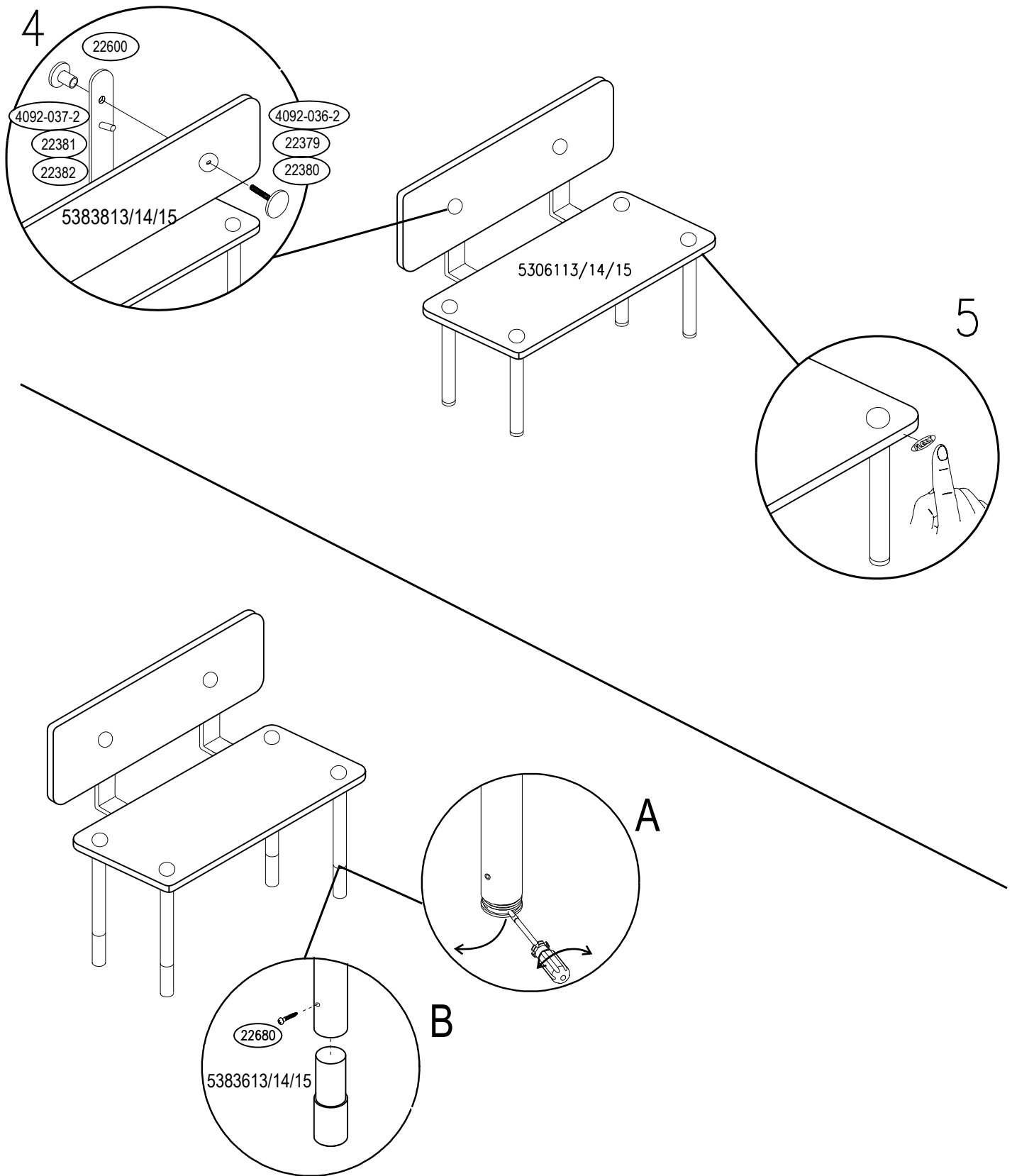

<p>(DK) RÅD OM VEDLIGEHOLDELSE: Tør af med en fugtig klud. Evt. større pletter fjernes med en fugtig svamp med sæbe. Undgå opløsningsmidler. Skruer og bolte efterspændes med jævne mellemrum.</p>	<p>(GB) MAINTENANCE INSTRUCTIONS: Cleaning with a wet cloth, use a sponge with soap to remove obstinate dirt. Avoid solvents and dilutions. Screws and bolts should from time to time be retightened.</p>	<p>(D) PFLEGEHINWEIS: Pflege mit einem feuchten Lappen. Für hartnäckigen Schmutz empfehlen wir einen Schwamm mit Seife. Vermeiden Sie Lösungs- und Verdünnungsmittel. Schrauben und Bolzen sollten regelmäßig nachgezogen werden.</p>	<p>(F) CONSEILS D'ENTRETIEN: Entretien avec un chiffon humide pour la poussière - les taches rebelles s'enlèvent avec une éponge légère - ment savonneuse. Éviter tous solvants et diluants. Votre lit doit être vérifié périodiquement afin de resserrer les vis.</p>	<p>(E) CONSEJO PARA LA CONSERVACIÓN: Limpiar con un paño húmedo. Para quitar manchas mas grandes usar una esponja con jabón. Evitar usar productos quimicos. Las herrajes necesitan opretarse a veces.</p>	<p>(NL) ONDERHOUD: Reinigen met een vochtige doek. Hardnekkig vuil verwijderen met een spons en zeep. Vermijd oplos- en verdunningsmiddelen. Schroeven en moeren regelmatig aandraaien.</p>	<p>(I) CONSIGLI PER LA MANUTENZIONE: Pulire con un panno umido, usare una spugna impregnata di sapone per togliere lo sporco persistente. Evitare l'uso di prodotti chimici. Dadi e viti sono, di tanto e tanto, da ri-avvitare.</p>
---	--	--	---	---	--	---