Wichtig:

VOR GEBRAUCH SORGFÄLTIG DURCHLESEN/
MONTAGEANLEITUNG FÜR
SPÄTERS NACHLESEN
AUFBEWAHREN

Important:

LISEZ ATTENTIVEMENT/
CONSERVER LES INSTRUCTIONS
D'INSTALLATION
POUR RÉFÉRENCE FUTURE
AVANT UTILISATION

Importante:

LETTURA/CONSERVARE
ISTRUZIONI PER L'INSTALLAZIONE
PER RIFERIMENTO
FUTURO ACCURATAMENTE
PRIMA DELL'USO

Important:

READ CAREFULLY BEFORE
ASSEMBLING/KEEP AND
STORE INSTRUCTION FOR
REFERENCE

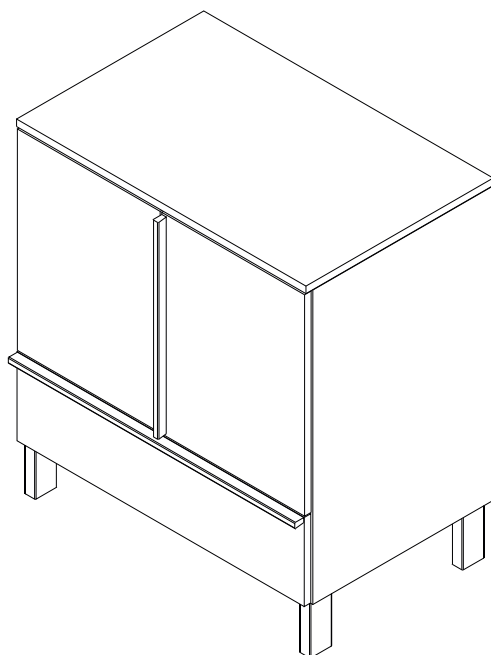
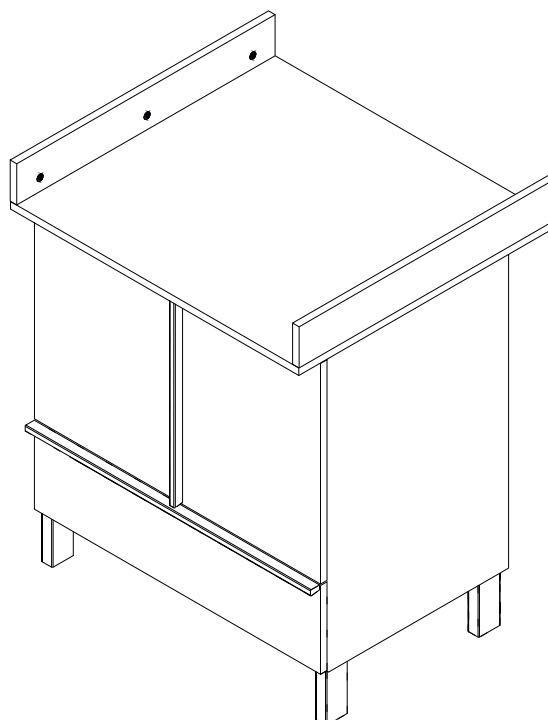
A**Kommode****B****Wickel-Aufsatz**

Für Kinder bis 15 kg! • For children weighing less than 15 kg (33 lbs)! • Pour les enfants pesant moins de 15 kg ! • Per bambini di max. 15 kg !

Artikelnummer BQ-301.03WSF1 + BQ-301.03WSF2

**BUITIQ GmbH
CH-6030 Ebikon**

www.buitiq.ch

Sicherheitshinweise

Nur im kompletten Aufbau als Wickelkommode zu verwenden!

- Bitte überzeugen Sie sich regelmäßig vom festen Sitz aller Schrauben. Schrauben dürfen nicht lose sein, weil sich ein Kind Körperteile quetschen kann oder Kleidung (z.B. Schnüre, Halsketten, Bänder, Puppen usw.) sich verfangen kann. Es könnte die Gefahr der Erdrückung bestehen.
- Bitte stellen Sie die Wickelkommode so auf, dass das Wickelbrett direkt an die Wand anstößt. Durch eine feste Verbindung von Wickelbrett und Wand kann jegliches Kippen verhindert werden. Verwenden Sie für an die Wand anzubringende Wickeleinrichtungen nur angemessene Schrauben und Dübel. Prüfen Sie die Wand, ob der Dübel dafür geeignet ist.
- Denken Sie an das Risiko von offenem Feuer und anderen starken Hitzequellen, wie elektrische Heizstrahler, gasbeheizte Öfen usw. in der unmittelbaren Umgebung der Wickeleinrichtung.
- Die Wickelkommode ist nicht zu benutzen, wenn irgendein Teil defekt ist, abgerissen ist oder fehlt. Kunststoffbeutel und etwaige Kunststoffelemente/Verpackungen sind sofort zu entfernen oder für Kinder unzugänglich aufzubewahren!
- Heben Sie die Aufbauanleitung und den Inbusschlüssel für eine spätere Demontage bzw. Montage gut auf. Bitte benutzen Sie für die Montage den beiliegenden Inbusschlüssel und einen Schraubenzieher. Um Beschädigungen am Produkt zu vermeiden, darf zum Anschrauben der Beschläge kein Akkuschrauber verwendet werden.
- Sollte Ihre Wickelkommode mit Rollen ausgestattet sein, sind diese vor dem Gebrauch fest zu stellen.

Beachten Sie bitte:

Nur original Zubehör- und Ersatzteile vom Hersteller oder Lieferanten verwenden. Die Wickelaufgabe muss an die Wand befestigt werden.

Safety requirements

Only use as changing unit if completely assembled!

- Please check regularly that the screws are well tightened. The screws should not be loose, as children could squeeze certain parts of their body or catch items of clothing (e.g. laces, necklaces, bands, dolls etc.). These might present the hazard of strangulation.
- Please set up the changing unit so that the changing board is leaning directly against the wall. Tilting can be prevented by tightly anchoring the changing board in the wall. Use only appropriate screws and wall plugs for changing units that are meant to be fixed to the wall. Check the wall to determine whether the wall plug is suitable for it.
- Take into consideration the risks of open fires and other strong heat sources like electric heaters, gas stoves etc. in the close proximity of the changing unit.
- Do not use the changing unit if single parts are broken, torn or missing. Synthetic bags or other synthetic elements/wrappings should be immediately removed or kept out of the reach of children.
- Keep the assembly plan and the hex key for future disassembly or assembly. Please use only the enclosed hex key and a screwdriver for the assembly. To avoid damaging the product, do not use an electric screwdriver for tightening the screws!
- Should your changing unit be featured with castors, they have to be locked before using.

Please note:

Use only original accessories and spare parts from the producer or from the providers. The changing mat must be mounted on the wall.

Consignes de sécurité

Utiliser comme une commode à langer seulement si elle est complètement assemblée!

- Veuillez vous assurer régulièrement que toutes les vis sont bien serrées. Les vis ne doivent pas être desserrées, parce qu'un enfant peut se coincer ou des vêtements (p. ex. lacets, colliers, bandes, poupées etc.) peuvent s'empêtrer. Il peut exister le risque d'étranglement. Veuillez installer la table à langer de manière à ce que le plateau de la table à langer soit en contact direct avec le mur.
- Une liaison fixe entre le plateau de la table à langer et le mur permet d'éviter tout basculement. Vérifier si le goujon est approprié pour le mur.
- Pensez aux risques liés aux feux ouverts ou à d'autres sources de fortes chaleurs, comme les radiateurs électriques, les chauffages à gaz etc. à proximité immédiate de la commode à langer.
- Ne pas utiliser la commode si l'une de ses parties est cassée, endommagée ou manquante. Enlever le papier et le plastique d'emballage et mettez-les immédiatement hors de la portée des enfants!
- Veuillez conserver soigneusement le manuel de montage et la clé à six pans pour un montage ou un démontage ultérieur.
- Utiliser pour le montage la clé à six pans ci-inclus et un tournevis. Pour ne pas détériorer le produit, vous ne devez pas utiliser un tournevis électrique pour fixer les vis!
- Ne pas utiliser la commode si l'une de ces parties est cassée, endommagée ou manquante. Si votre commode à langer est prévue avec des roues, celles-ci doivent être bloquées avant l'usage de la commode.

Veillez noter:

N'utilisez que des accessoires et des pièces de rechange d'origine du fabricant ou du fournisseur. Le matelas à langer doit être fixé au mur.

Requisiti di sicurezza

Il fasciatoio sarà utilizzato come tale, solo se è assemblato per intero!

- Assicurarsi regolarmente che tutte le viti siano ben serrate. Esse non devono essere lente in quanto il bambino potrebbe schiacciarsi parti del corpo o gli indumenti si potrebbero impigliare (es. Cordini, catenine, nastri, bambole ecc.). potrebbe esserci pericolo di strangolamento. Collocare il prodotto in modo che il fasciatoio appoggi direttamente alla parete. Ancorando il fasciatoio nella parete si può evitare il rischio di ribaltamento. Per l'ancoraggio nella parete utilizzare soltanto viti e tasselli adatti. Verificare la parete per assicurarsi che il tassello sia adatto.
- Prendere in considerazione il rischio di una fonte di fuoco aperto o altre fonti di calore intenso, come riscaldatori elettrici, stufe a gas ecc. nelle vicinanze del prodotto.
- Non utilizzare più il prodotto se alcuni pezzi sono danneggiati, rotti o mancano del tutto. I sacchetti in plastica o altri elementi in plastica / confezioni devono essere rimossi immediatamente e tenuti fuori dalla portata dei bambini!
- Conservare con cura le istruzioni di assemblaggio e la chiave a brugola per un eventuale smontaggio, ossia futuro assemblaggio.
- Per l'assemblaggio si prega di utilizzare solo la chiave a brugola fornita nel pacco e un cacciavite. Per evitare di danneggiare il prodotto, non utilizzare l'avvitatore per serrare le viti. Nel caso in cui il vostro fasciatoio è previsto di rulli, questi devono essere fissati prima dell'uso.

Notare che:

Utilizzare solo accessori e ricambi originali del produttore o del fornitore. Il fasciatoio deve essere fissato alla parete.

**DIESE WICKELKOMMODE ENTSPRICHT DEN EUROPÄISCHEN NORMEN / THIS CHANGING UNIT
COMPLIES WITH THE EUROPEAN NORMS / CETTE COMMODE EST CONFORME AUX NORMES
EUROPÉENNES / QUESTO PRODOTTO CORRISPONDE ALLE NORME EUROPEE:**

DIN EN 12221-1: 2008+A1:2013^A

DIN EN 12221-2: 2008+A1:2013^A

**Für Kinder bis 15 kg! • For children weighing less than 15 kg (33 lbs)! • Pour les enfants pesant moins
de 15 kg ! • Per bambini di max. 15 kg !**

WARNUNG / WARNING

- **Lassen Sie Ihr Kind nicht unbeaufsichtigt!**
- **Do not leave your child unattended!**
- **Ne jamais laissez votre enfant sans surveillance!**
- **¡No dejen el niño con falta de vigilancia!**
- **Non lasciare mai il bambino incustodito!**
- **Laat uw kind nooit zonder toezicht!**





Warnhinweise

Bestimmungsgemässer Gebrauch:

Bitte achten Sie darauf, dass Ihre Möbel nur Ihrem Zweck gemäss verwendet werden. Für eine dauerhafte Funktionsfähigkeit ist eine sachgerechte Nutzung und regelmässige Unterhaltspflege sehr wichtig.

Mises en garde

Utilisation conforme:

Veillez vous assurer que vos meubles sont utilisés uniquement pour leur usage prévu. Un entretien régulier et une utilisation conforme sont essentiels pour assurer un fonctionnement durable.

Avvertenze

Utilizzo per lo scopo previsto:

assicuratevi che i vostri mobili siano utilizzati solo per lo scopo per cui sono stati realizzati. Per garantire il loro funzionamento nel tempo è importante utilizzarli correttamente e sottoporli regolarmente a cure manutentive.

Warning notice

Intended use:

Please make sure that you only use your furniture for the purpose it was designed for. Correct use and regular maintenance are essential for ensuring your furniture remains in working order for the long-term.

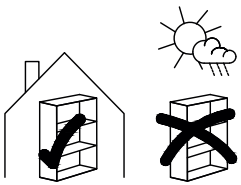

Anwendung:

Das von Ihnen erworbene Behältnismöbel eignet sich für den allgemeinen, privaten Wohnbereich. Es ist nicht für den Nass-, Aussen- oder gewerblichen Bereich geeignet.

Usage:

Le meuble de rangement que vous avez acheté convient pour l'habitat privé en général. Il ne convient pas pour l'extérieur, les milieux humides ou le domaine commercial.

Impiego:

il mobile contenitore acquistato è adatto per un utilizzo in generale, in ambiente domestico. Non è adatto per gli esterni, per l'esposizione alla pioggia o per ambienti commerciali.

Area of use:

The storage furniture you have purchased is suitable for use in general private living quarters. It is not suitable for areas that are wet, outside or used for commercial purposes.



WARNUNG

Verschluck- und Erstickungsgefahr:

Kleinteile und Verpackungsmaterial können verschluckt werden.

AVERTISSEMENT

Risque d'ingestion et d'étouffement:

Les petites pièces et le matériel d'emballage peuvent être avalés.

AVVERTENZA

Pericolo di ingestione e soffocamento:

piccole parti e materiale di imballaggio possono essere ingerite.

WARNING

Risk of swallowing and choking:

Small parts and packaging material may be swallowed.



WARNUNG! Tüten und Folien sind kein Spielzeug! Bitte von Babys und Kleinkindern fernhalten! Nicht über den Kopf ziehen; Erstickungsgefahr!

AVERTISSEMENT! Les sacs et films ne sont pas des jouets! Veuillez les tenir hors de portée des bébés et jeunes enfants! Ne pas mettre sur la tête, risque d'étouffement!

AVVERTENZA! Sacchetti e pellicole non sono un giocattolo! Tenere lontano dalla portata dei neonati e dei bambini piccoli! Non metterli in testa, pericolo di soffocamento!

WARNING! Bags and film coverings are not toys! Please keep away from babies and small children! Do not put them over your head, risk of suffocation!



VORSICHT,

Verletzungsgefahr:

Kleinkinder dürfen sich nicht im Montage-Bereich aufhalten und an Möbeln hochziehen oder hinaufklettern.

PRÉCAUTION,

risque de blessures:

Les jeunes enfants ne peuvent pas se tenir dans la zone de montage ni tirer ou grimper sur des meubles.

PRECAUZIONE,

pericolo di lesioni:

tenere i bambini lontano dal luogo di montaggio e evitare che si appendano o arrampichino sul mobile.

PRECAUTION,

risk of injury:

Small children must keep away from the assembly area. They must refrain from climbing up on the furniture.



1.

Allgemeine Hinweise

Remarques générales

Avvertenze generali

General information

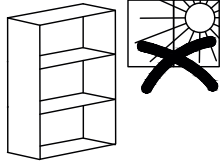

ACHTUNG
Direkte Sonneneinstrahlung:
Führt zu Farbveränderungen.

ATTENTION
Exposition directe au soleil:
Provoque des décolorations.

ATTENZIONE
Irraggiamento diretto del sole:
ne modifica il colore.

ATTENTION
Direct sunlight:
results in discolouration.

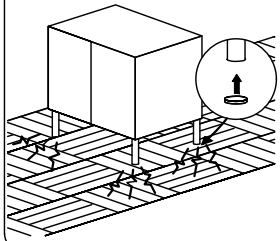

Schutzgleiter:
Mit Schutzgleitern (z.B. aus Filz), lassen sich Schäden auf kratzempfindlichen Böden (z.B. Parkett) vermeiden.

Patins:
Les patins (p.ex. en feutre) permettent d'éviter d'endommager les sols sensibles aux rayures (p.ex. parquet).

Scivolante protettivo:
grazie agli scivolanti protettivi (ad es. feltro) si evita di danneggiare pavimenti sensibili ai graffi (ad es. parquet).

Protective covers:
Protective covers, e.g. felt pads, prevent damage to floors that are easily scratched (e.g. parquet).

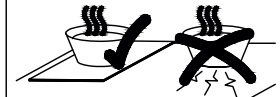

ACHTUNG, Temperatur:
Nie heiße oder sehr kalte Objekte direkt auf die Oberfläche stellen. Geeigneten Schutz verwenden, z.B. Untersteller.

ATTENTION, température:
Ne jamais poser des objets chauds ou très froids directement sur la surface. Utiliser une protection appropriée, p.ex. sous-plat.

ATTENZIONE, temperatura: non appoggiare mai oggetti caldi o molto freddi direttamente sulla superficie. Utilizzare una protezione adatta, ad es. un sotto piatto.

ATTENTION, temperature:
Do not place hot or cold objects directly on the surface. Use the appropriate protection, e.g. saucer.

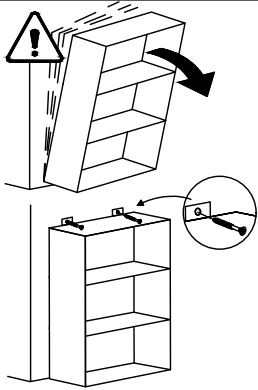

VORSICHT, dieses Möbel kann Kippen.
Um dies zu verhindern, muss es mit Kippsicherung(en) an der Wand / Decke befestigt werden. Die Befestigung ist abhängig von der Wand-/ Deckenbeschaffenheit (z.B. Beton/Gips/Backstein/Holz) und muss von einem Fachmann ausgeführt werden.

PRÉCAUTION, ce meuble peut basculer.
Pour empêcher cela, il doit être fixé au mur/plafond avec une sécurité anti-basculement. La fixation dépend de la nature du mur/plafond (p.ex. béton/plâtre/brique/bois) et doit être réalisée par un spécialiste.

PRECAUZIONE, questo mobile può ribaltarsi.
Per evitare questo, deve essere adeguatamente fissato alla parete o al soffitto. Il tipo di fissaggio dipende dalle caratteristiche della parete o del soffitto (ad es. cemento/gesso/mattone/legno) e il fissaggio deve essere eseguito da un esperto.

PRECAUTION, this piece of furniture can tip over.
To prevent this it must be secured to the wall or ceiling with brackets. The type of bracket depends on the quality of the wall and/or ceiling (e.g. concrete, plaster, brick, wood) and must be mounted by a specialist.

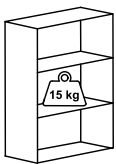

Max. Belastung:
15 kg

Charge max.:
15 kg

Carico max.:
15 kg

Max. load:
15 kg

2.

Montagehinweise

Instructions de montage

Istruzioni di montaggio

Assembly information

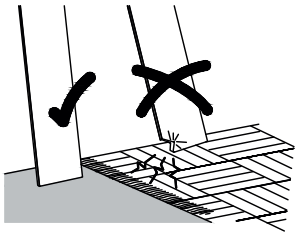

Montageschäden:

Vermeiden Sie, indem Sie einen sauberen und weichen Untergrund verwenden (z.B. Teppich). Teile beim Auspacken oder während der Montage nur auf weiche Unterlagen legen/stellen. Darauf achten, dass grössere Teile nicht kippen können.

Dommages au montage:

Évitez les dommages en utilisant un fond propre et doux (p.ex. tapis). Lors du déballage et montage, posez/placez les éléments uniquement sur un fond doux. Assurez-vous que les grands éléments ne peuvent pas basculer.

Danni in fase di montaggio:

evitare di causare danni utilizzando una base pulita e morbida (ad es. tappeto). Nella fase di disimballaggio e durante il montaggio, appoggiare i pezzi esclusivamente su una base morbida. Fare attenzione che i pezzi più grandi non si ribaltino.

Damages during assembly:

These can be avoided if you use a clean soft surface (e.g. carpet). Only place parts on a soft surface when unpacking or during the assembly. Make sure that larger parts cannot tip over.



Personen:
Für die Montage erforderliche Anzahl Personen.

Personnes:
Nombre de personnes nécessaires au montage.

Persone:
numero di persone necessarie per il montaggio.

People:
Number of people required for the assembly.



1h

Montagerichtzeit:

Ungefähre Zeit in Stunden.

Durée indicative du montage:

Durée approximative en heures.

Tempo di montaggio:

tempo in ore approssimativo.

Assembly time:

Approximate time in hours.

Benötigtes Werkzeug:

Outils nécessaires:

Attrezzi necessari:

Tools required:

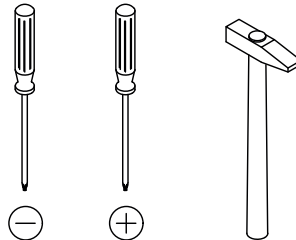

3.

**Montage-
hinweise**

**Instructions de
montage**

**Istruzioni di
montaggio**

**Assembly
information**

Bau-/Kleinteile:

Éléments / pièces:

**Componenti/
piccoli pezzi:**

**Components/
small parts:**

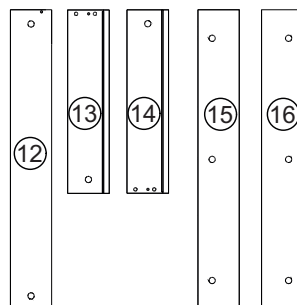
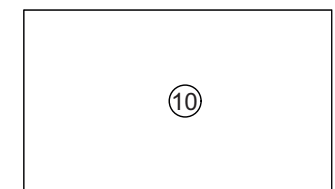
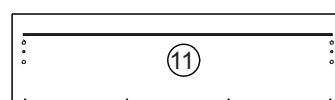
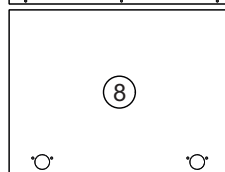
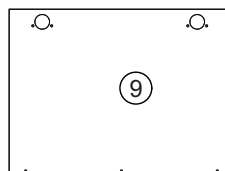
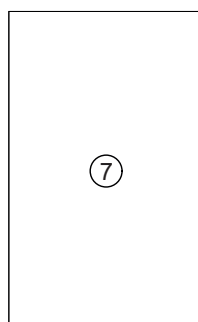
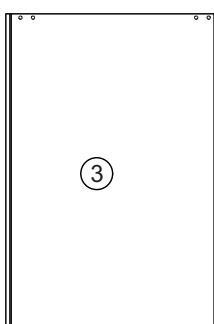
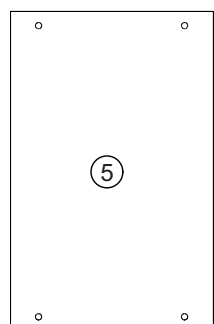
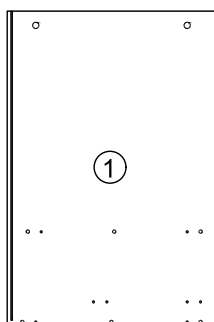
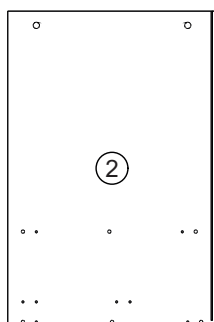
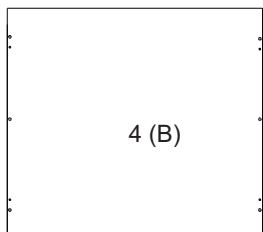
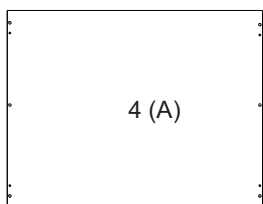

Bau-/Kleinteile:

Éléments / pièces:

**Componenti/
piccoli pezzi:**

**Components/
small parts:**

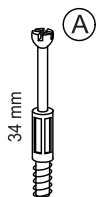

22x



16x



4x

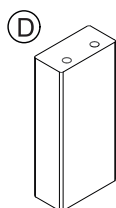

4x

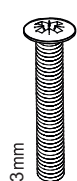

8x

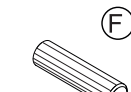

34x



6x

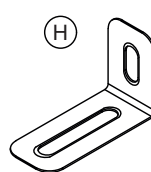

1x



2x



2x



2x

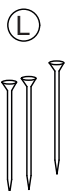

8x



7x

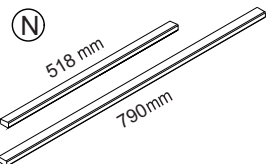

1x

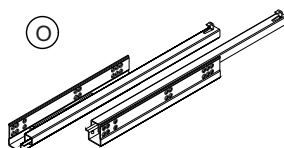

1x

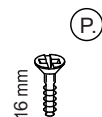

26x

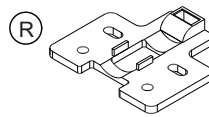
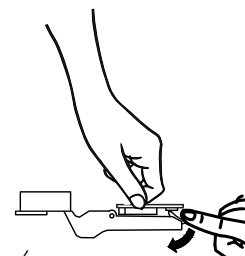

4x

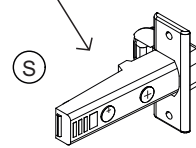

4x

4. **Montage-
anleitung** **Instructions de
montage** **Istruzioni per
il montaggio** **Assembling
instruction**

1

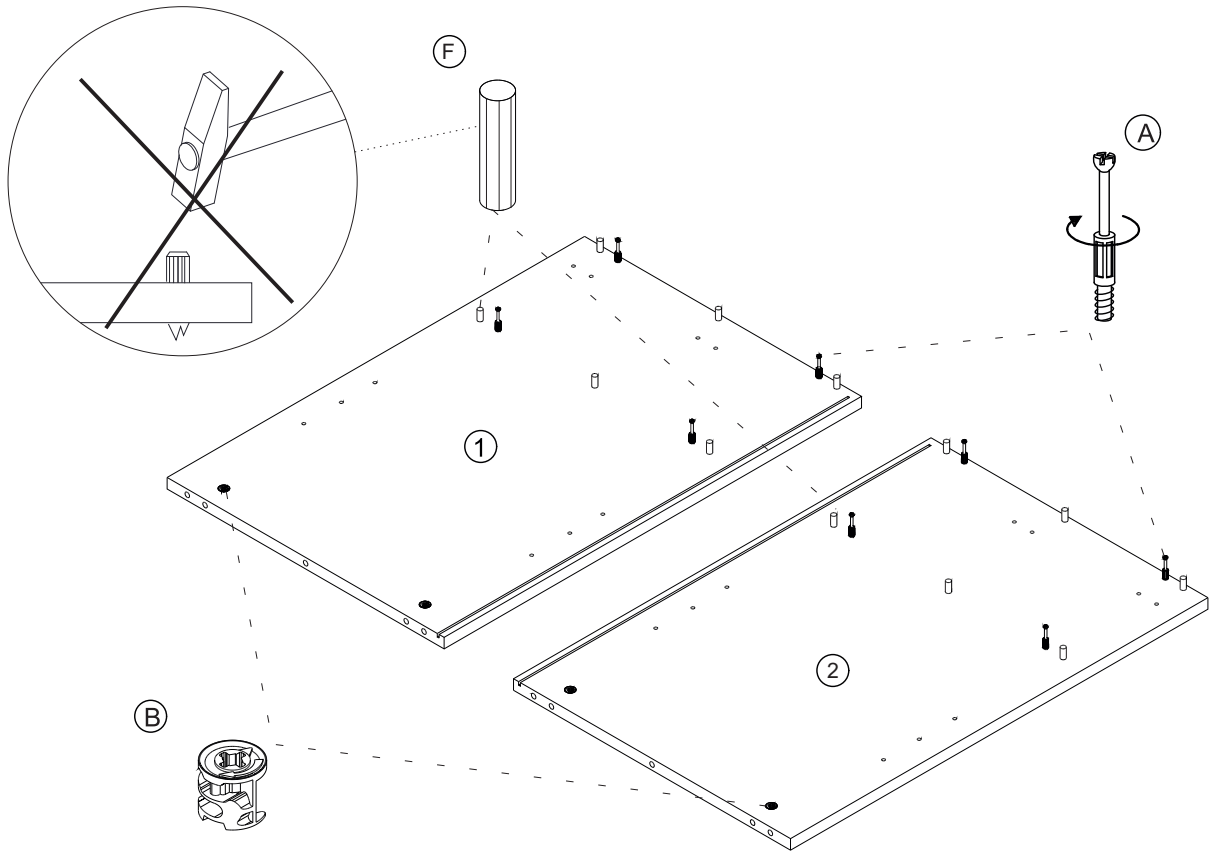

2

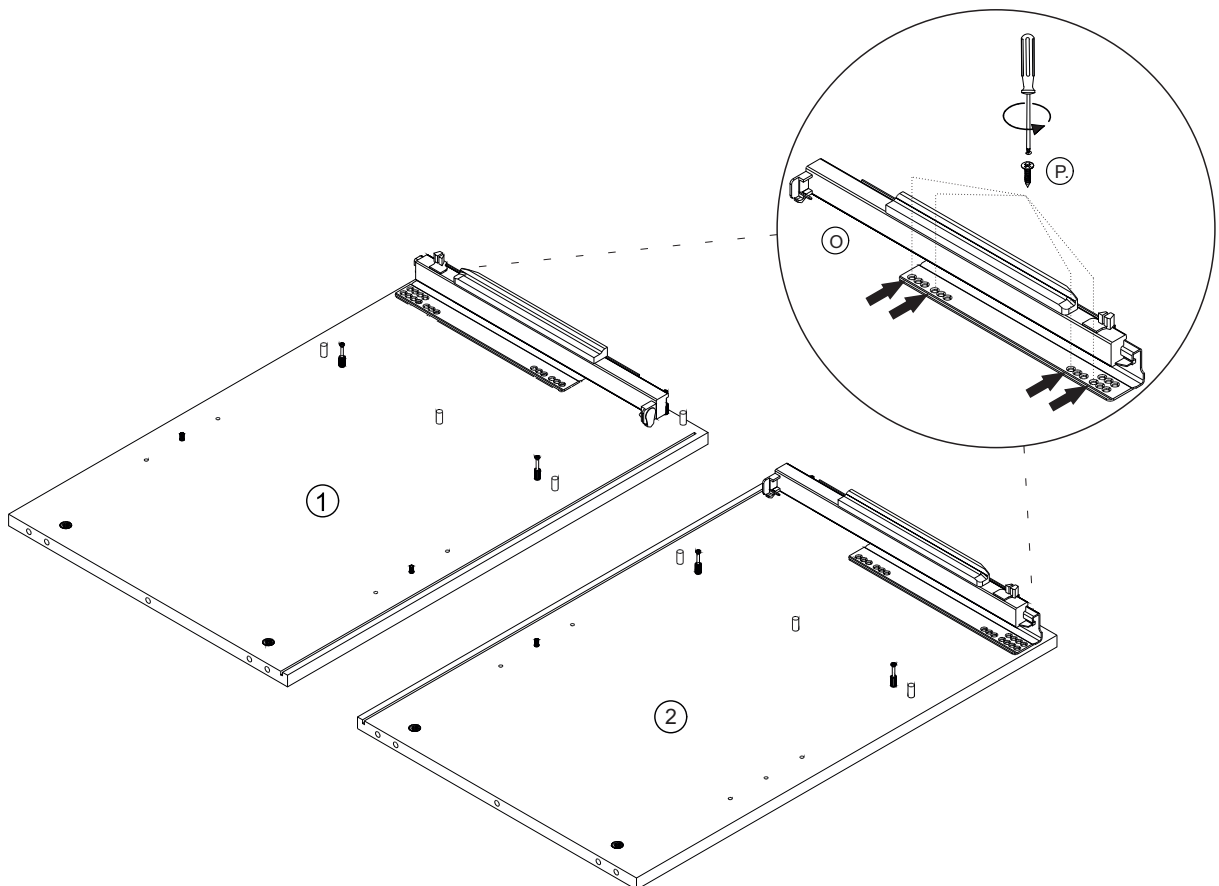

3

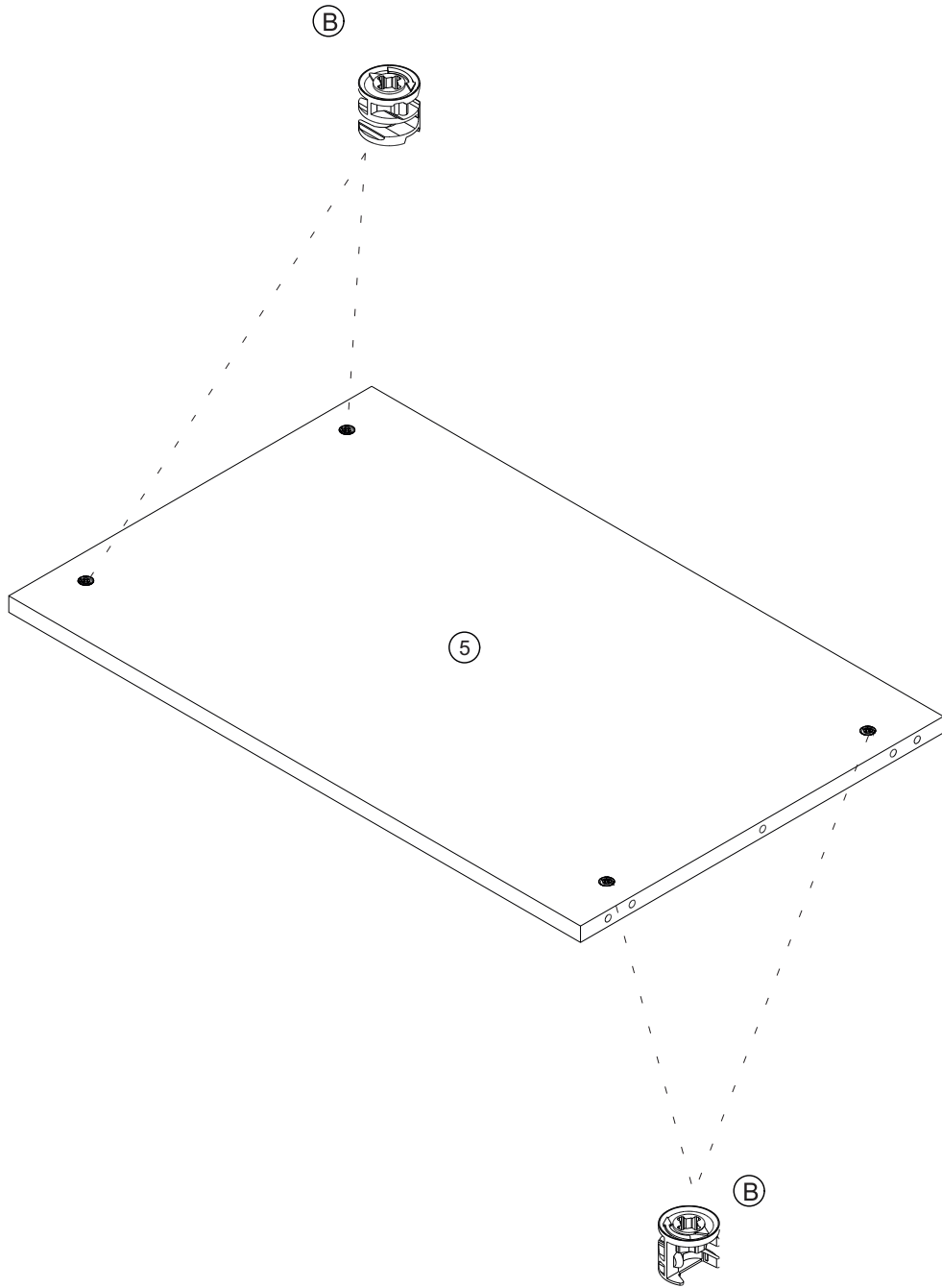

4

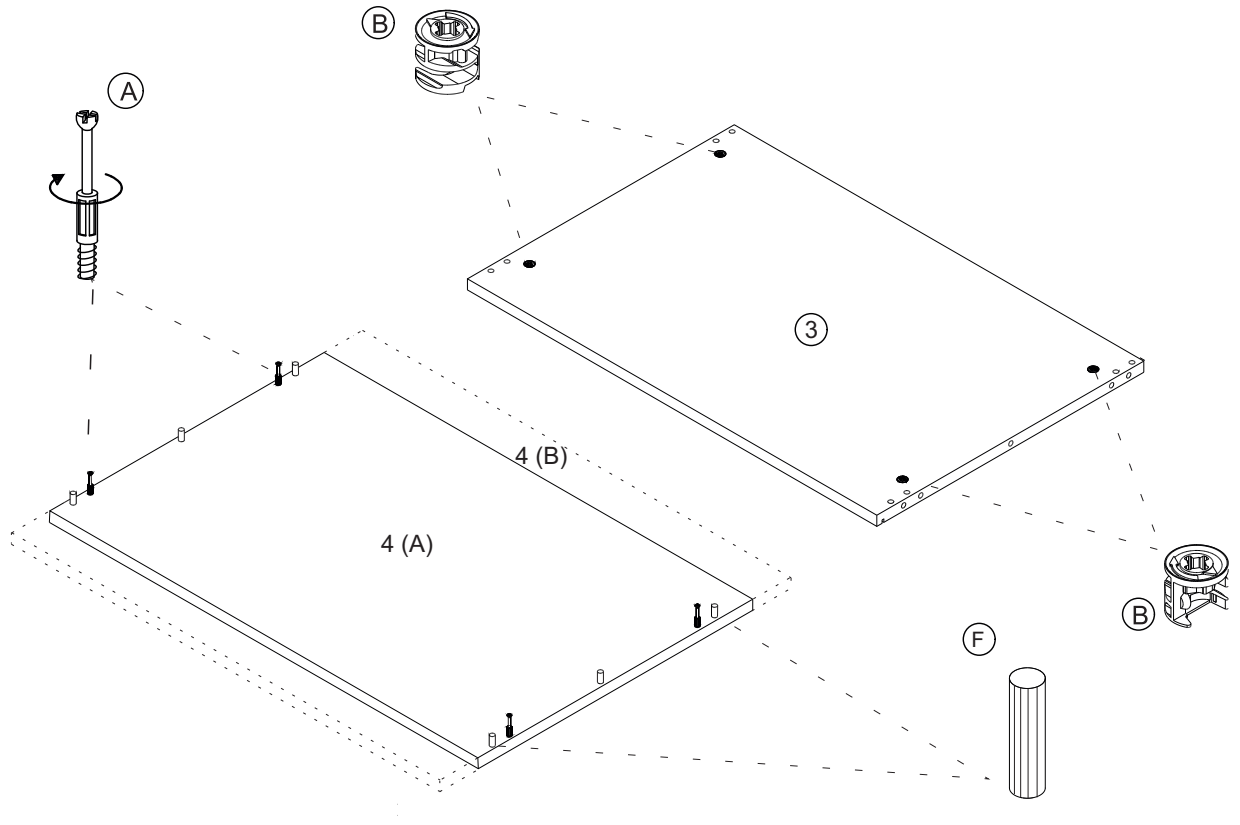

5

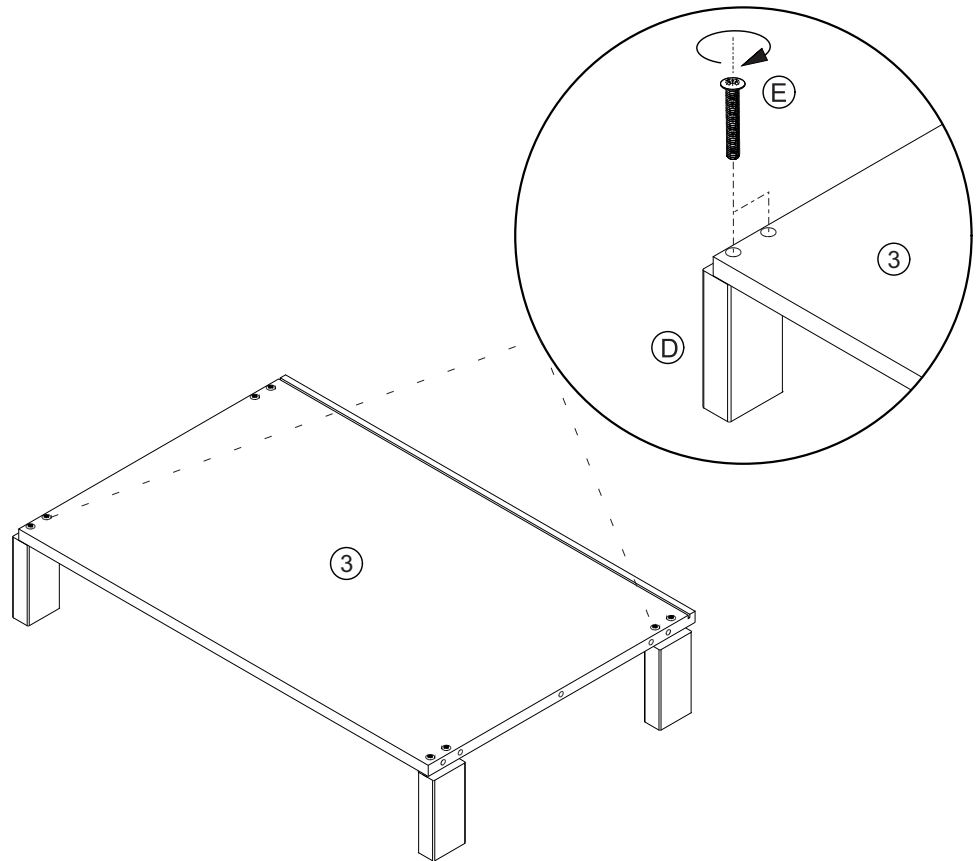

6

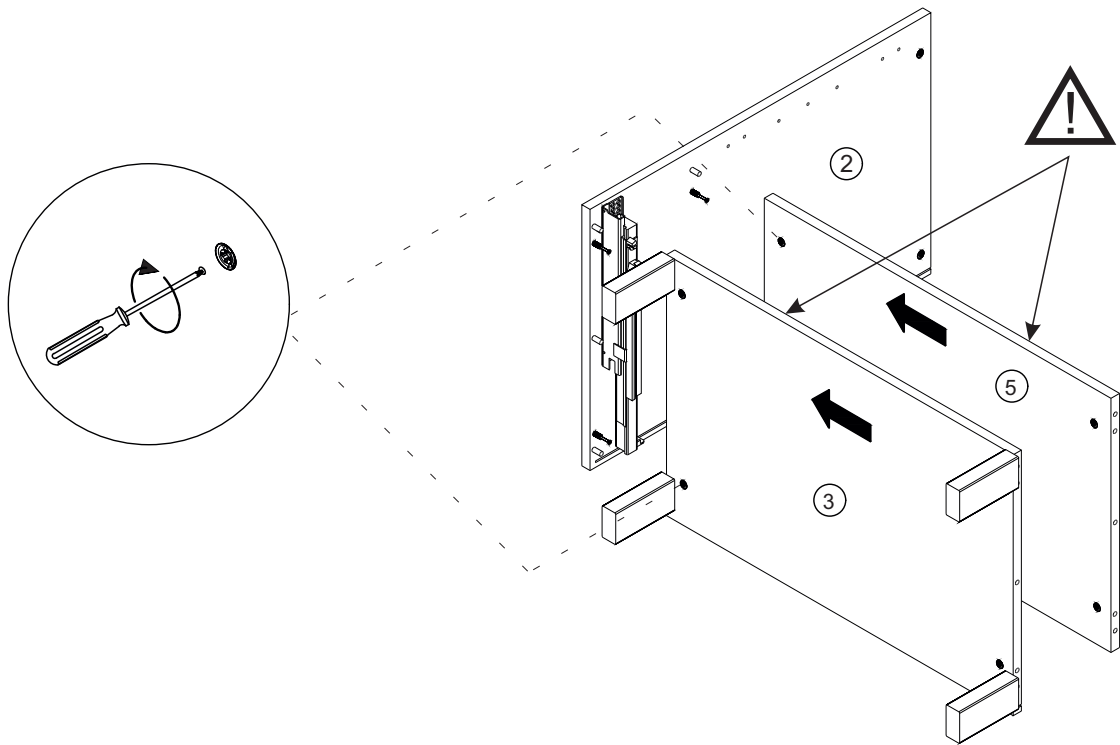

7

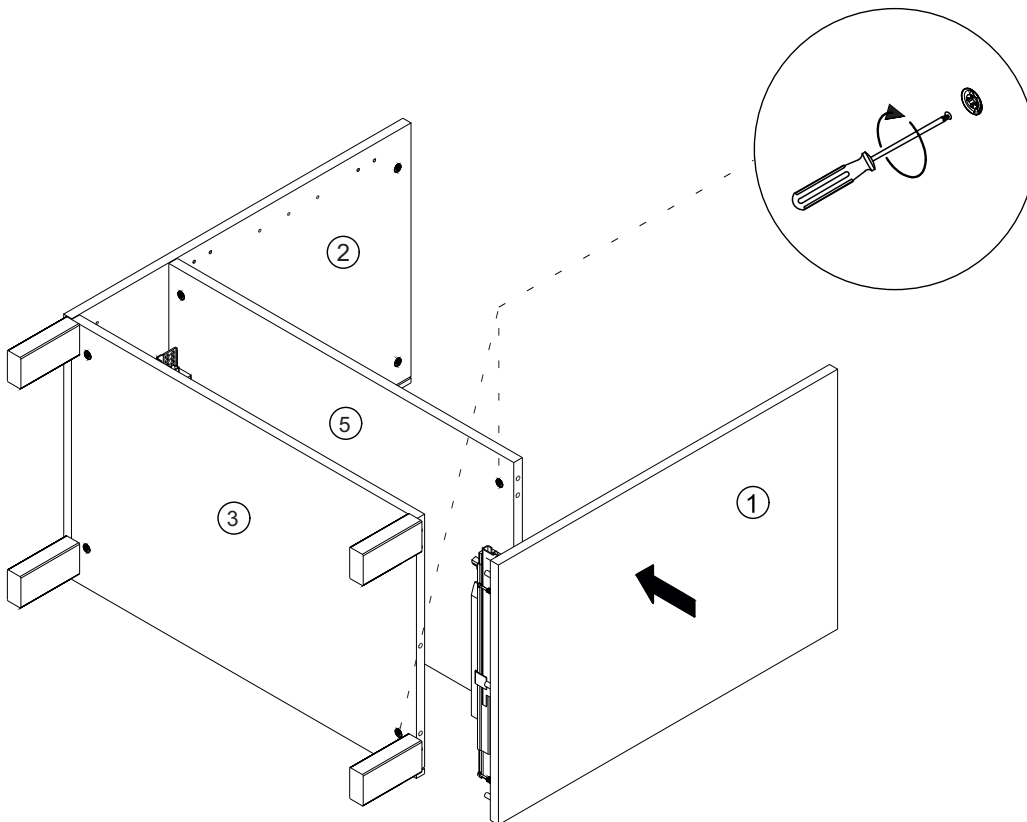

8

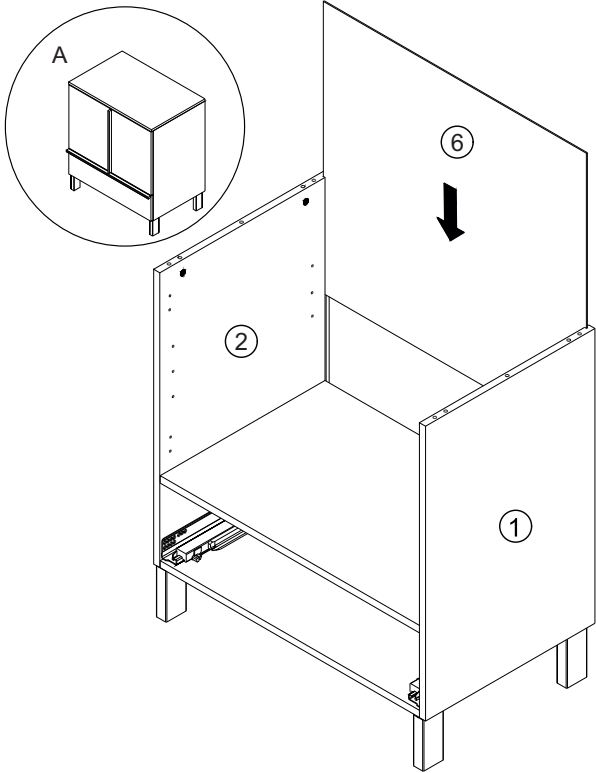

9

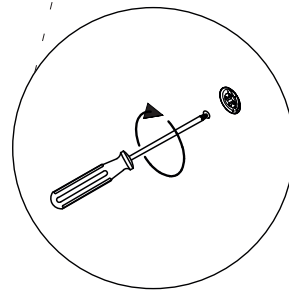
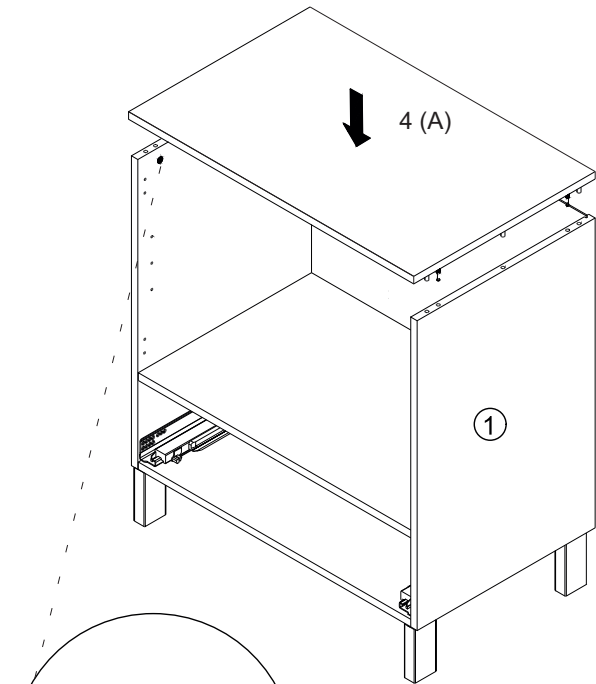

10

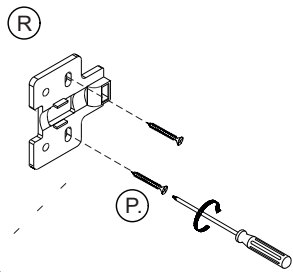

11

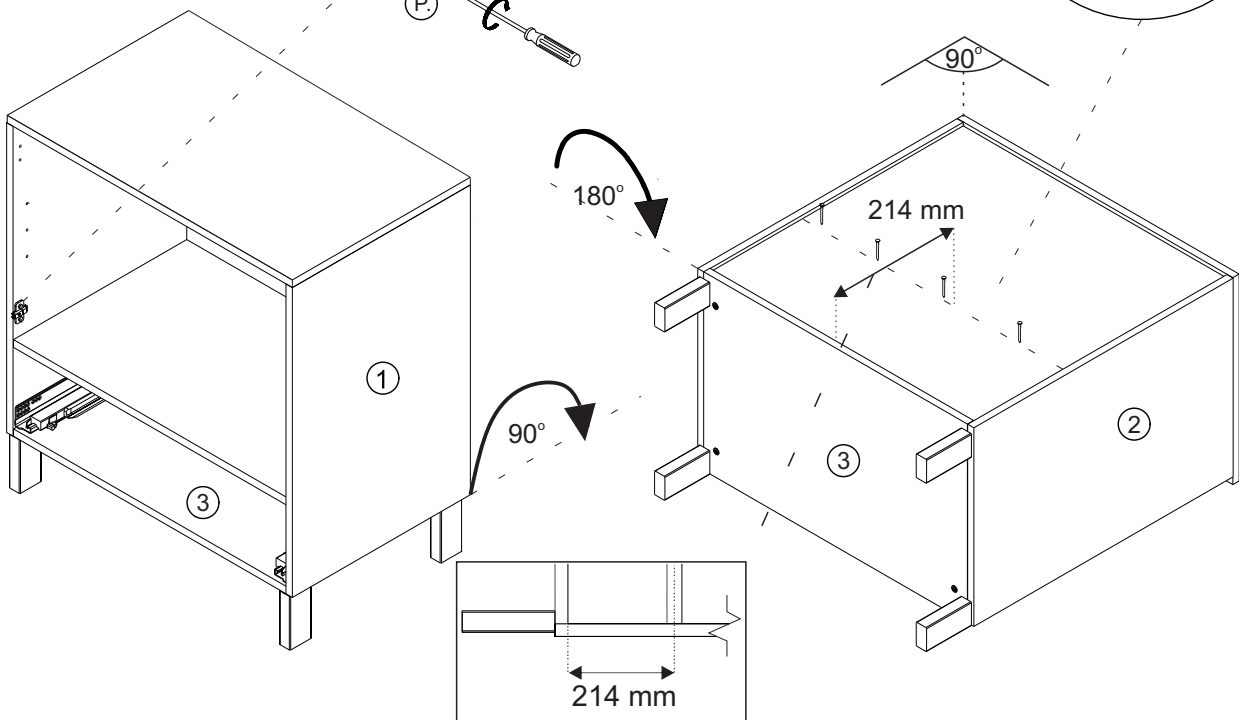
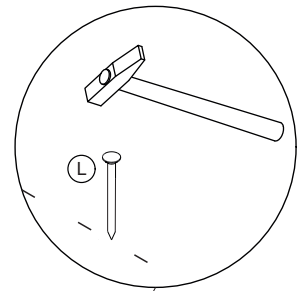

12

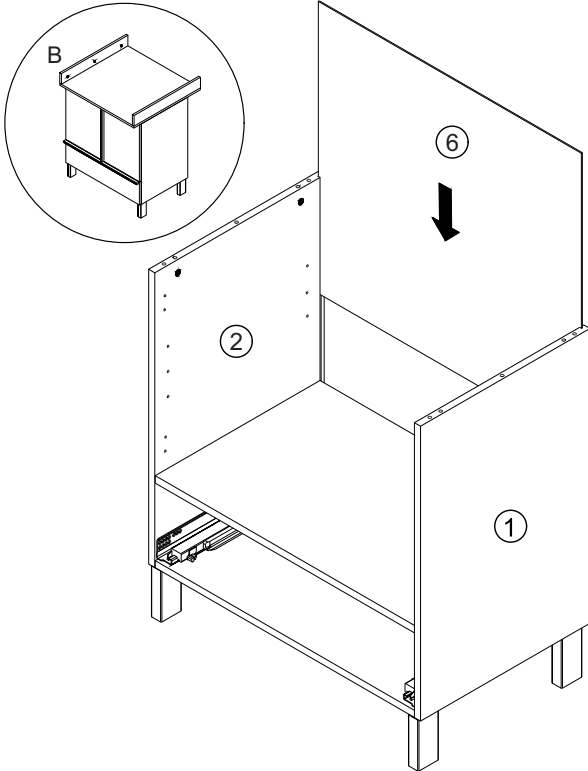

13

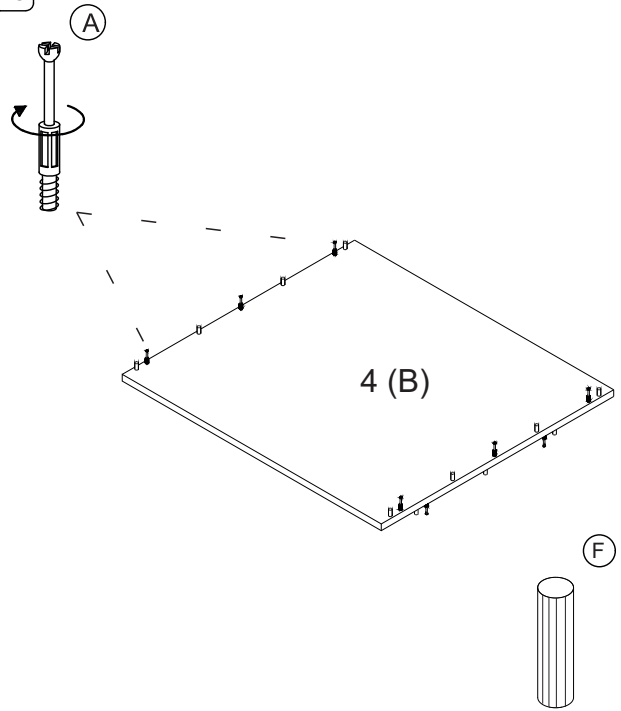

14

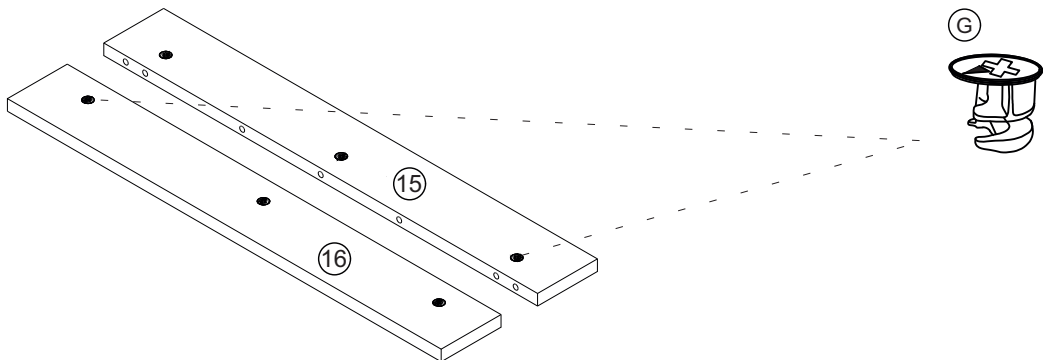

15

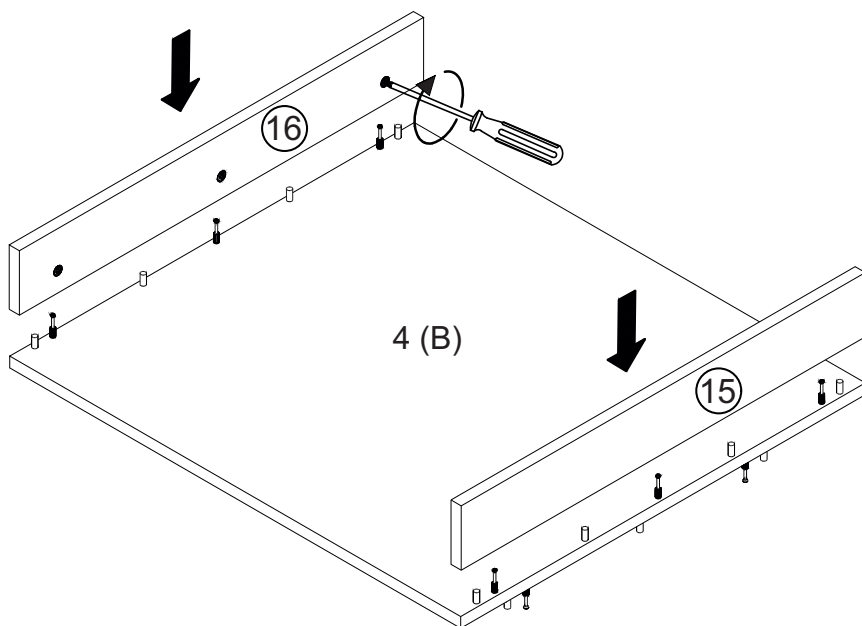

17

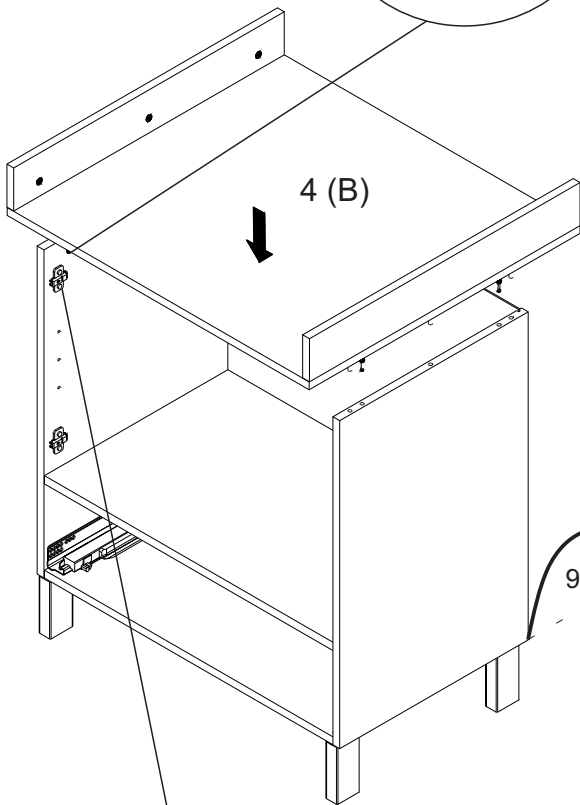
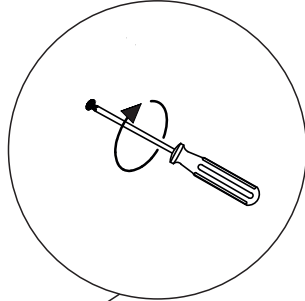
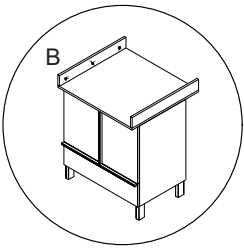

16

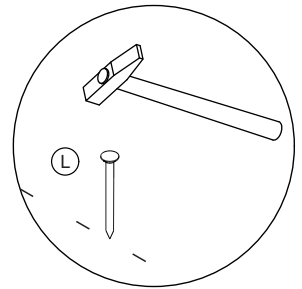
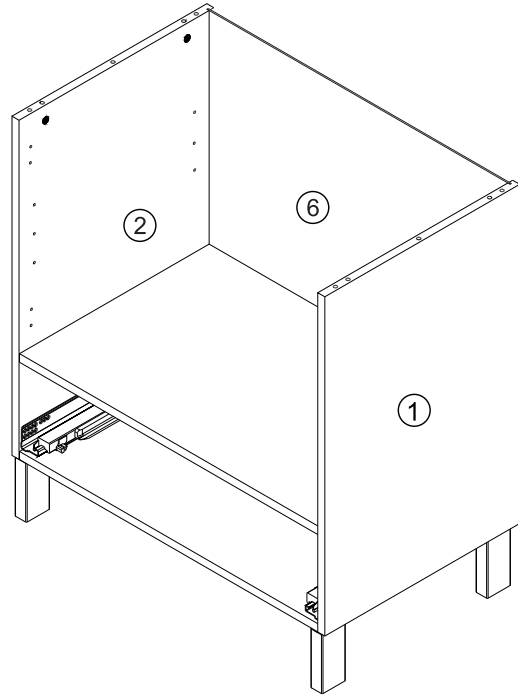

18

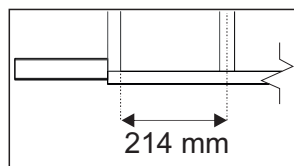
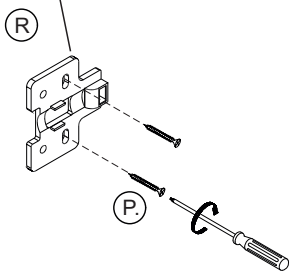
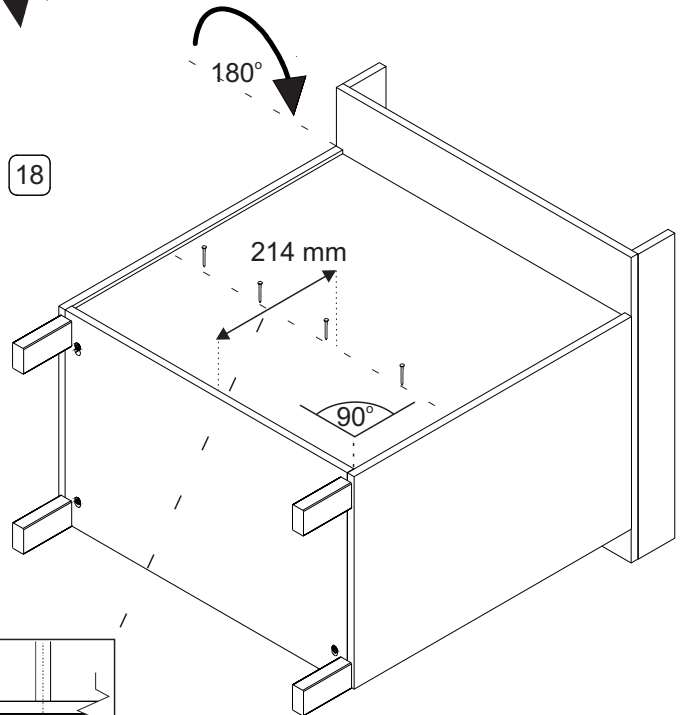

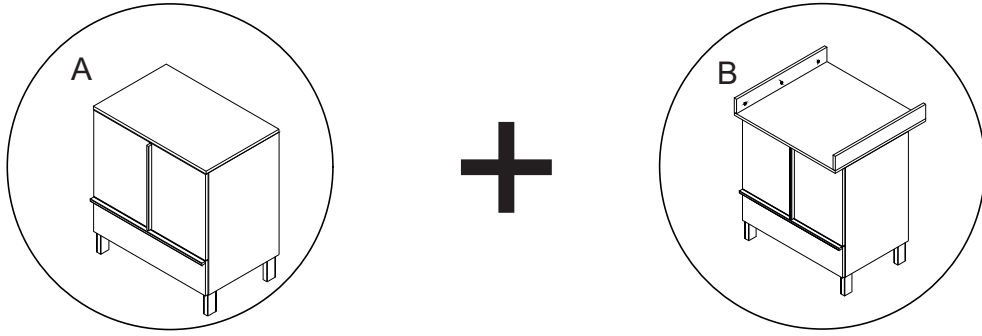

19

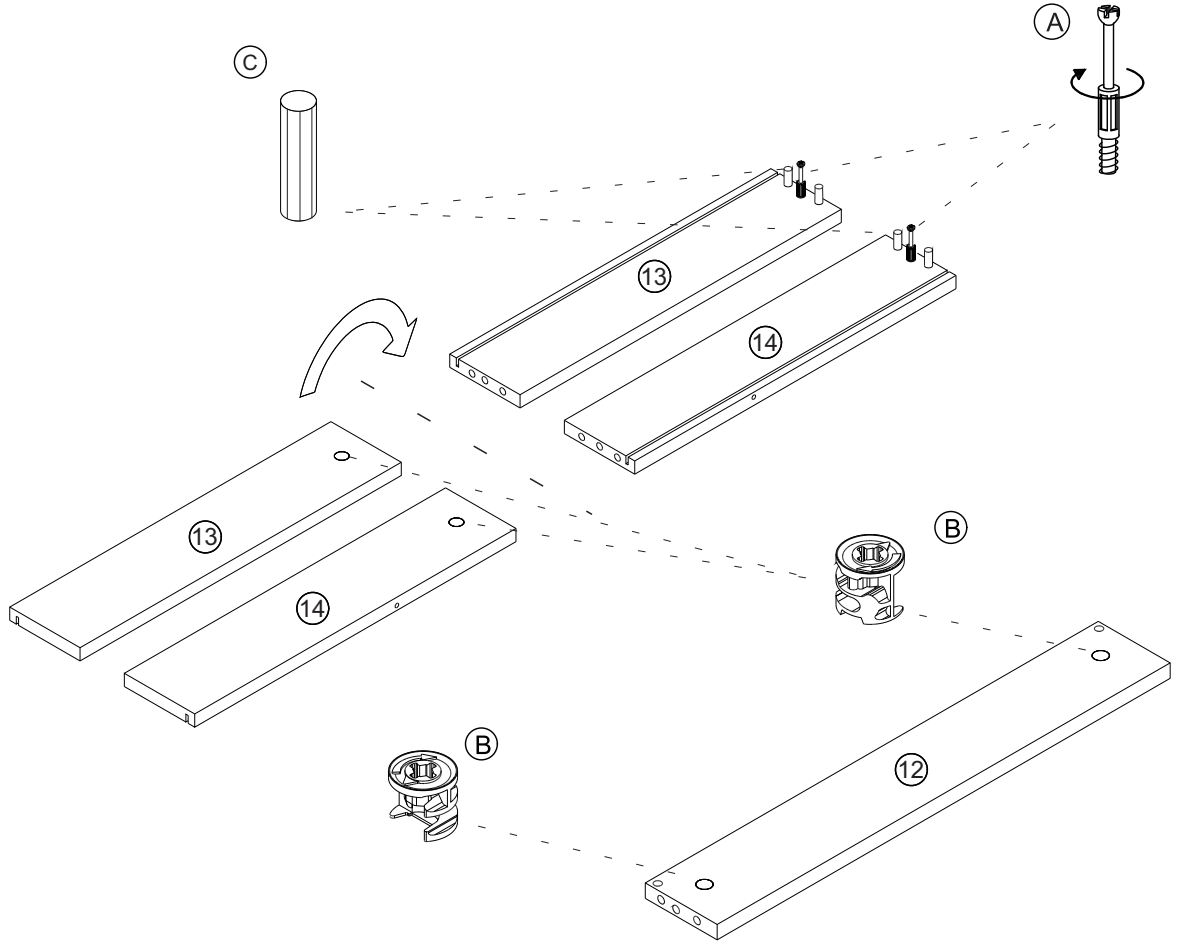

20

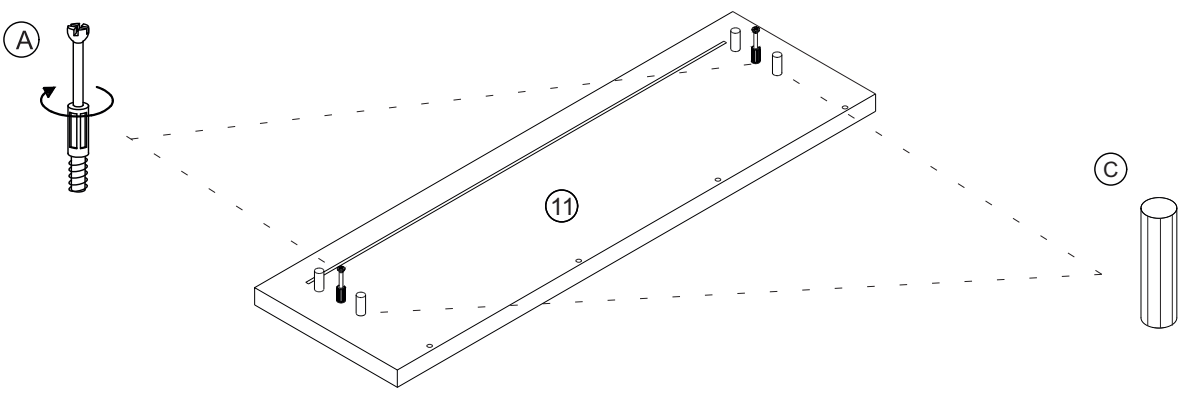

21

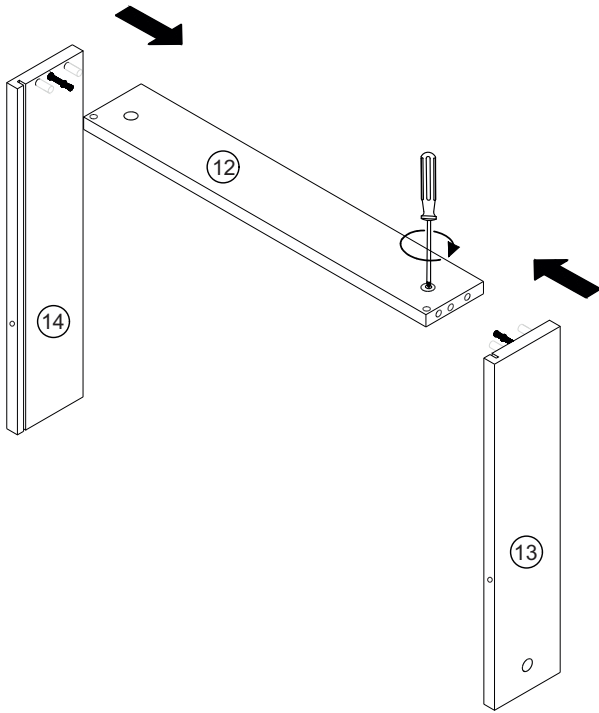

22

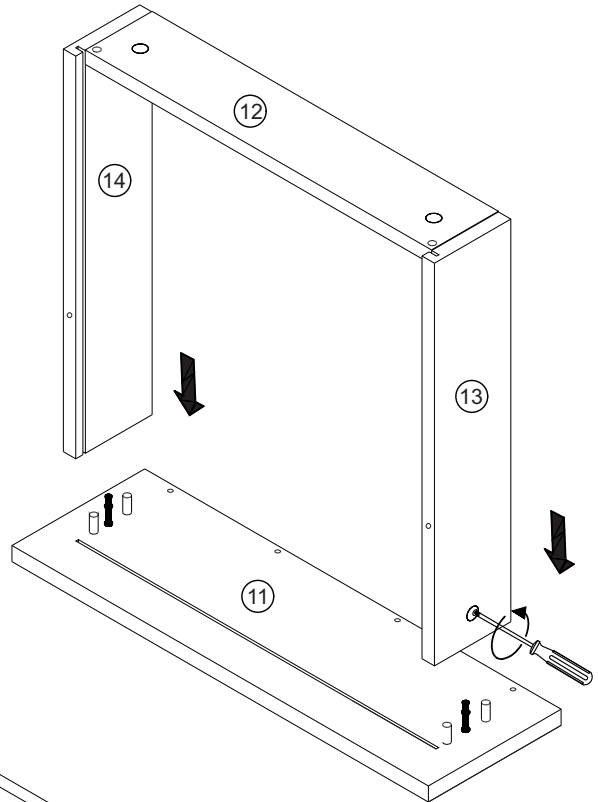

23

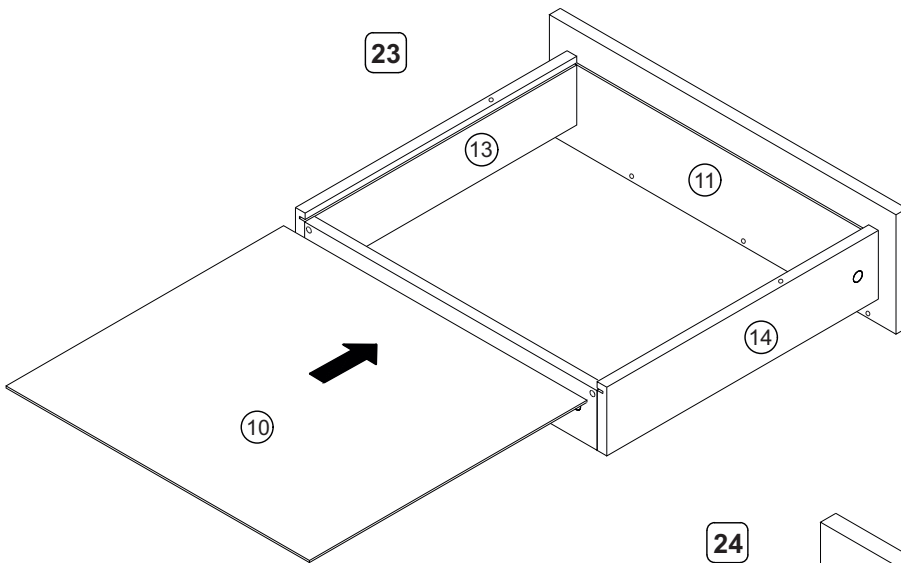

24

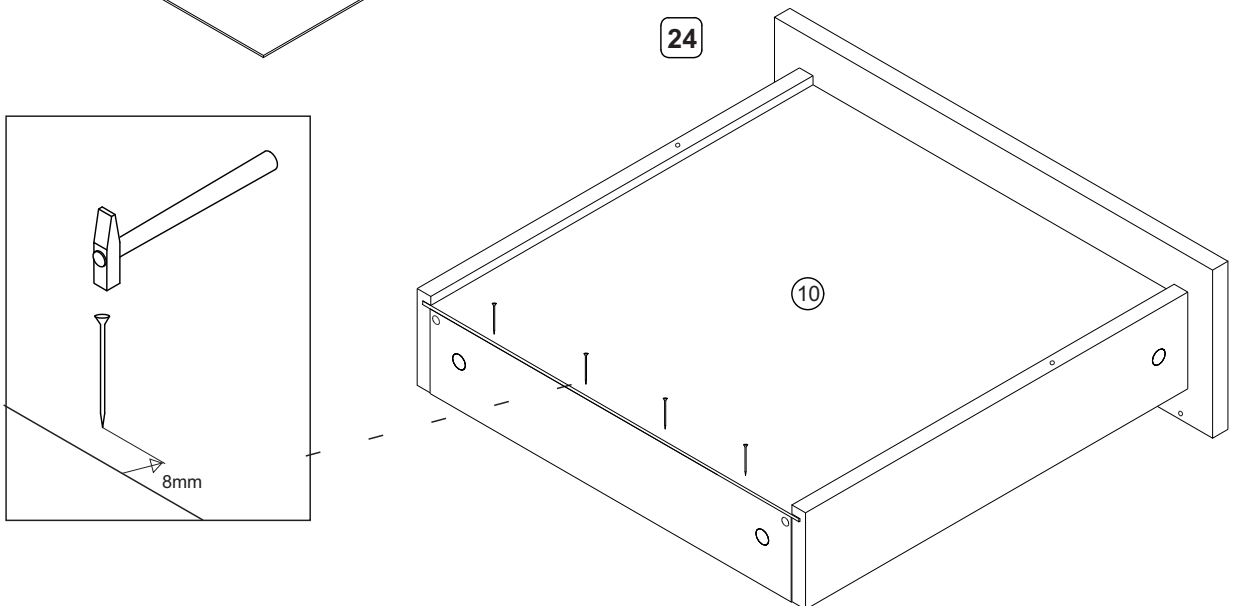

25

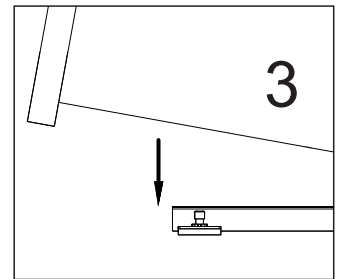
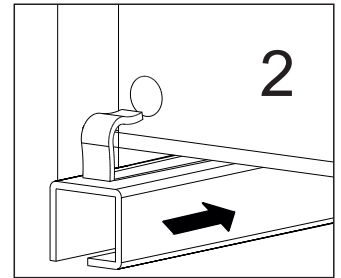
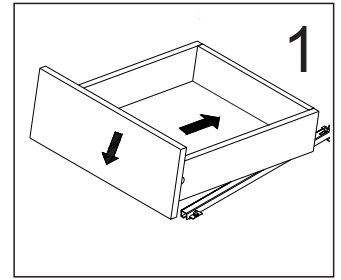
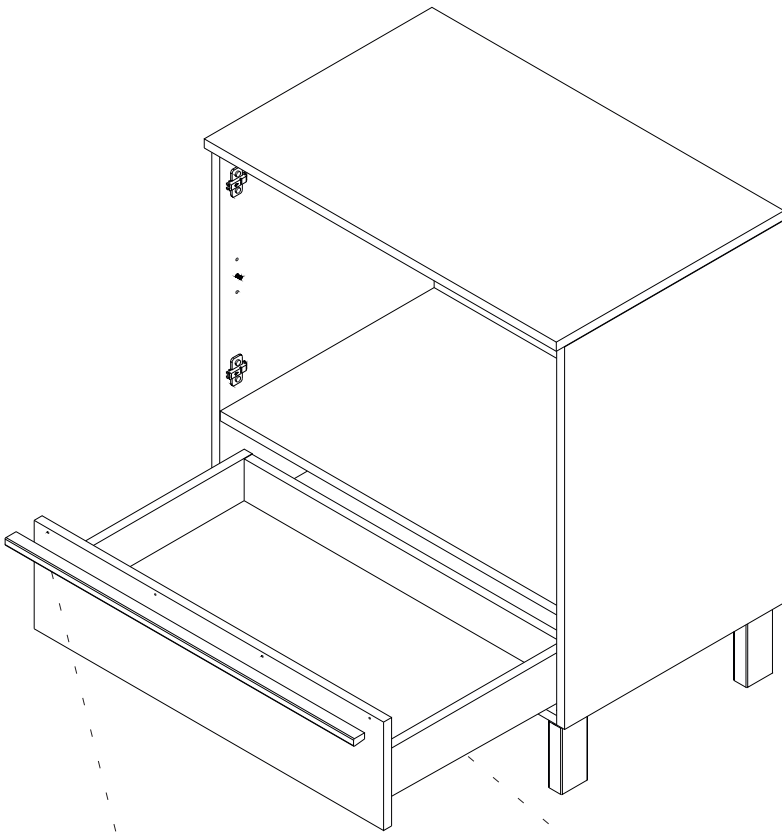

26

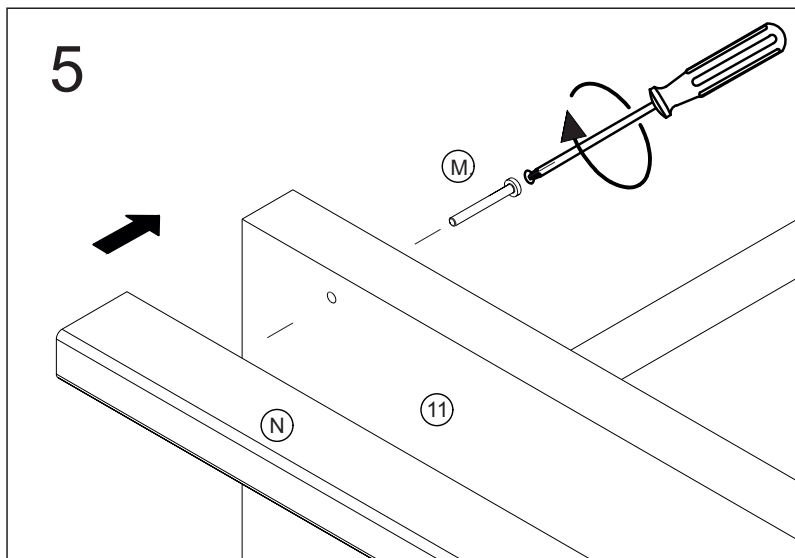
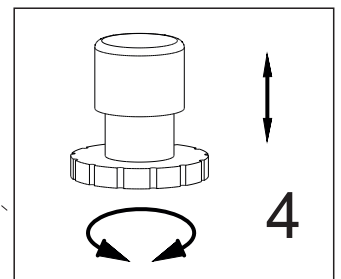

27

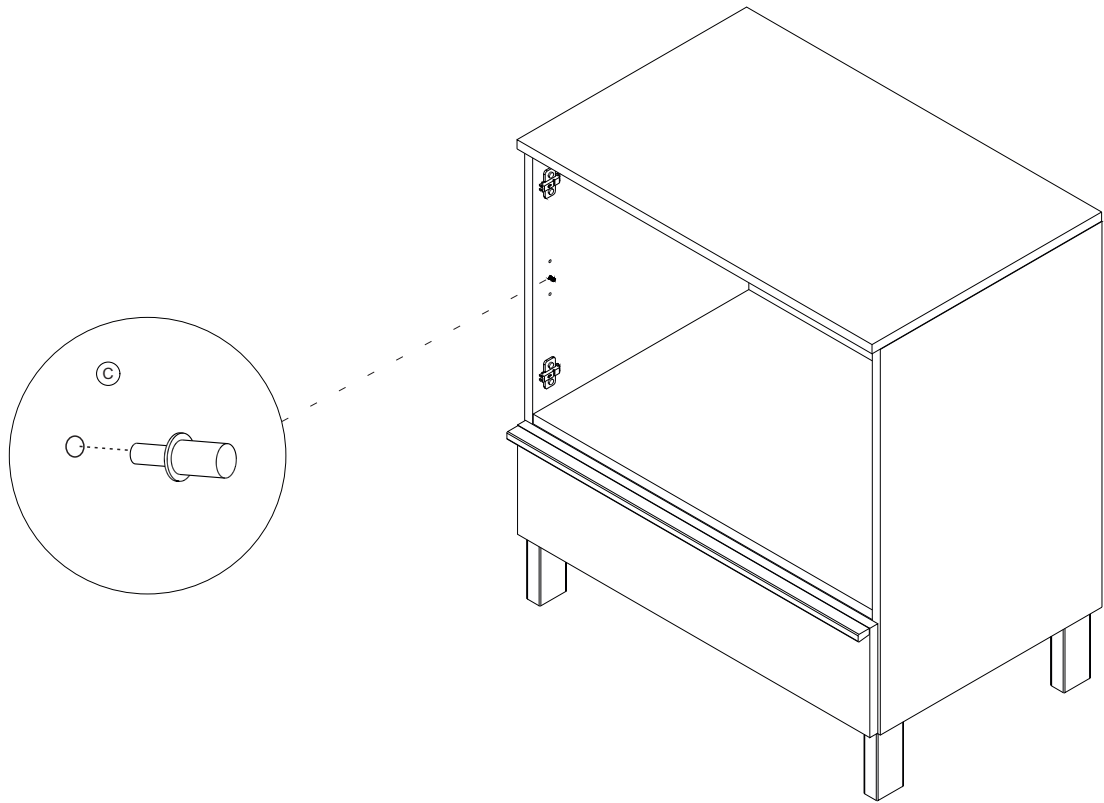

28

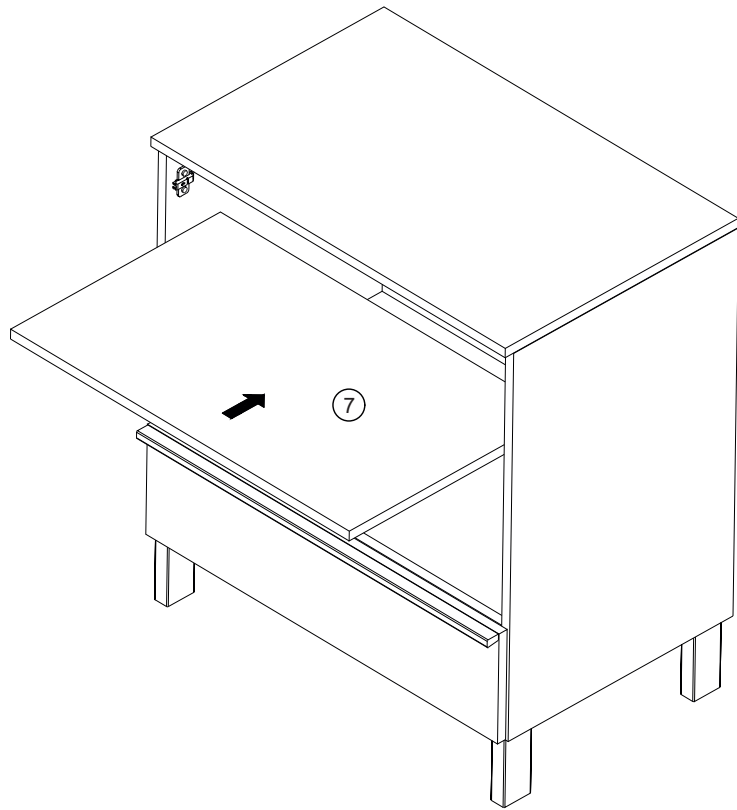

29

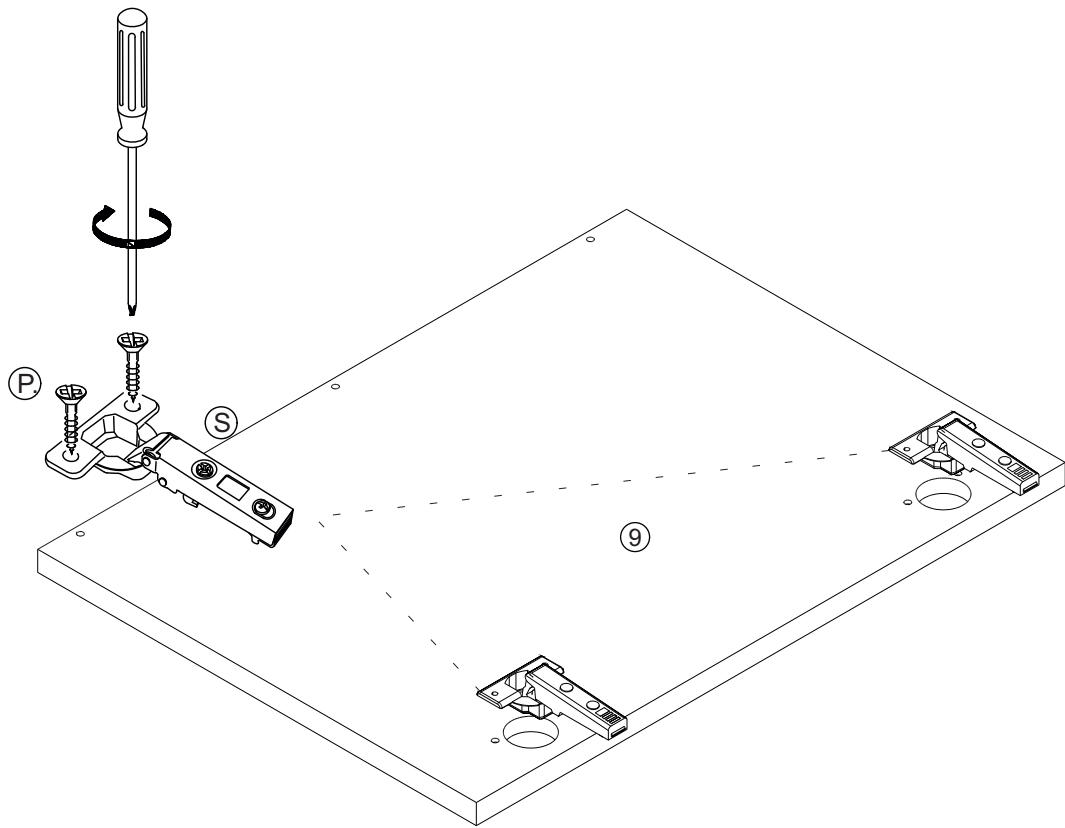

30

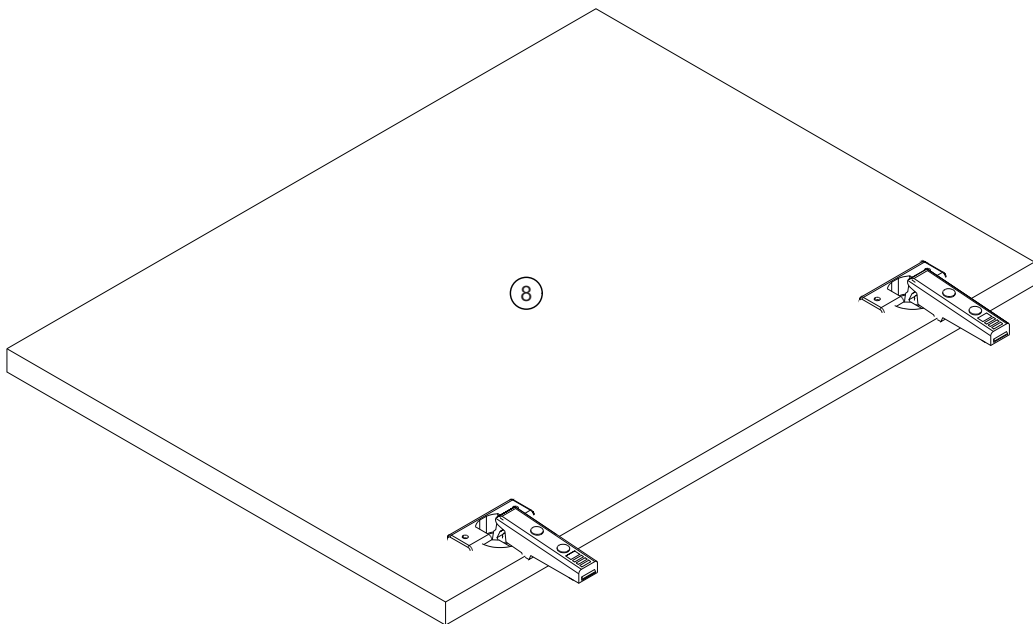

31

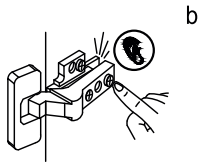
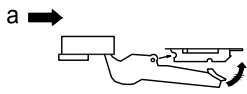
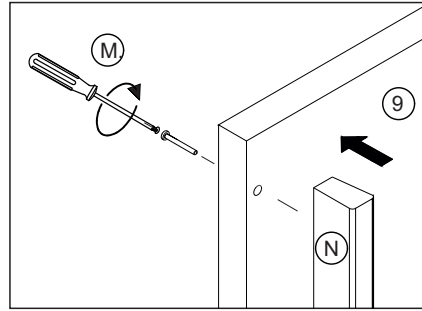
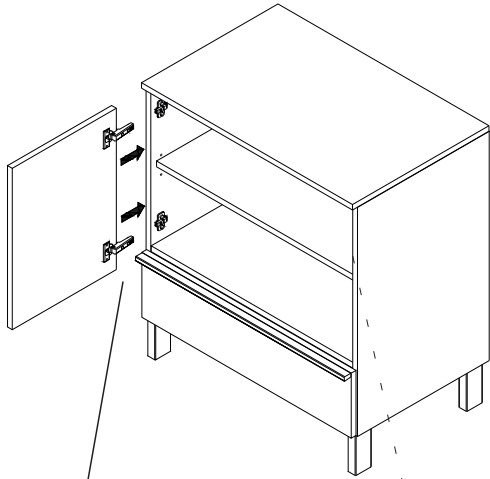

32

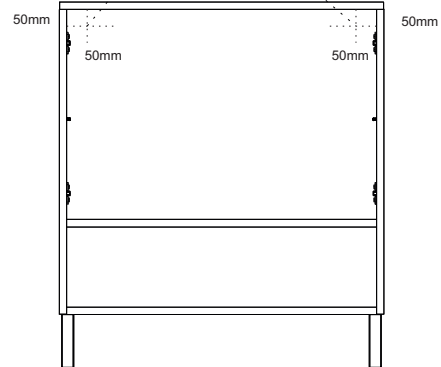
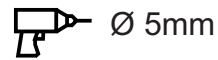
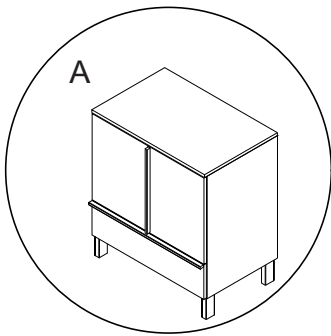
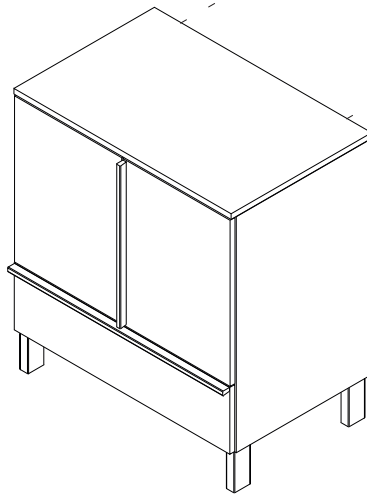

Wandbefestigung erforderlich
 Wall-fixing required
 Fixation mural requis
 Montaggio a parete richiesto
 Requiere montaje en pared
 Bevestiging aan de wand vereist

33

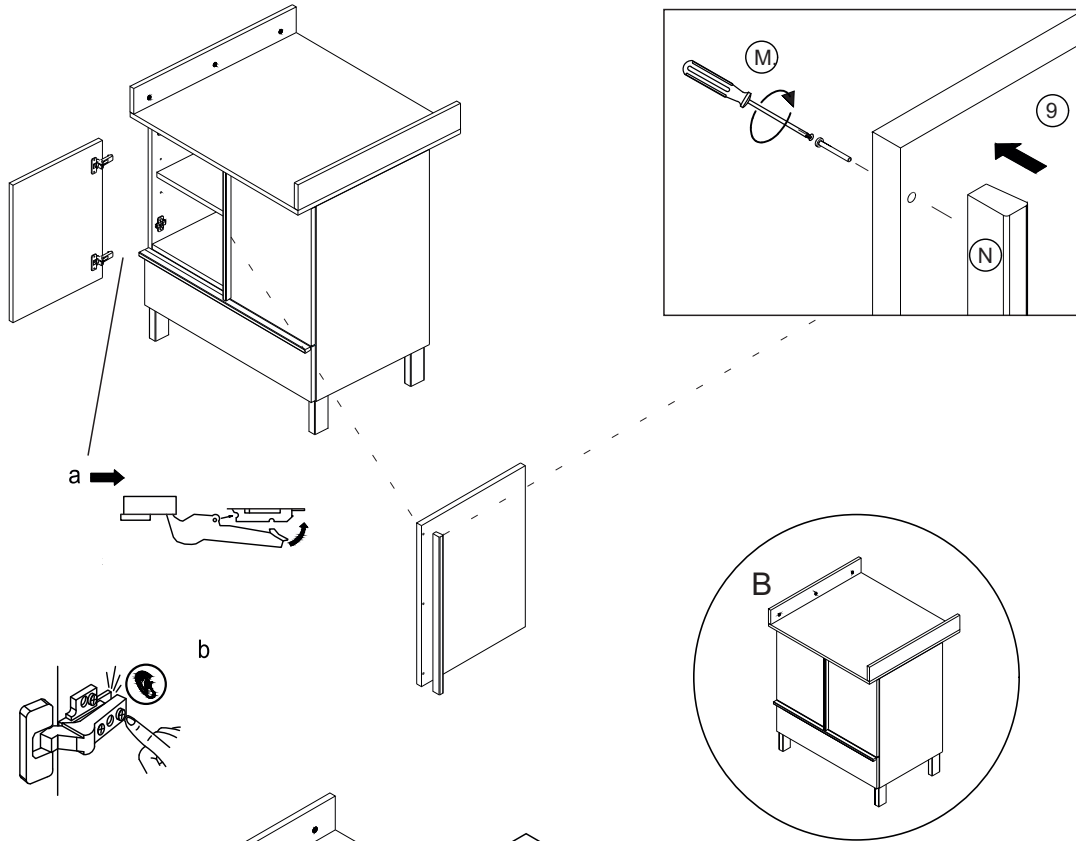

34

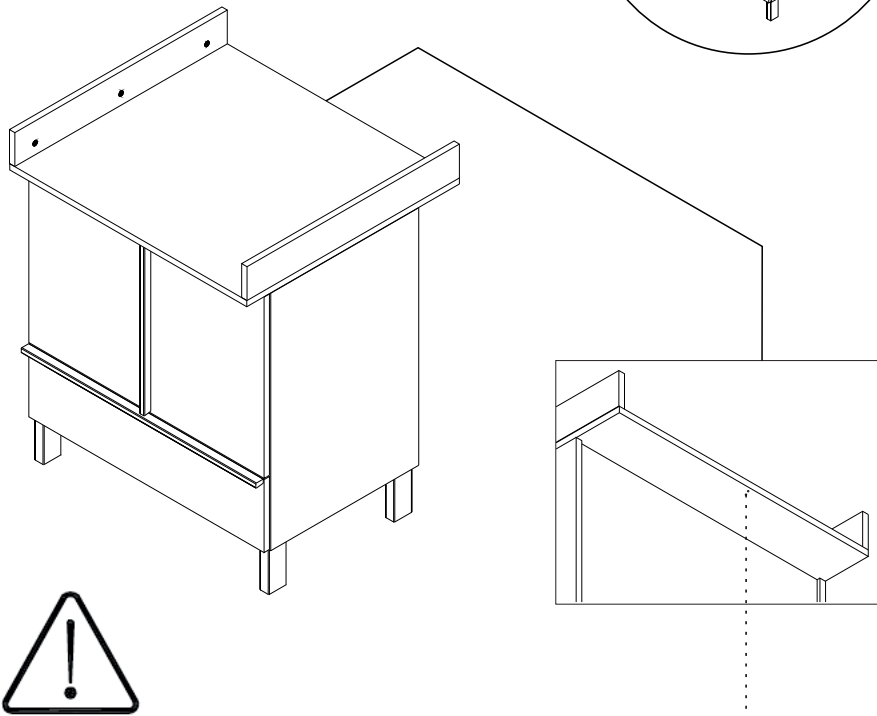

Wandbefestigung erforderlich
 Wall-fixing required
 Fixation mural requis
 Montaggio a parete richiesto
 Requiere montaje en pared
 Bevestiging aan de wand vereist

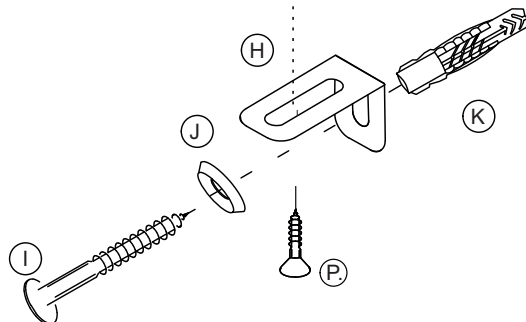

Scharniere:

Für einwandfreie, zuverlässige Funktion Topfbänder und Scharniere regelmäßig kontrollieren und falls nötig justieren (z.B. vierteljährlich).

Charnières:

Pour un fonctionnement sûr et correct, les paumelles et charnières doivent être régulièrement contrôlées et le cas échéant réajustées (p.ex. tous les 3 mois).

Cerniere:

per un funzionamento corretto e sicuro controllare regolarmente le cerniere a tazza e le cerniere in generale e se necessario regolarle (ad es. ogni tre mesi).

Hinges:

To ensure all the hinges and concealed hinges continue to work smoothly, check them regularly and adjust them if necessary (e.g. every three months).

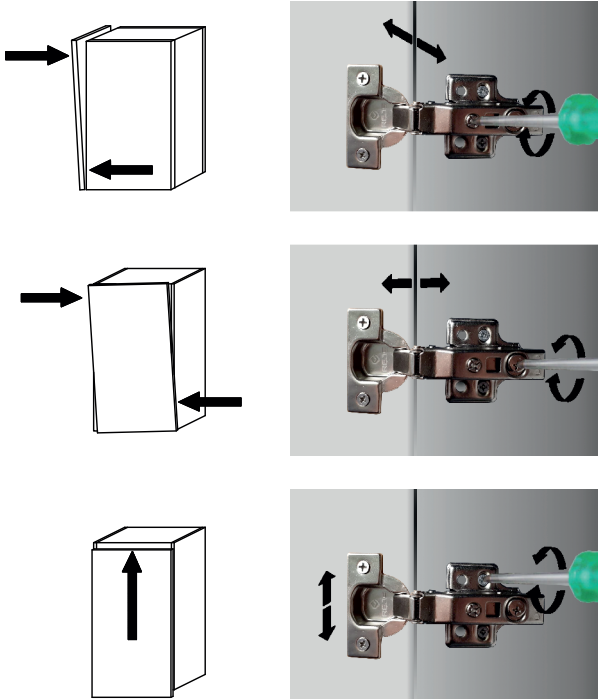

Tür
Door
Porte

a →

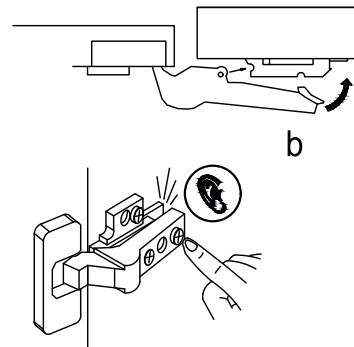

Scharnier lösen
Detach of the hinge
Démonter la charnière

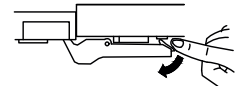
**Warnhinweise****Bestimmungsgemässer Gebrauch:**

Bitte achten Sie darauf, dass Ihre Möbel nur Ihrem Zweck gemäss verwendet werden. Für eine dauerhafte Funktionsfähigkeit ist eine sachgerechte Nutzung und regelmässige Unterhaltungspflege sehr wichtig.

Mises en garde**Utilisation conforme:**

Veillez vous assurer que vos meubles sont utilisés uniquement pour leur usage prévu. Un entretien régulier et une utilisation conforme sont essentiels pour assurer un fonctionnement durable.

Avvertenze**Utilizzo per lo scopo previsto:**

assicuratevi che i vostri mobili siano utilizzati solo per lo scopo per cui sono stati realizzati. Per garantire il loro funzionamento nel tempo è importante utilizzarli correttamente e sottoporli regolarmente a cure manutentive.

Warning notice**Intended use:**

Please make sure that you only use your furniture for the purpose it was designed for. Correct use and regular maintenance are essential for ensuring your furniture remains in working order for the long-term.

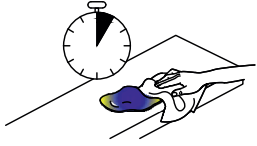
**Reinigung allgemein:**

Flecken immer sofort entfernen. Ein sauberes, weisses Tuch verwenden.



Sauberes Wasser verwenden. Lässt sich der Fleck so nicht entfernen, seifenhaltiges Wasser verwenden. Werden Reinigungsmittel verwendet, diese immer zuerst an einer nicht sichtbaren Stelle testen.



ACHTUNG Keine chemischen, scheuern- oder kratzenden Reinigungs-/Hilfsmittel verwenden.

Nettoyage en général:

Toujours éliminer immédiatement les taches. Utiliser un chiffon blanc, propre.

Utiliser une eau propre. Si la tache ne s'enlève pas, utiliser une eau savonneuse. Si un produit de nettoyage est utilisé, toujours l'essayer préalablement dans un endroit invisible.

ATTENTION Ne pas utiliser de produits ou moyens chimiques, agressifs ou abrasifs.

Pulizia generale:

rimuovere sempre subito le macchie. Utilizzare un panno bianco, pulito.

Utilizzare acqua pulita. Se la macchia non viene via, utilizzare dell'acqua con sapone. Se si utilizzano dei detersivi, provarli sempre prima in un punto non visibile.

ATTENZIONE Non utilizzare detersivi chimici o prodotti/materiali abrasivi.

General cleaning instructions:

Always remove stains immediately. Use a clean, white cloth.

Use clean water. If the stain does not come out, use soapy water. If you use cleaning detergents, always test them first in a concealed spot.

CAUTION Do not use any chemical or abrasive cleaning detergents or cloths/tools.