Wichtig:
Vor Gebrauch sorgfältig durchlesen/
Montageanleitung für
späteres Nachlesen
aufbewahren

Important:
Lisez attentivement/
conserver les instruc-
tions d'installation
pour référence future
avant utilisation

Importante:
lettura/conservare
Istruzioni per l'installa-
zione per riferimento
futuro accuratamente
prima dell'uso

Important:
Read carefully before
assembling/keep and
store Instruction for
reference

RIVERA

Art.403658200000

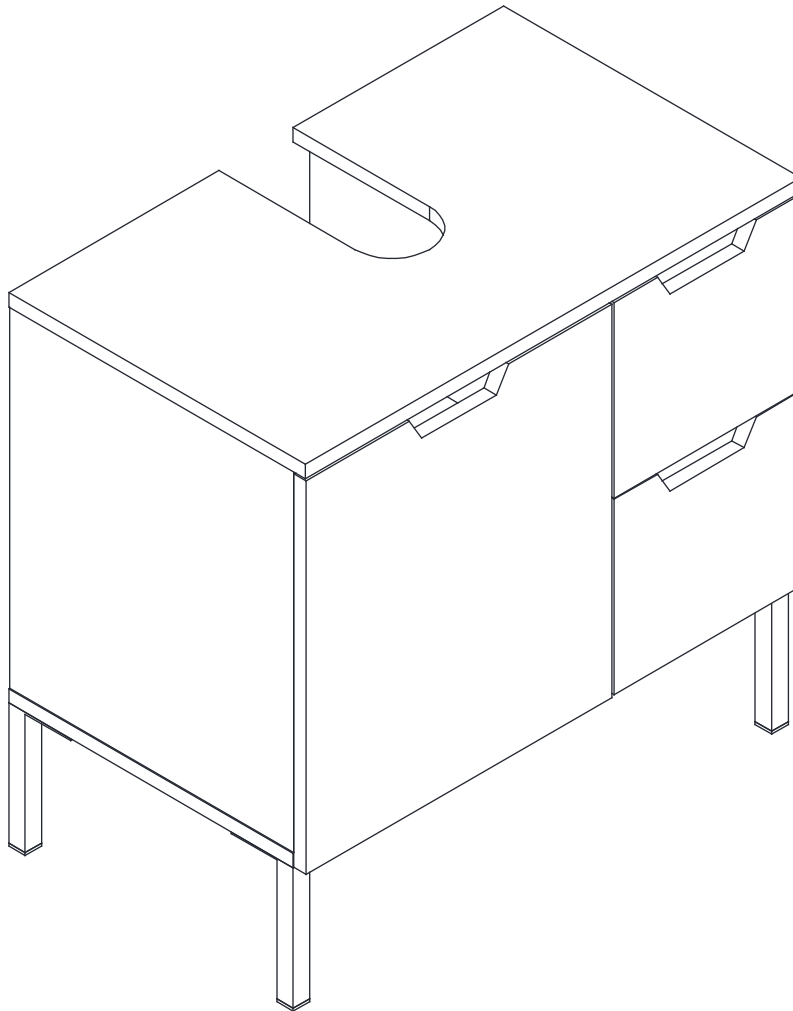



Warnhinweise

Bestimmungsgemässer Gebrauch:

Bitte achten Sie darauf, dass Ihre Möbel nur Ihrem Zweck gemäss verwendet werden. Für eine dauerhafte Funktionsfähigkeit ist eine sachgerechte Nutzung und regelmässige Unterhaltspflege sehr wichtig.

Mises en garde

Utilisation conforme:

Veillez vous assurer que vos meubles sont utilisés uniquement pour leur usage prévu. Un entretien régulier et une utilisation conforme sont essentiels pour assurer un fonctionnement durable.

Avvertenze

Utilizzo per lo scopo previsto:

assicuratevi che i vostri mobili siano utilizzati solo per lo scopo per cui sono stati realizzati. Per garantire il loro funzionamento nel tempo è importante utilizzarli correttamente e sottoporli regolarmente a cure manutentive.

Warning notice

Intended use:

Please make sure that you only use your furniture for the purpose it was designed for. Correct use and regular maintenance are essential for ensuring your furniture remains in working order for the long-term.

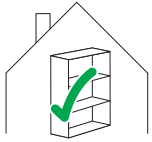

Anwendung:

Das von Ihnen erworbene Behältnismöbel eignet sich für den allgemeinen, privaten Wohnbereich. Es ist nicht für den Nass-, Aussen- oder gewerblichen Bereich geeignet.

Usage:

Le meuble de rangement que vous avez acheté convient pour l'habitat privé en général. Il ne convient pas pour l'extérieur, les milieux humides ou le domaine commercial.

Impiego:

il mobile contenitore acquistato è adatto per un utilizzo in generale, in ambiente domestico. Non è adatto per gli esterni, per l'esposizione alla pioggia o per ambienti commerciali.

Area of use:

The storage furniture you have purchased is suitable for use in general private living quarters. It is not suitable for areas that are wet, outside or used for commercial purposes.

**Warnhinweise****Mises en garde****Avvertenze****Warning notice**

**WARNUNG
Verschluck- und
Erstickungsgefahr:**
Kleinteile und Ver-
packungsmaterial
können verschluckt
werden.

**AVERTISSEMENT
Risque d'ingestion et
d'étouffement:**
Les petites pièces et le
matériel d'emballage
peuvent être avalés.

**AVVERTENZA
Pericolo di ingestione
e soffocamento:**
piccole parti e mate-
riale di imballaggio
possono essere in-
gerite.

**WARNING
Risk of swallowing
and choking:**
Small parts and pack-
aging material may
be swallowed.



WARNUNG! Tüten und
Folien sind kein Spiel-
zeug! Bitte von Babys
und Kleinkindern
fernhalten! Nicht über
den Kopf ziehen;
Erstickungsgefahr!

AVERTISSEMENT! Les
sacs et films ne sont
pas des jouets!
Veuillez les tenir hors
de portée des bébés
et jeunes enfants! Ne
pas mettre sur la tête,
risque d'étouffement!

AVVERTENZA! Sacchet-
ti e pellicole non sono
un giocattolo! Tenere
lontano dalla portata
dei neonati e dei bam-
bini piccoli! Non met-
terli in testa, pericolo di
soffocamento!

WARNING! Bags and
film coverings are
not toys! Please keep
away from babies
and small children! Do
not put them over your
head, risk of suffoca-
tion!



**VORSICHT,
Verletzungsgefahr:**
Kleinkinder dürfen sich
nicht im Montage-Ber-
eich aufhalten und an
Möbeln hochziehen
oder hinaufklettern.

**PRÉCAUTION,
risque de blessures:**
Les jeunes enfants ne
peuvent pas se tenir
dans la zone de mon-
tage ni tirer ou grimper
sur des meubles.

**PRECAUZIONE,
pericolo di lesioni:**
tenere i bambini lonta-
no dal luogo di mon-
taggio e evitare che si
appendano o arram-
pichino sul mobile.

**PRECAUTION,
risk of injury:**
Small children must
keep away from the
assembly area. They
must refrain from
climbing up on the
furniture.







Altersfreigabe:
Nicht für Kinder unter
drei Jahren geeignet.

Age minimum:
Ne convient pour les
enfants de moins de
trois ans.

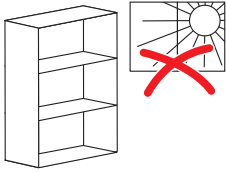
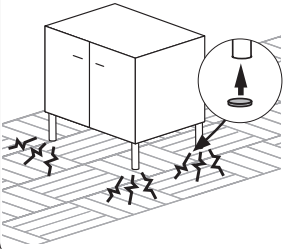
Limite di età:
non adatto per bambi-
ni sotto i tre anni.

Age restriction:
Not suitable for chil-
dren under three.

1.	Allgemeine Hinweise	Remarques générales	Avvertenze generali	General information
	<p>ACHTUNG Direkte Sonneneinstrahlung: Führt zu Farbveränderungen.</p>	<p>ATTENTION Exposition directe au soleil: Provoque des décolorations.</p>	<p>ATTENZIONE Irraggiamento diretto del sole: ne modifica il colore.</p>	<p>ATTENTION Direct sunlight: results in discolouration.</p>
	<p>Schutzgleiter: Mit Schutzgleitern (z.B. aus Filz), lassen sich Schäden auf kratzempfindlichen Böden (z.B. Parkett) vermeiden.</p>	<p>Patins: Les patins (p.ex. en feutre) permettent d'éviter d'endommager les sols sensibles aux rayures (p.ex. parquet).</p>	<p>Scivolante protettivo: grazie agli scivolanti protettivi (ad es. feltro) si evita di danneggiare pavimenti sensibili ai graffi (ad es. parquet).</p>	<p>Protective covers: Protective covers, e.g. felt pads, prevent damage to floors that are easily scratched (e.g. parquet).</p>
	<p>ACHTUNG, Temperatur: Nie heiße oder sehr kalte Objekte direkt auf die Oberfläche stellen. Geeigneten Schutz verwenden, z.B. Untersteller.</p>	<p>ATTENTION, température: Ne jamais poser des objets chauds ou très froids directement sur la surface. Utiliser une protection appropriée, p.ex. sous-plat.</p>	<p>ATTENZIONE, temperatura: non appoggiare mai oggetti caldi o molto freddi direttamente sulla superficie. Utilizzare una protezione adatta, ad es. un sotto piatto.</p>	<p>ATTENTION, temperature: Do not place hot or cold objects directly on the surface. Use the appropriate protection, e.g. saucer.</p>
2.	Montagehinweise	Instructions de montage	Istruzioni di montaggio	Assembly information
	<p>Montageschäden: Vermeiden Sie, indem Sie einen sauberen und weichen Untergrund verwenden (z.B. Teppich). Teile beim Auspacken oder während der Montage nur auf weiche Unterlagen legen/stellen. Darauf achten, dass grössere Teile nicht kippen können.</p>	<p>Dommages au montage: Évitez les dommages en utilisant un fond propre et doux (p.ex. tapis). Lors du déballage et montage, posez/placez les éléments uniquement sur un fond doux. Assurez-vous que les grands éléments ne peuvent pas basculer.</p>	<p>Danni in fase di montaggio: evitare di causare danni utilizzando una base pulita e morbida (ad es. tappeto). Nella fase di disimballaggio e durante il montaggio, appoggiare i pezzi esclusivamente su una base morbida. Fare attenzione che i pezzi più grandi non si ribaltino.</p>	<p>Damages during assembly: These can be avoided if you use a clean soft surface (e.g. carpet). Only place parts on a soft surface when unpacking or during the assembly. Make sure that larger parts cannot tip over.</p>
	<p>Personen: Für die Montage erforderliche Anzahl Personen.</p>	<p>Personnes: Nombre de personnes nécessaires au montage.</p>	<p>Persone: numero di persone necessarie per il montaggio.</p>	<p>People: Number of people required for the assembly.</p>

2.

**Montage-
hinweise**

**Instructions de
montage**

**Istruzioni di
montaggio**

**Assembly
information**



Montagerichtzeit:

Ungefähre Zeit in
Stunden.

**Durée indicative du
montage:**

Durée approximative
en heures.

Tempo di montaggio:

tempo in ore approssi-
mativo.

Assembly time:

Approximate time in
hours.

Benötigtes Werkzeug:

Outils nécessaires:

Attrezzi necessari:

Tools required:

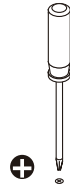
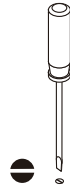

Bau-/Kleinteile:

Éléments/pièces:

**Componenti/
piccoli pezzi:**

**Components/
small parts:**

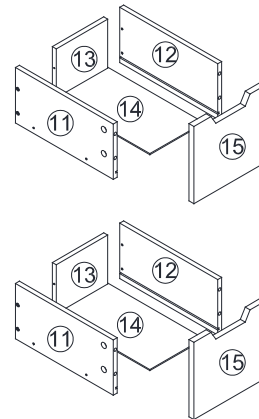
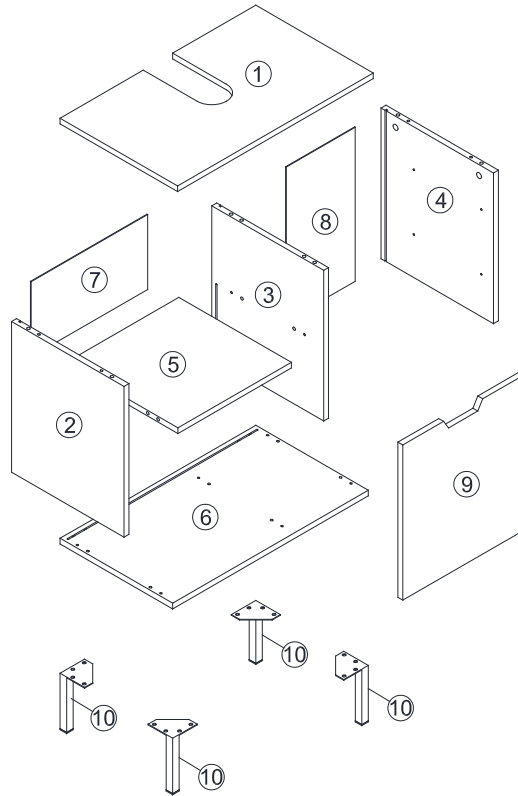

Bau-/Kleinteile:

Éléments/pièces:

**Componenti/
piccoli pezzi:**

**Components/
small parts:**



A x18



Ø15x10mm
B x18



8x30mm
C x16



4x35mm
D x6



4x25mm
E x8



F x2



G x2



3x12mm
H x16



6x14mm
I x16



J x2



4x14mm
K x12



L x1



M x8



3x14mm
N x8

3.

Montage-
anleitung

Instructions de
montage

Istruzioni per
il montaggio

Assembling
instruction

1

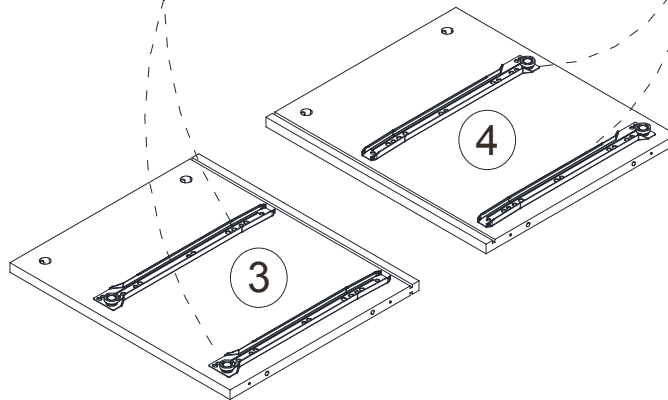
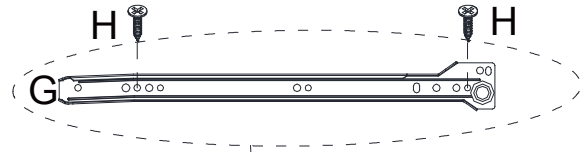
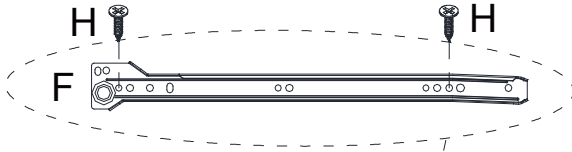

2

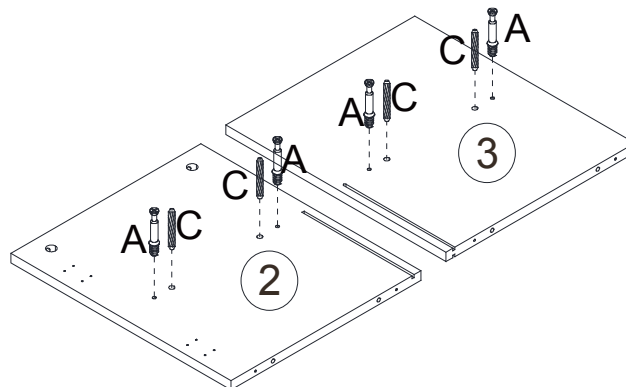
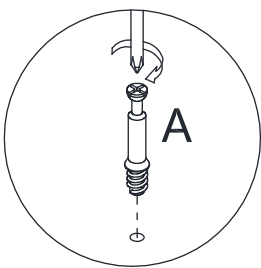

3

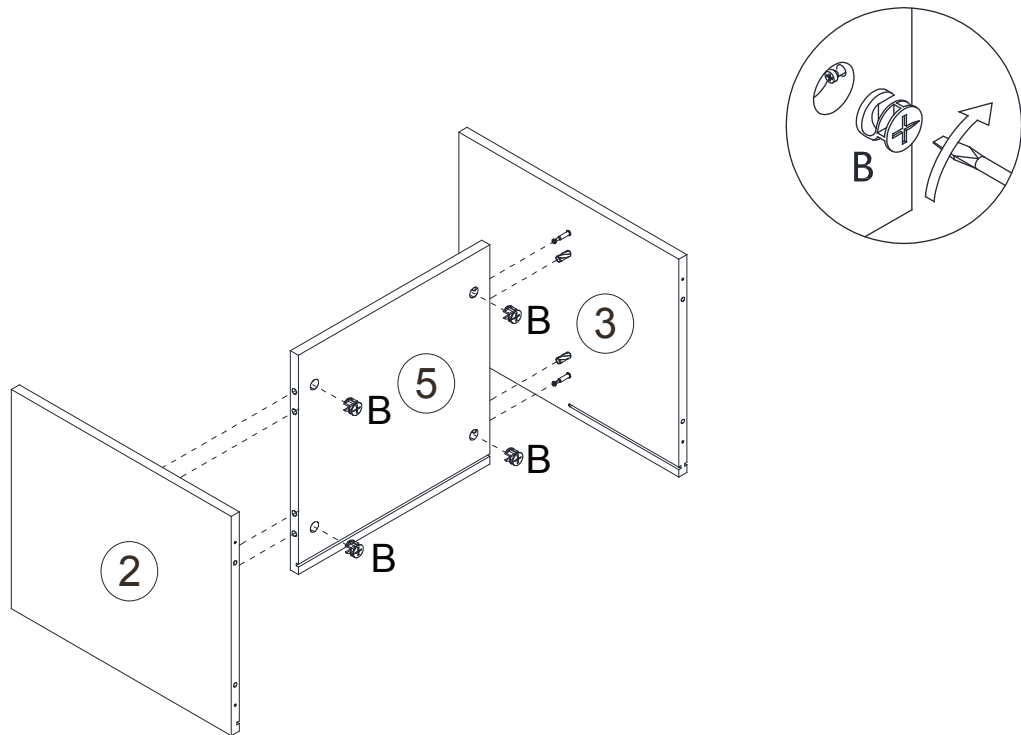

4

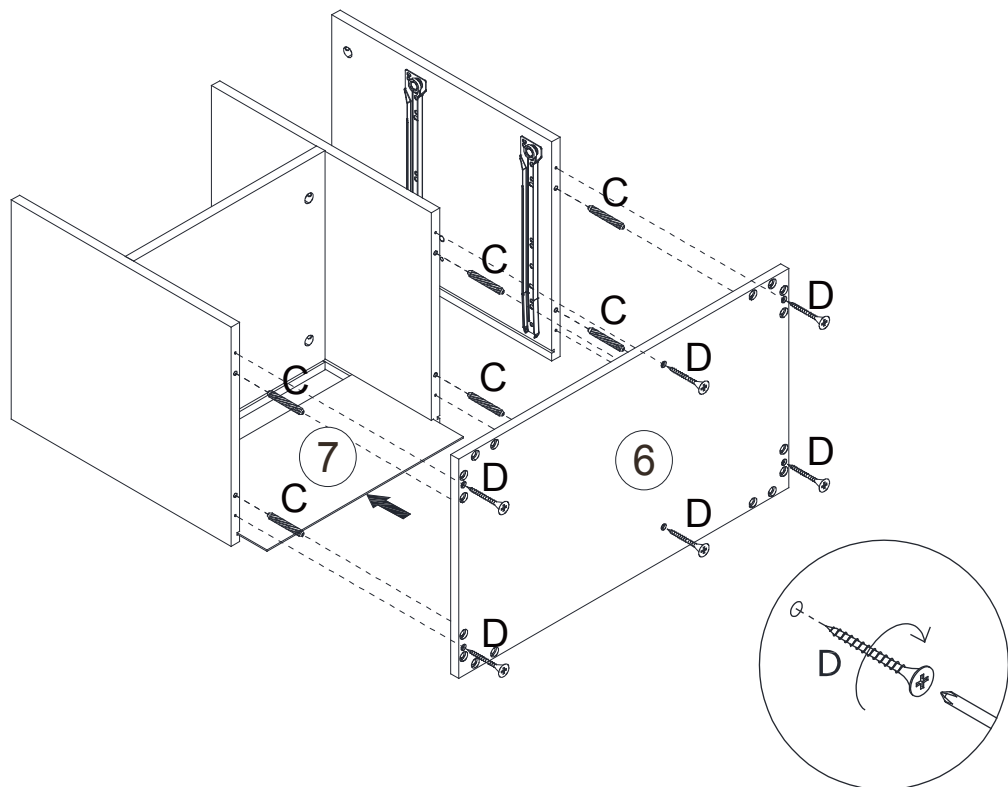

5

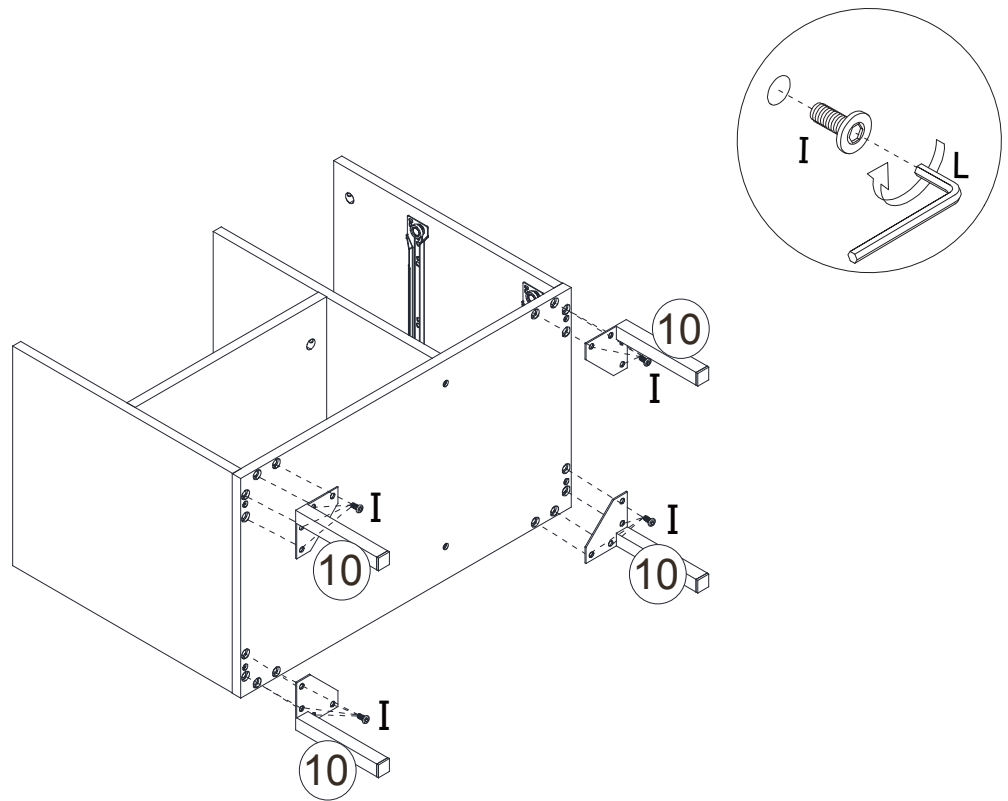

6

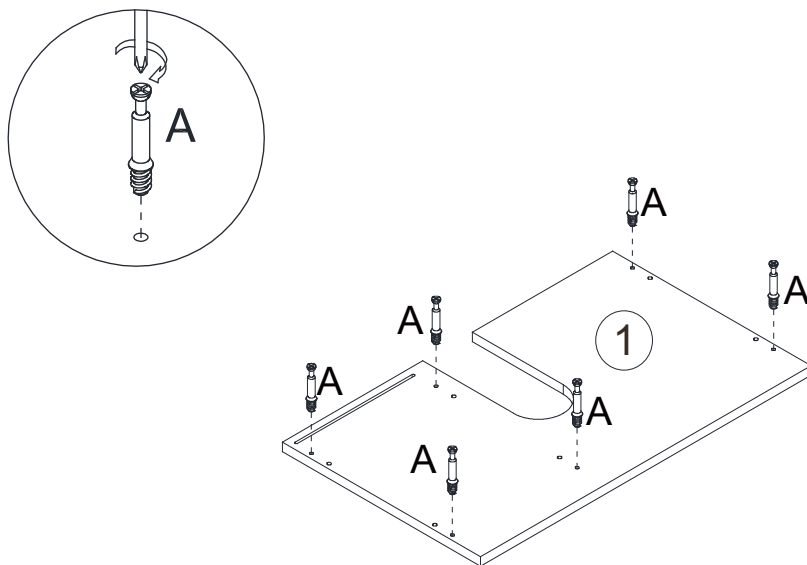

Montage-
anleitung

Instructions de
montage

Istruzioni per
il montaggio

Assembling
instruction

7

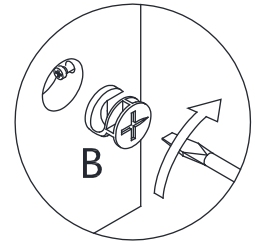
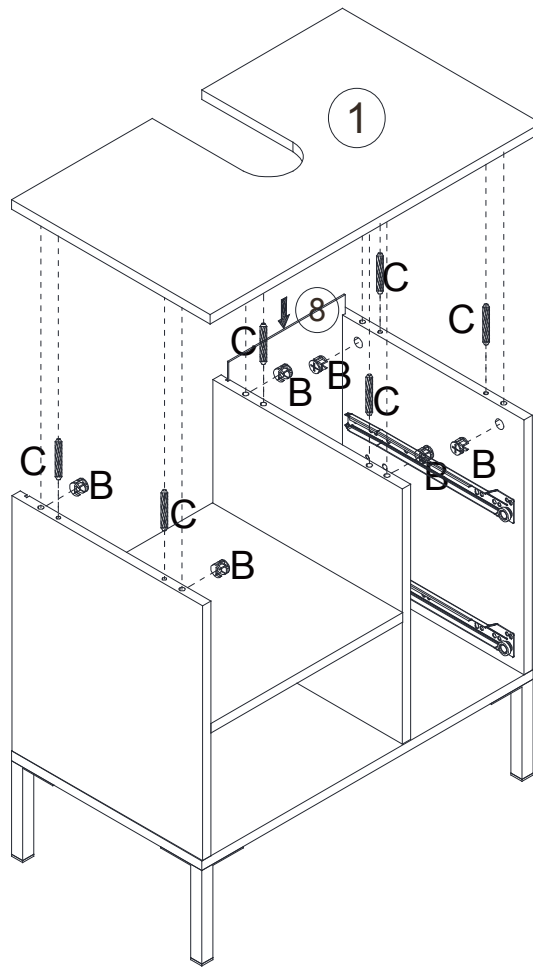

8

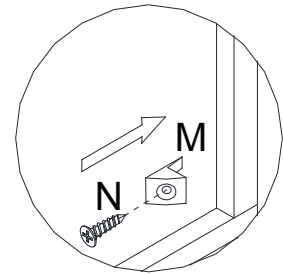
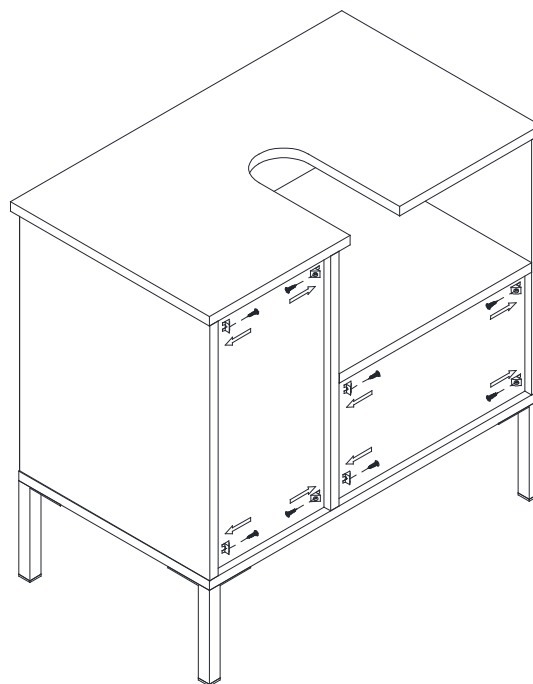
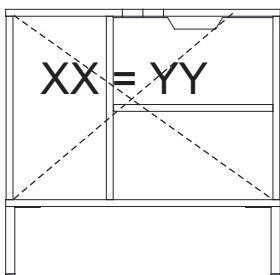

9



x2

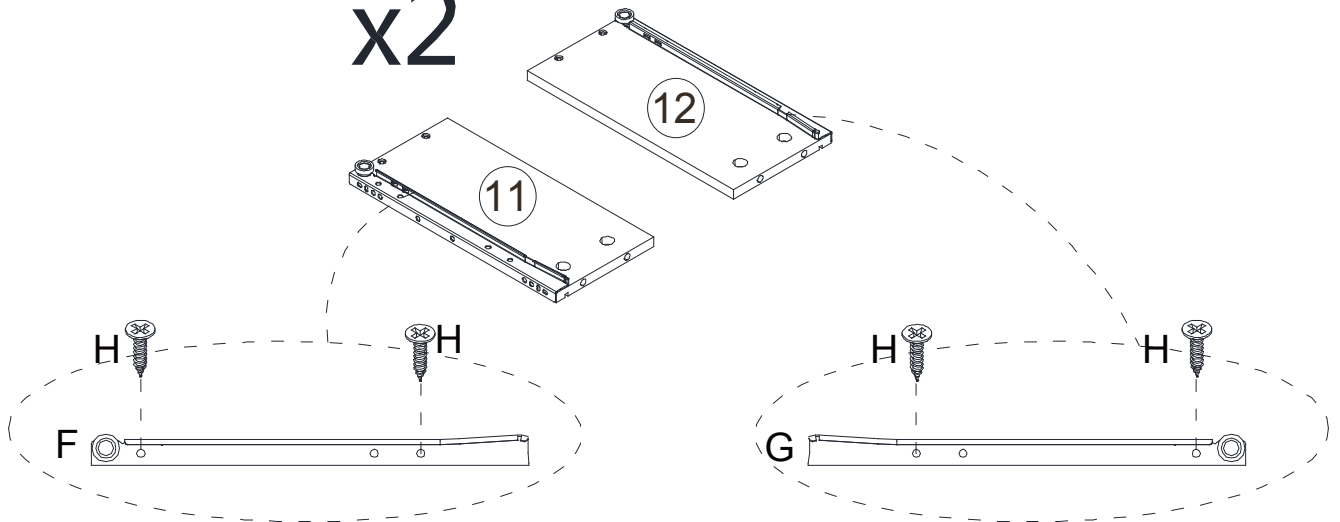

10

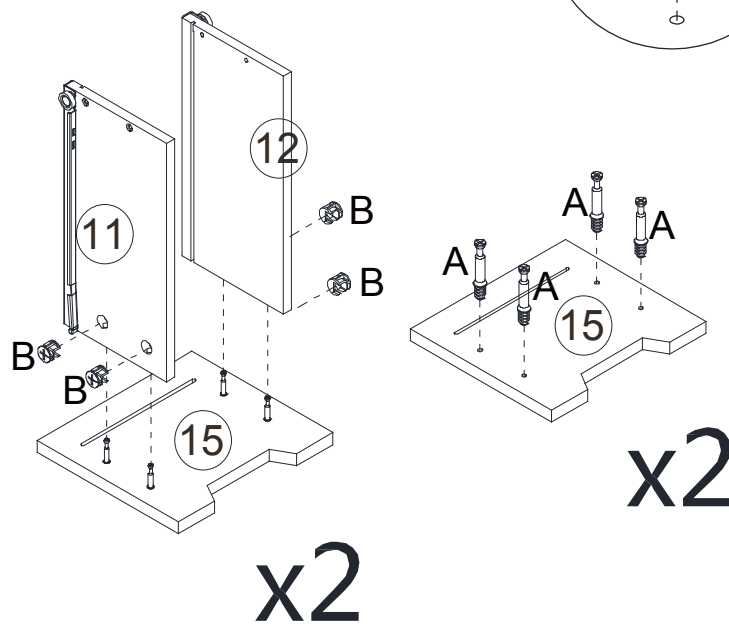
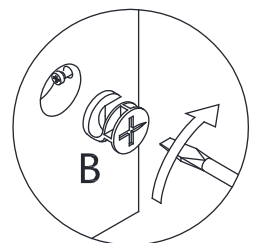
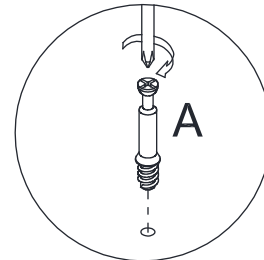

11

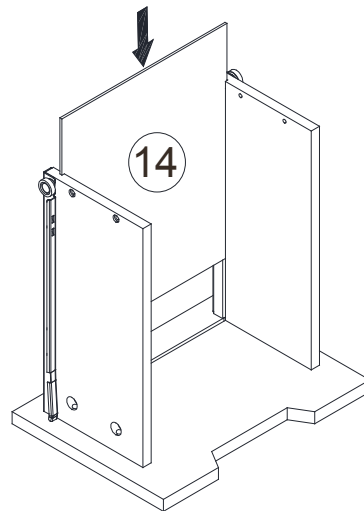

x2

12

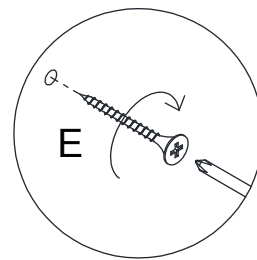
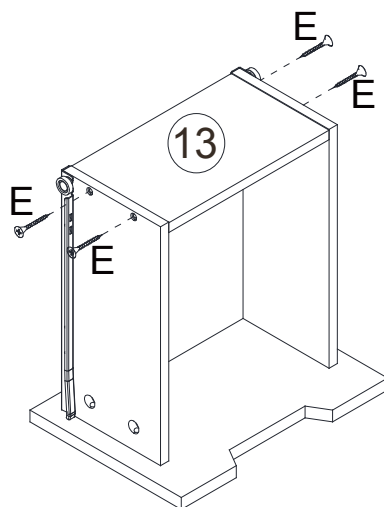

x2

13

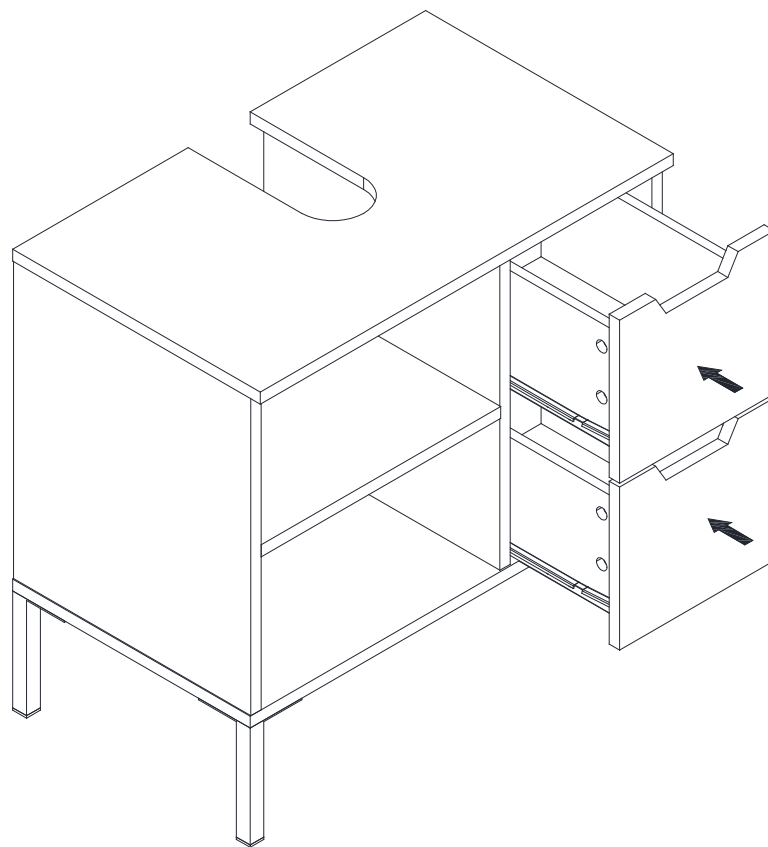

14

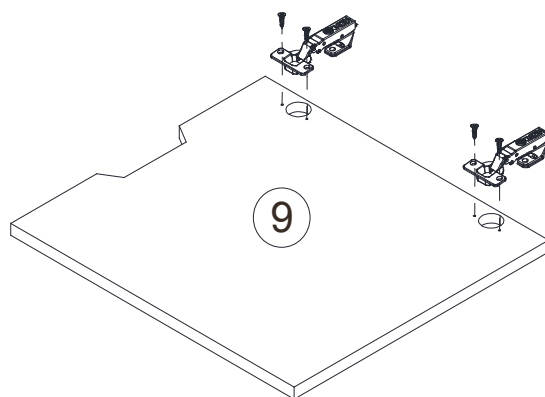
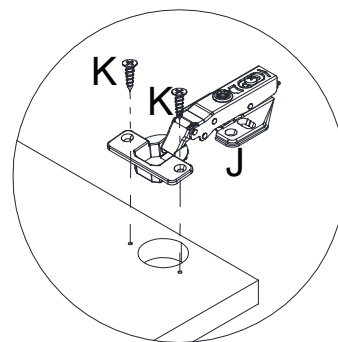

Montage-
anleitung

Instructions de
montage

Istruzioni per
il montaggio

Assembling
instruction

15

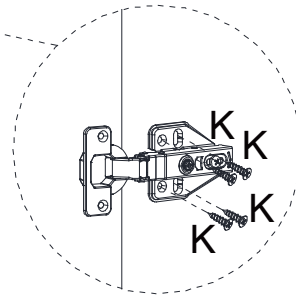
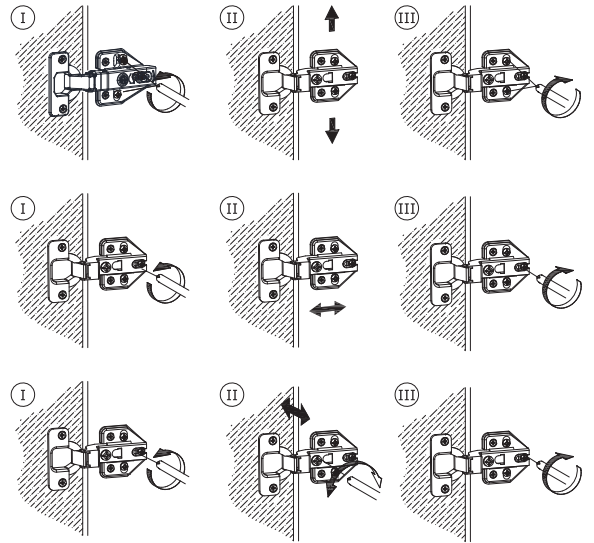
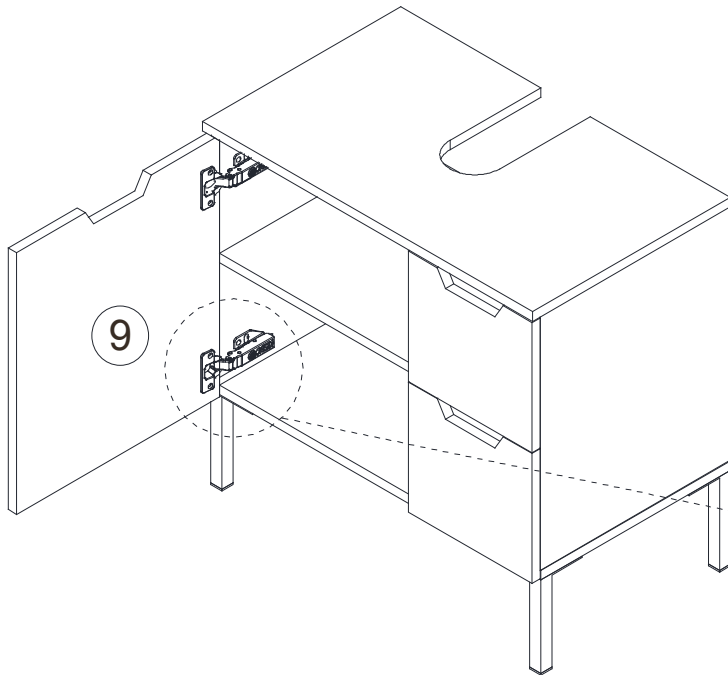

16

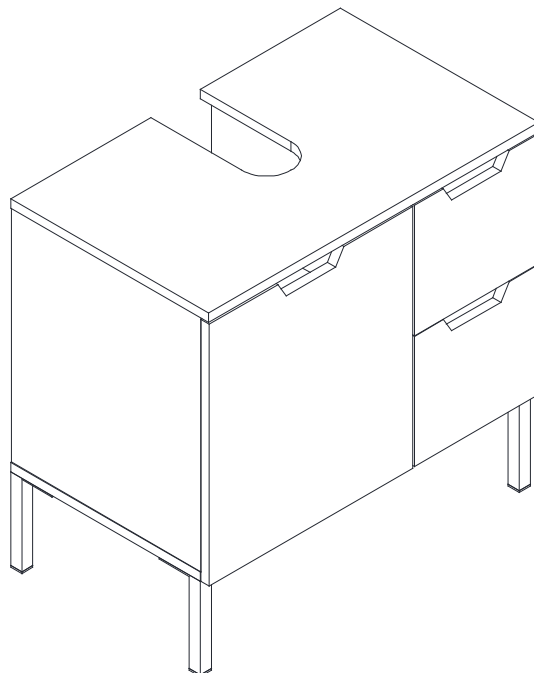

4.

Pflege

Soin

Cura

Care

**Reinigung allgemein:**

Flecken immer sofort entfernen. Ein sauberes, weisses Tuch verwenden.



Sauberes Wasser verwenden. Lässt sich der Fleck so nicht entfernen, seifenhaltiges Wasser verwenden. Werden Reinigungsmittel verwendet, diese immer zuerst an einer nicht sichtbaren Stelle testen.



ACHTUNG Keine chemischen, scheuern- oder kratzenden Reinigungs-/Hilfsmittel verwenden.

Nettoyage en général:

Toujours éliminer immédiatement les taches. Utiliser un chiffon blanc, propre.

Utiliser une eau propre. Si la tache ne s'enlève pas, utiliser une eau savonneuse. Si un produit de nettoyage est utilisé, toujours l'essayer préalablement dans un endroit invisible.

ATTENTION Ne pas utiliser de produits ou moyens chimiques, agressifs ou abrasifs.

Pulizia generale:

rimuovere sempre subito le macchie. Utilizzare un panno bianco, pulito.

Utilizzare acqua pulita. Se la macchia non viene via, utilizzare dell'acqua con sapone. Se si utilizzano dei detergenti, provarli sempre prima in un punto non visibile.

ATTENZIONE Non utilizzare detergenti chimici o prodotti/materiali abrasivi.

General cleaning instructions:

Always remove stains immediately. Use a clean, white cloth.

Use clean water. If the stain does not come out, use soapy water. If you use cleaning detergents, always test them first in a concealed spot.

CAUTION Do not use any chemical or abrasive cleaning detergents or cloths/tools.

5.

Wartung

Entretien

Manutenzione

Maintenance

**Schrauben:**

Für einwandfreie, zuverlässige Funktion, Schrauben regelmäßig nachziehen (z.B. halbjährlich).

Vis:

Resserrer régulièrement les vis (p.ex. tous les 6 mois) pour assurer un fonctionnement sûr et correct.

Viti:

per garantire un funzionamento corretto e sicuro tirare regolarmente le viti (ad es. ogni sei mesi).

Screws:

To keep your furniture in good working order, tighten the screws regularly (e.g. every six months).

6.

Entsorgung**Élimination****Smaltimento****Disposal**

Entsorgungsservice:

Micasa bietet Ihnen einen Entsorgungsservice an. Weitere Informationen erhalten Sie unter

www.micasa.ch

Entsorgung:

Nicht mehr verwendete Möbel der fachgerechten Entsorgung übergeben. Wenden Sie sich an Ihre lokale Entsorgungsstelle.

Service d'élimination:

Micasa vous propose un service d'élimination. Vous trouverez des informations supplémentaires sur

www.micasa.ch

Élimination:

Veillez remettre les meubles qui ne sont plus utilisés à une entreprise d'élimination. Adressez-vous à votre centre de collecte local.

Servizio di smaltimento:

Micasa vi offre un servizio di smaltimento. Ulteriori informazioni sono disponibili su

www.micasa.ch

Smaltimento:

i mobili dismessi devono essere conferiti presso i centri di raccolta rifiuti per il loro corretto smaltimento. Rivolgersi presso il centro di raccolta locale.

Disposal service:

Micasa offers a disposal service. For more information visit

www.micasa.ch

Disposal:

To correctly dispose of furniture that is no longer used, contact your local recycling centre.

7.

Kontakt / Service**Contact / service****Contatto / servizio****Contact / service**

Fragen /

Anregungen:

Wir sind gerne für Sie erreichbar:

Montag bis Freitag

08.00 bis 18.00 Uhr

Samstag

08.30 bis 16.30 Uhr

Tel. 0800 840 848

Questions / suggestions:

Nous sommes à votre disposition:

Lundi - vendredi

08h00 à 18h00

Samedi

08h30 à 16h30

Tél. 0800 840 848

Domande / suggerimenti:

siamo a vostra disposizione:

lunedì - venerdì

dalle 08.00 alle 18.00

sabato

dalle 08.30 alle 16.30

Tel. 0800 840 848

Questions / Suggestions

Please contact us. Our opening times are:

Monday - Friday

8.00 to 18.00

Saturday

8.30 to 16.30

Phone 0800 840 848



Ersatzteile:

Erhalten Sie direkt im Online-Shop von

Migros-Service:

www.migros-service.ch

Pièces de rechange:

Vous les obtenez directement dans le

magasin en ligne de

Migros-Service:

www.migros-service.ch

Pezzi di ricambio:

sono disponibili direttamente

sull'online-shop di

Migros-Service:

www.migros-service.ch

Spare parts:

Available directly from the Migros-Service

online shop:

www.migros-service.ch