

Vincente



Wichtig:
Vor Gebrauch sorgfältig
durchlesen/
Montageanleitung für
späteres Nachlesen
aufbewahren

Importante:
Lettura/conservare
Istruzioni per l'installazione
per riferimento
futuro accuratamente
prima dell'uso

Important:
Lisez attentivement/
conserver les instructions
d'installation pour
référence future avant
utilisation

Important:
Read carefully before
assembling/keep and
store Instruction for
reference

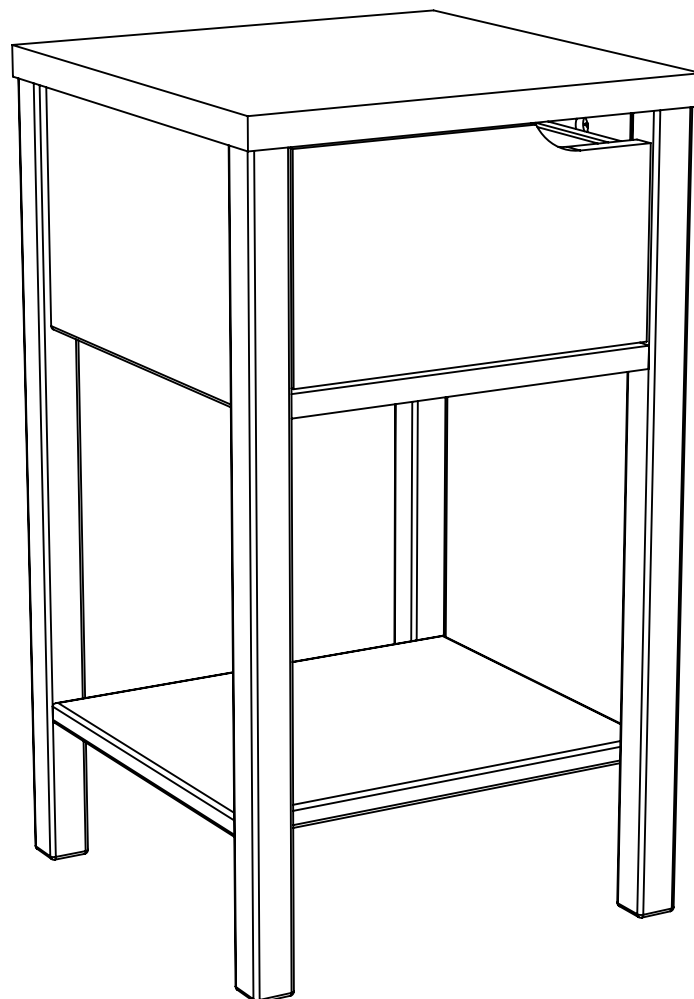
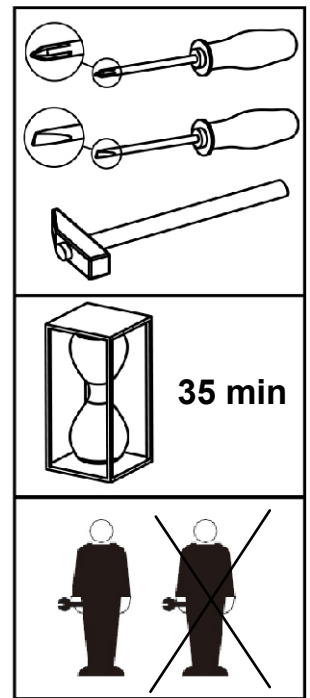



Warnhinweise

Bestimmungsgemässer Gebrauch:

Bitte achten Sie darauf, dass Ihre Möbel nur Ihrem Zweck gemäss verwendet werden. Für eine dauerhafte Funktionsfähigkeit ist eine sachgerechte Nutzung und regelmässige Unterhaltspflege sehr wichtig.

Mises en garde

Utilisation conforme:

Veillez vous assurer que vos meubles sont utilisés uniquement pour leur usage prévu. Un entretien régulier et une utilisation conforme sont essentiels pour assurer un fonctionnement durable.

Avvertenze

Utilizzo per lo scopo previsto:

assicuratevi che i vostri mobili siano utilizzati solo per lo scopo per cui sono stati realizzati. Per garantire il loro funzionamento nel tempo è importante utilizzarli correttamente e sottoporli regolarmente a cure manutentive.

Warning notice

Intended use:

Please make sure that you only use your furniture for the purpose it was designed for. Correct use and regular maintenance are essential for ensuring your furniture remains in working order for the long-term.

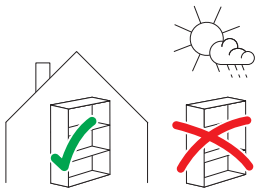

Anwendung:

Das von Ihnen erworbene Behältnismöbel eignet sich für den allgemeinen, privaten Wohnbereich. Es ist nicht für den Nass-, Aussen- oder gewerblichen Bereich geeignet.

Usage:

Le meuble de rangement que vous avez acheté convient pour l'habitat privé en général. Il ne convient pas pour l'extérieur, les milieux humides ou le domaine commercial.

Impiego:

il mobile contenitore acquistato è adatto per un utilizzo in generale, in ambiente domestico. Non è adatto per gli esterni, per l'esposizione alla pioggia o per ambienti commerciali.

Area of use:

The storage furniture you have purchased is suitable for use in general private living quarters. It is not suitable for areas that are wet, outside or used for commercial purposes.



WARNUNG Verschluck- und Erstickungsgefahr:

Kleinteile und Verpackungsmaterial können verschluckt werden.

AVERTISSEMENT Risque d'ingestion et d'étouffement:

Les petites pièces et le matériel d'emballage peuvent être avalés.

AVVERTENZA Pericolo di ingestione e soffocamento:

piccole parti e materiale di imballaggio possono essere ingerite.

WARNING Risk of swallowing and choking:

Small parts and packaging material may be swallowed.



WARNUNG! Tüten und Folien sind kein Spielzeug! Bitte von Babys und Kleinkindern fernhalten! Nicht über den Kopf ziehen; Erstickungsgefahr!

AVERTISSEMENT! Les sacs et films ne sont pas des jouets! Veuillez les tenir hors de portée des bébés et jeunes enfants! Ne pas mettre sur la tête, risque d'étouffement!

AVVERTENZA! Sacchetti e pellicole non sono un giocattolo! Tenere lontano dalla portata dei neonati e dei bambini piccoli! Non metterli in testa, pericolo di soffocamento!

WARNING! Bags and film coverings are not toys! Please keep away from babies and small children! Do not put them over your head, risk of suffocation!

Allgemeine Hinweise

Remarques générales

Avvertenze generali

General information

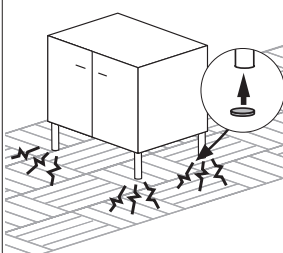

Schutzgleiter:

Mit Schutzgleitern (z.B. aus Filz), lassen sich Schäden auf kratzempfindlichen Böden (z.B. Parkett) vermeiden.

Patins:

Les patins (p.ex. en feutre) permettent d'éviter d'endommager les sols sensibles aux rayures (p.ex. parquet).

Scivolante protettivo:

grazie agli scivolanti protettivi (ad es. feltro) si evita di danneggiare pavimenti sensibili ai graffi (ad es. parquet).

Protective covers:

Protective covers, e.g. felt pads, prevent damage to floors that are easily scratched (e.g. parquet).

Kleinteile:

Pièces:

Piccoli pezzi:

Small parts:

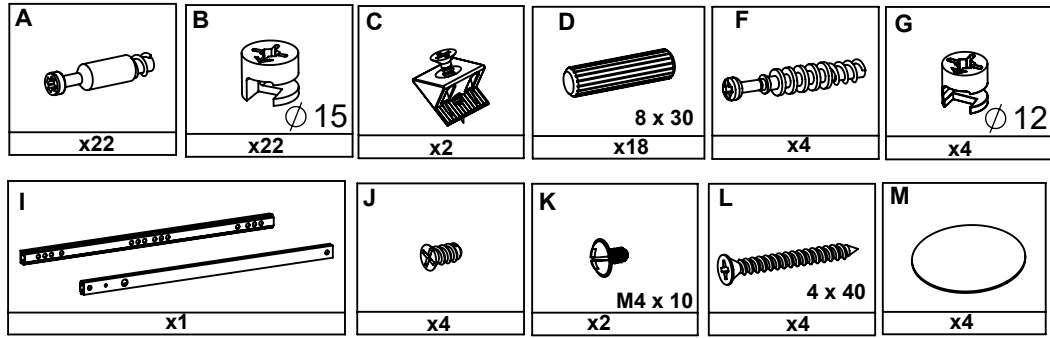

Bauteile:

Éléments:

Componenti:

Components:

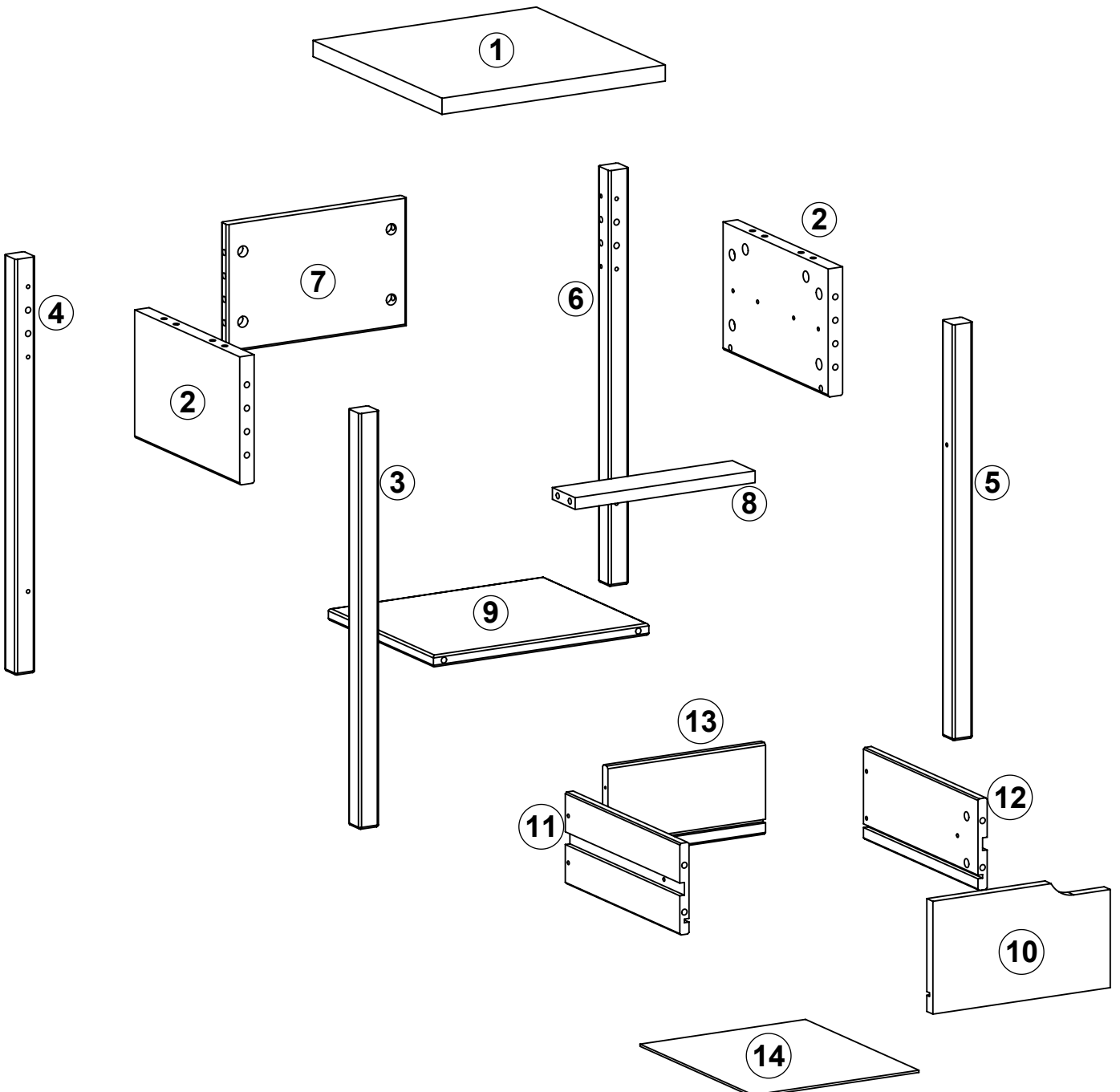

1

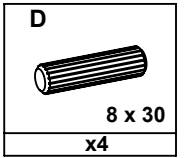
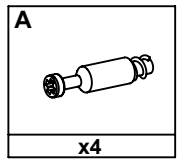
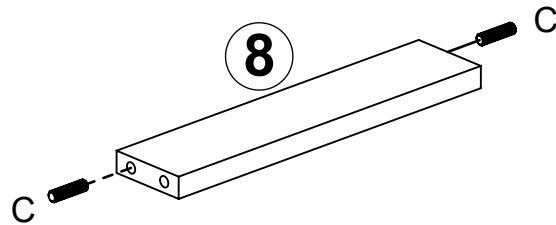
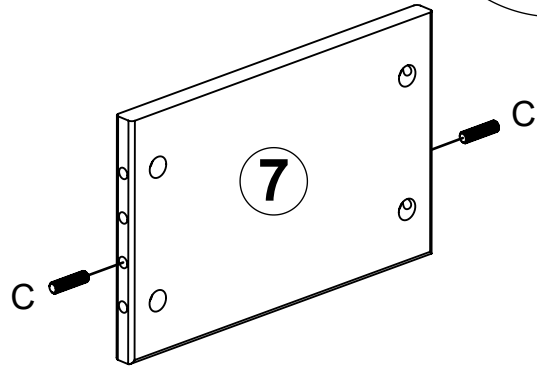
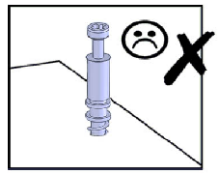
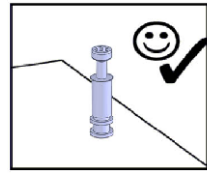
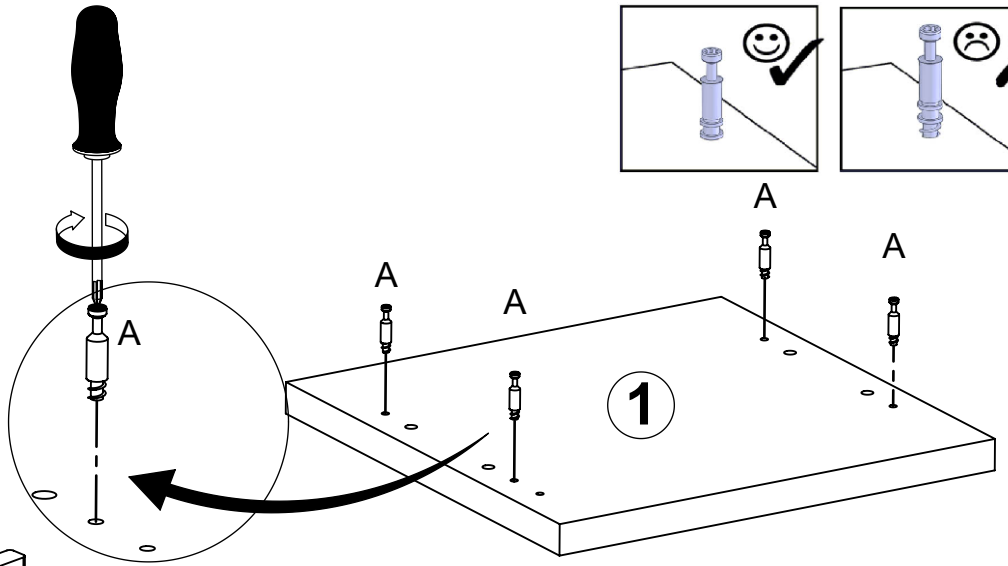
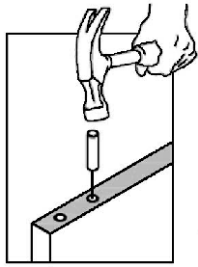

2

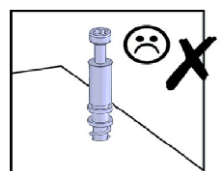
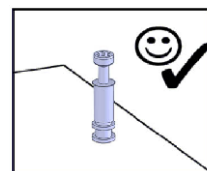
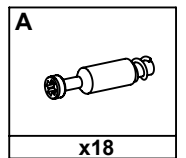
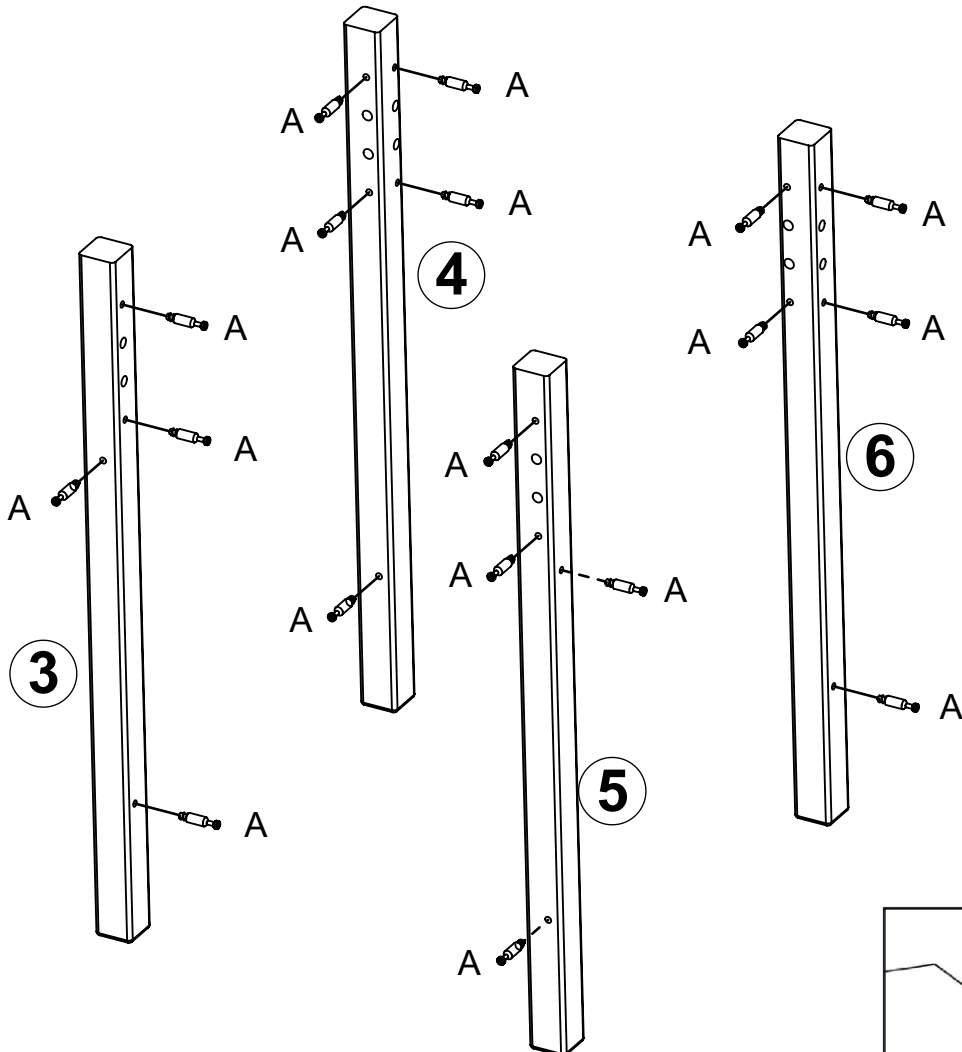

3

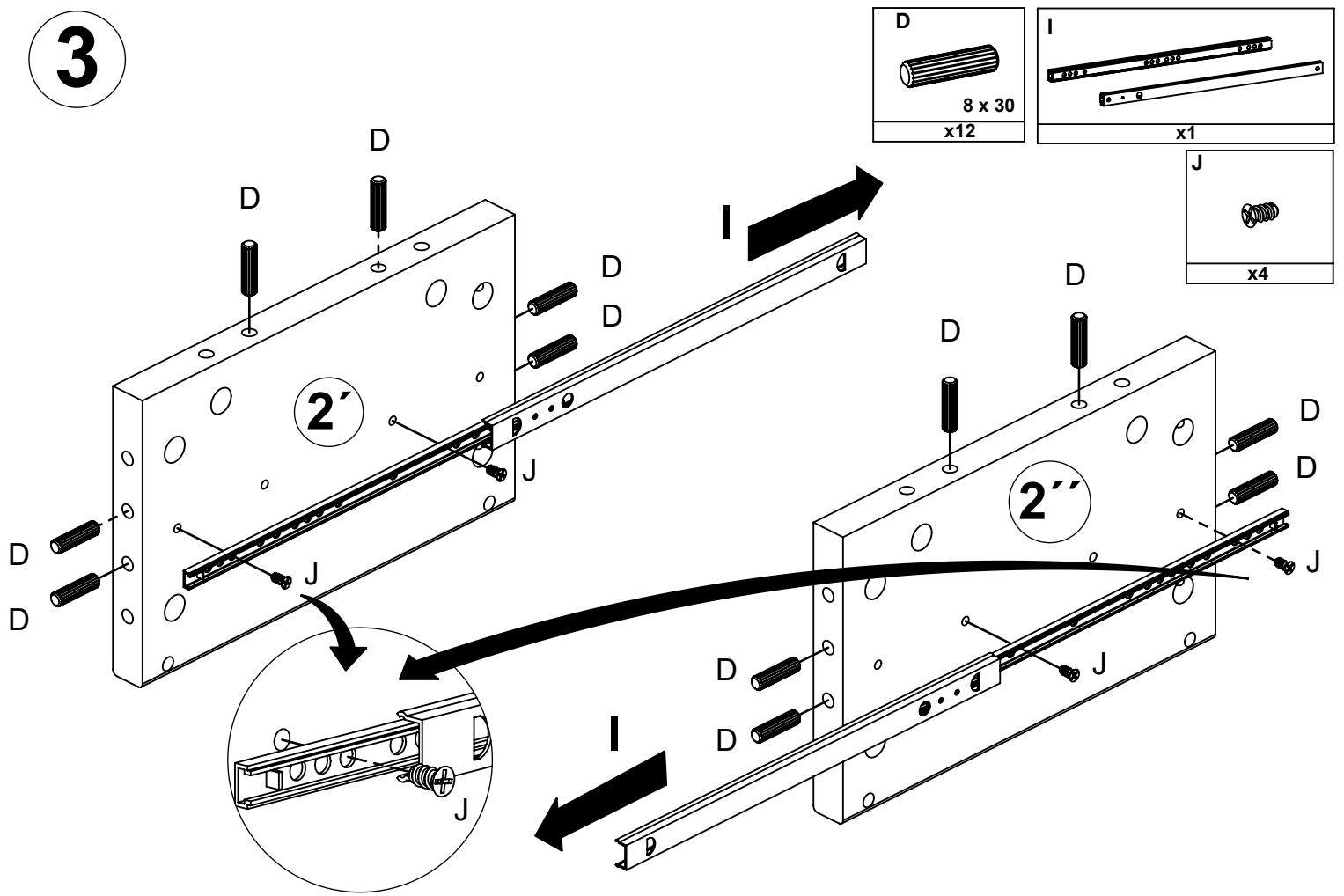

4

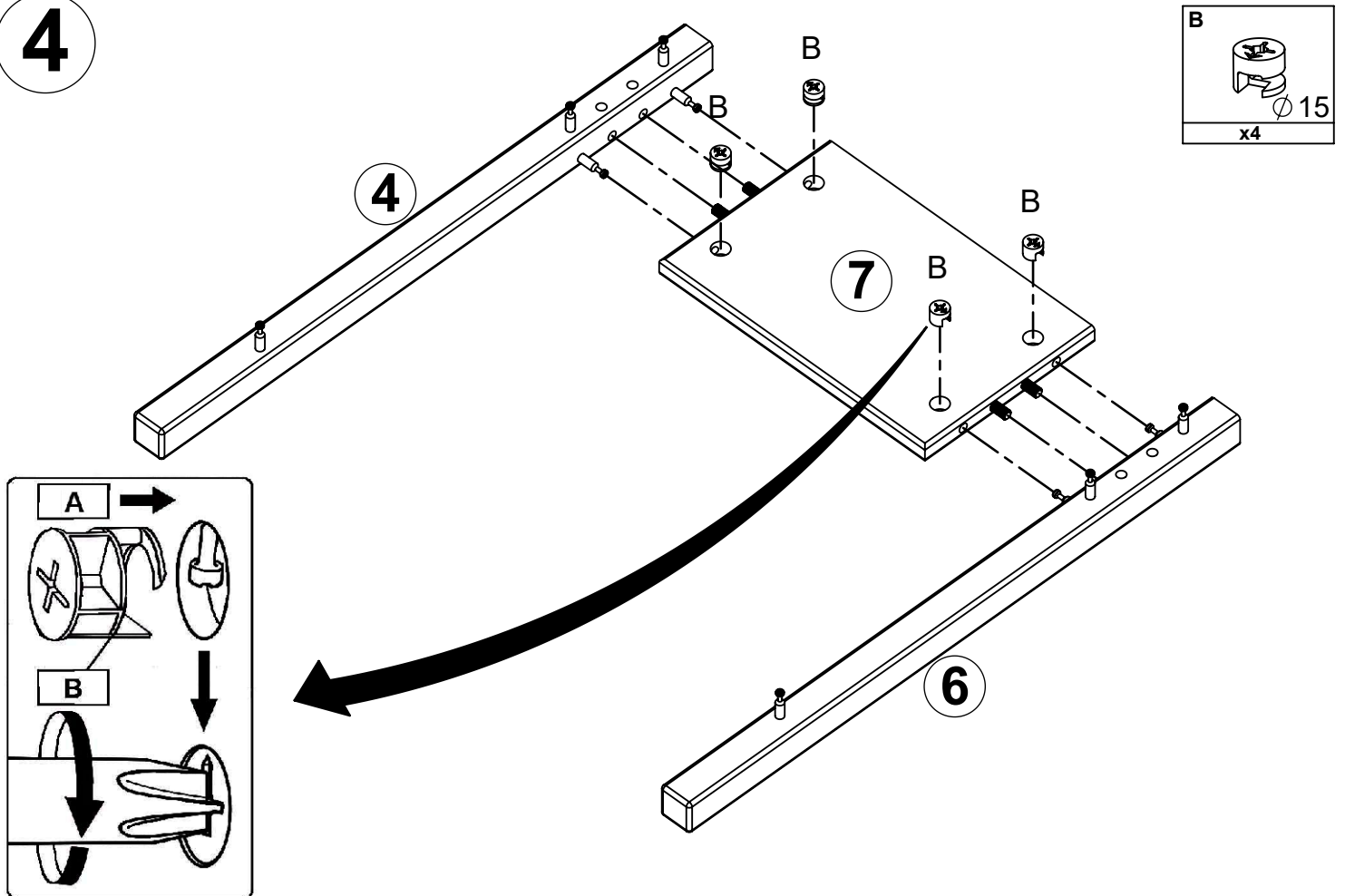

5

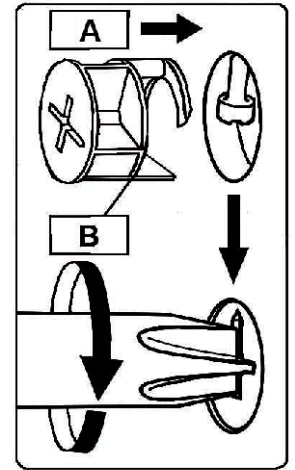
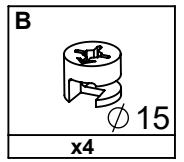
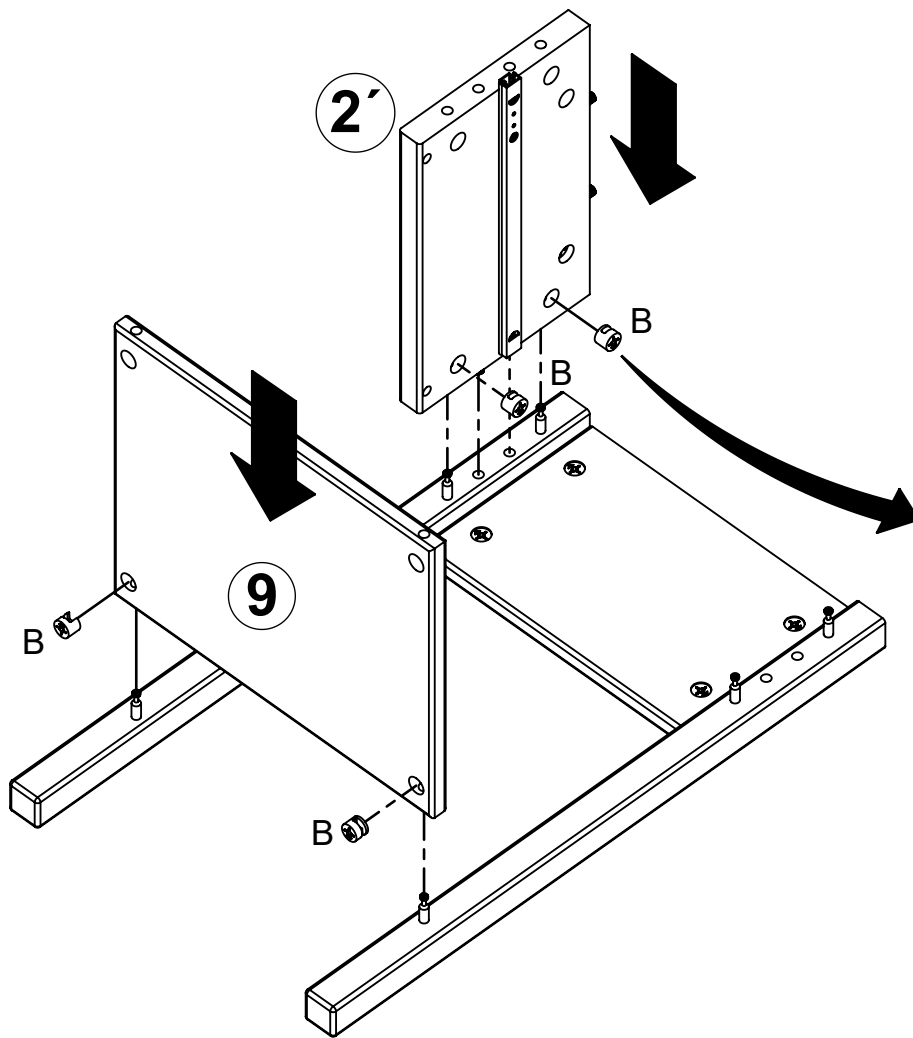

6

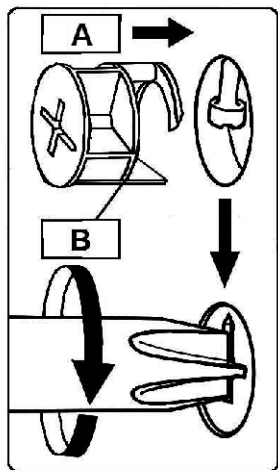
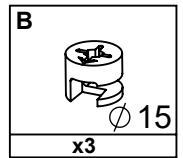
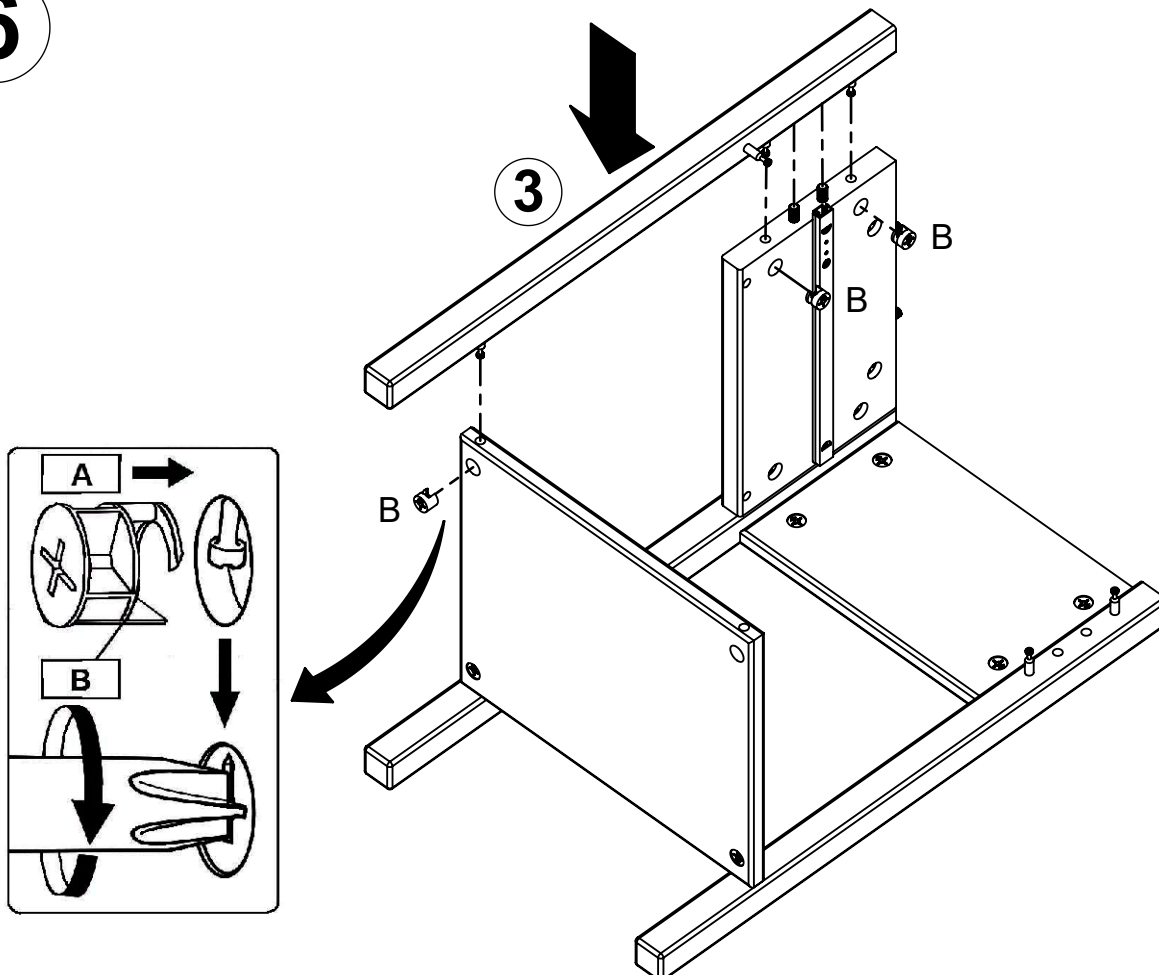

7

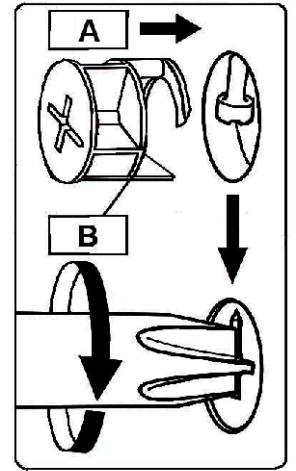
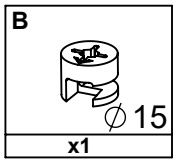
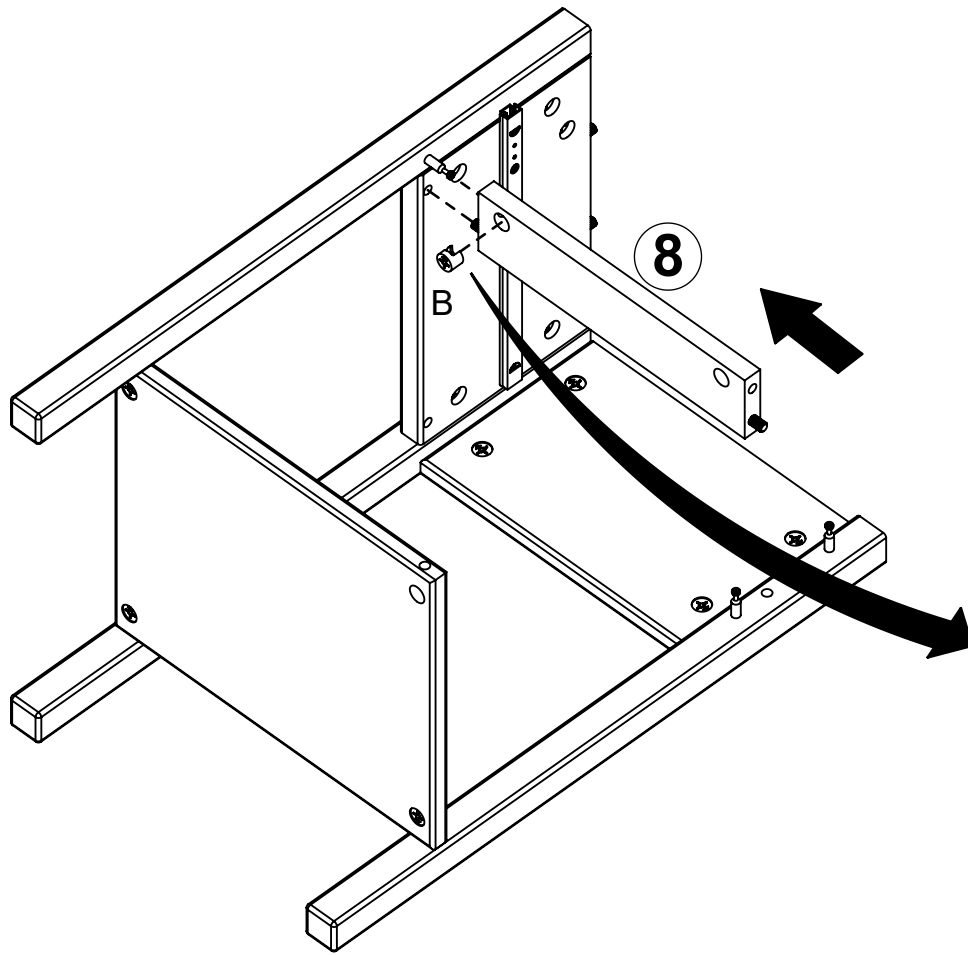

8

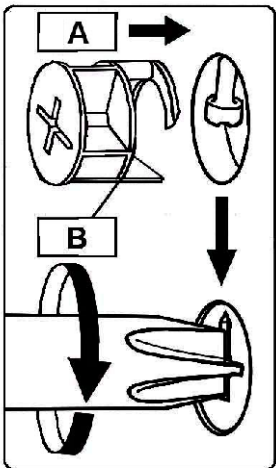
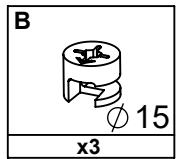
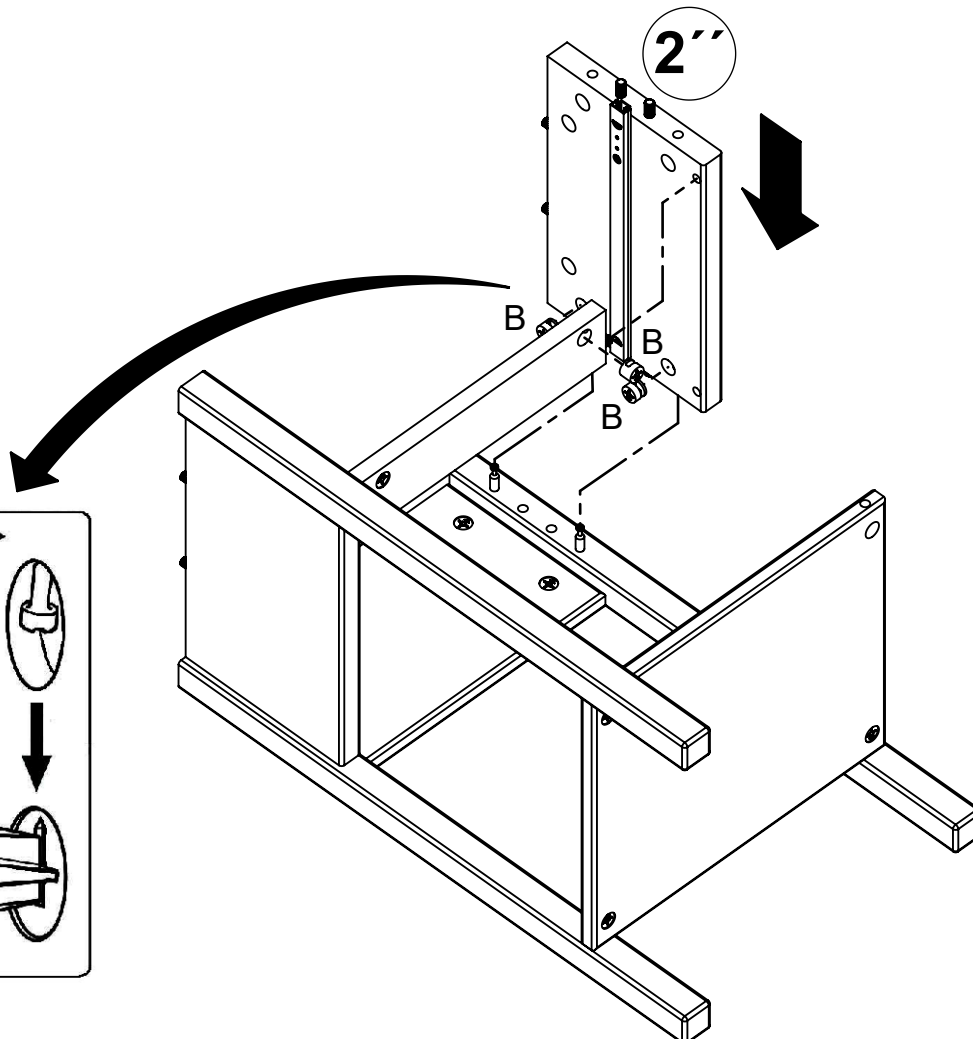

9

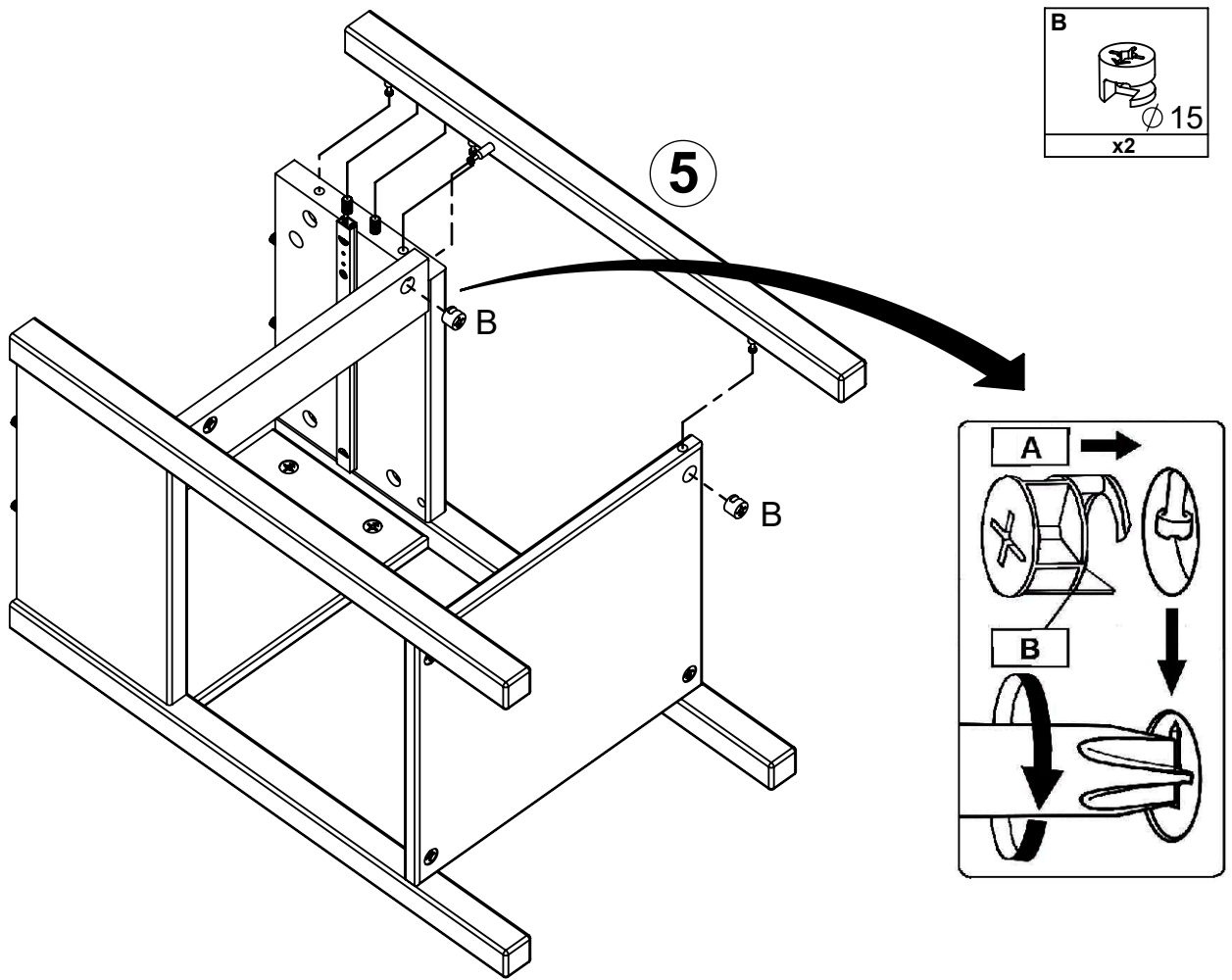

10

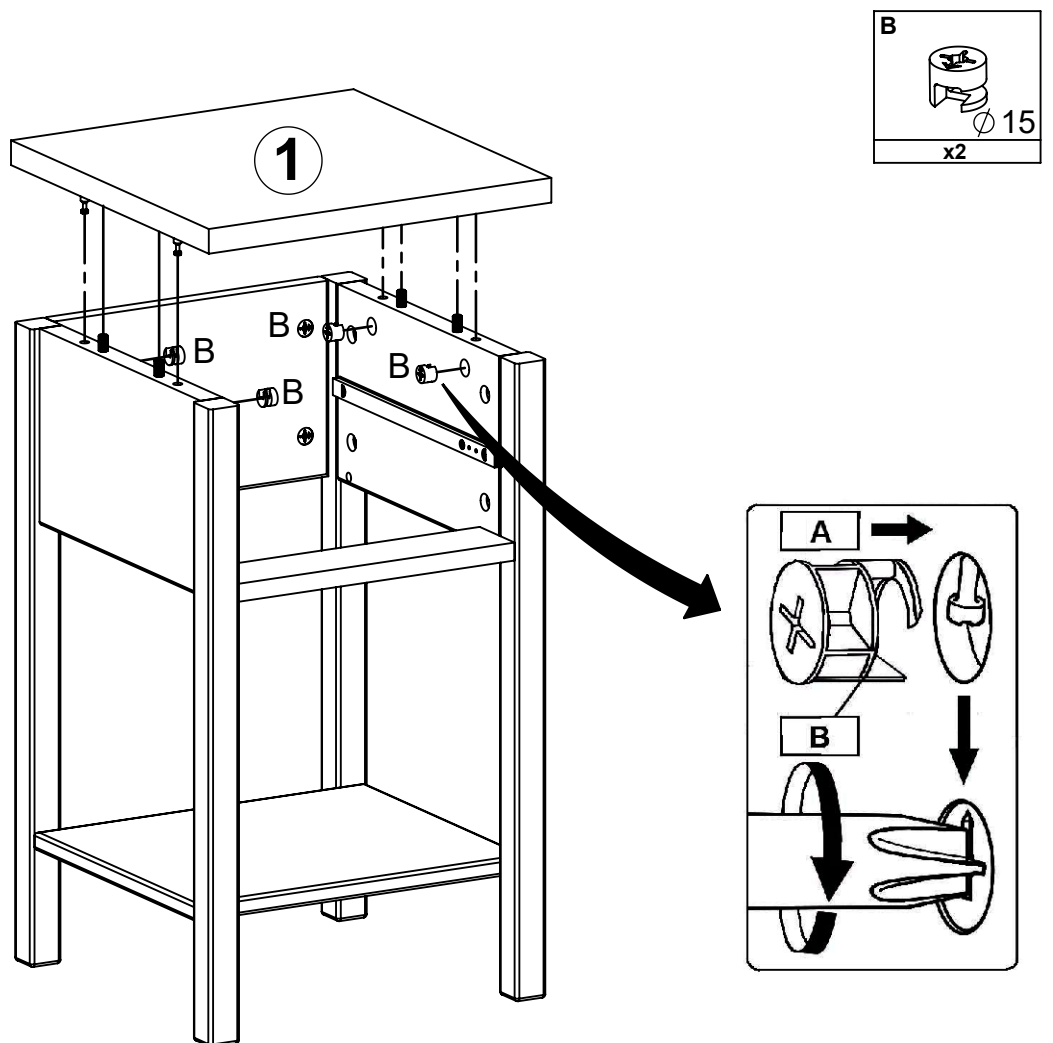

11

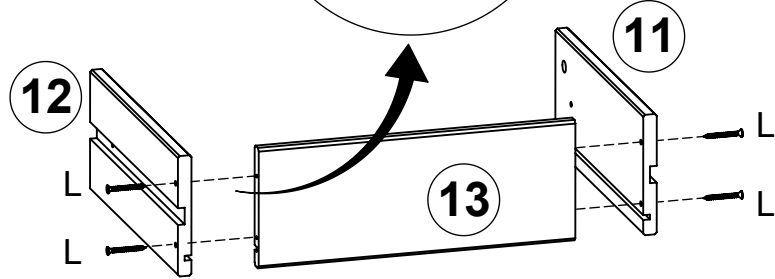
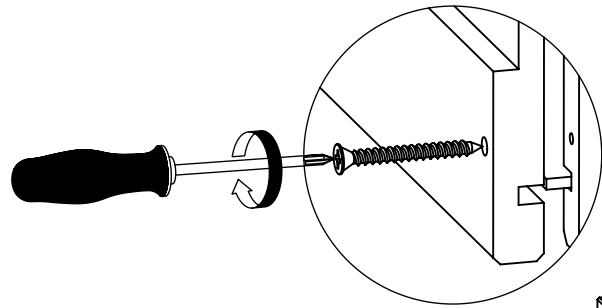
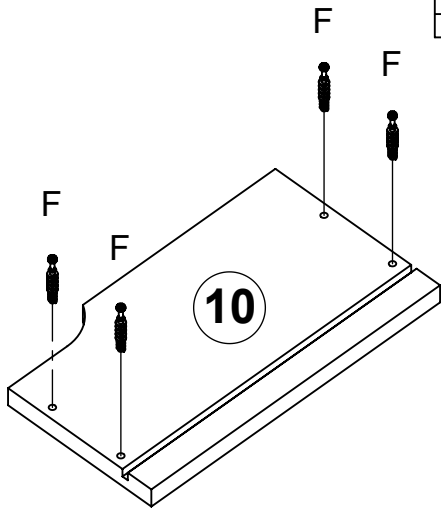
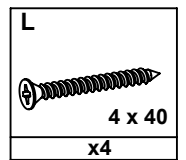
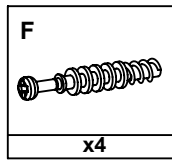

12

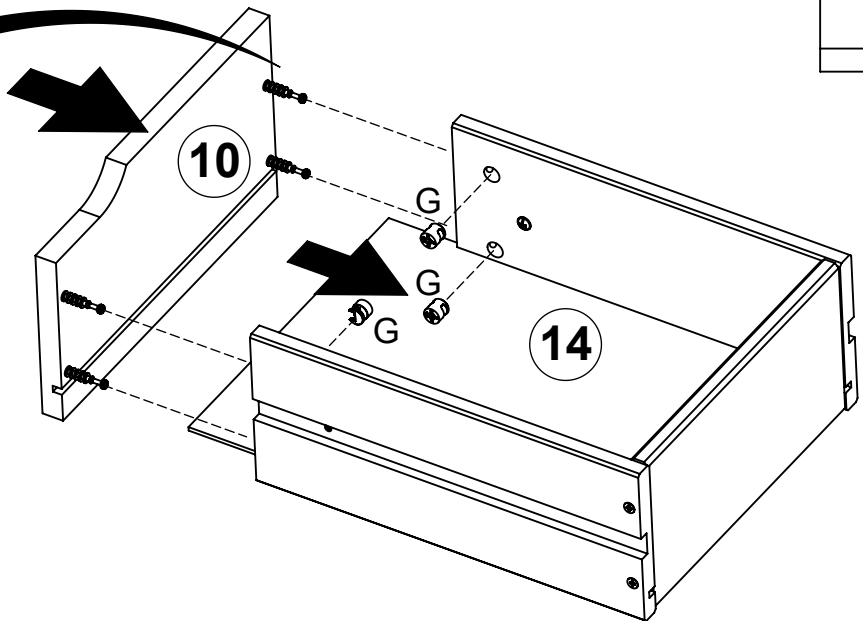
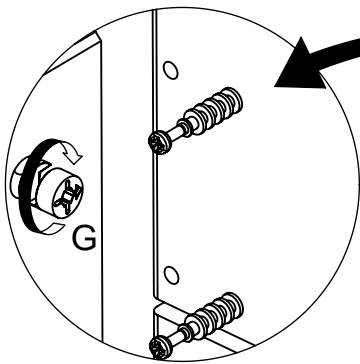
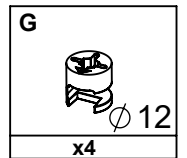

13

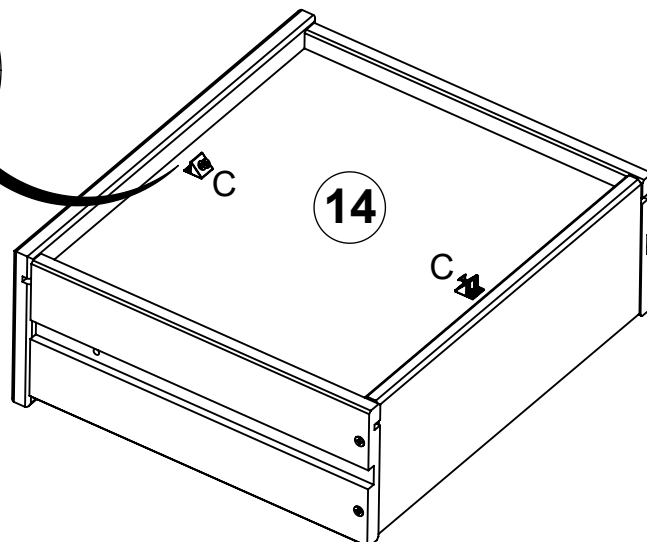
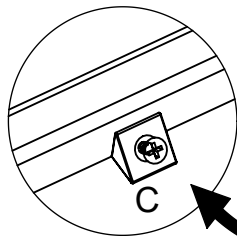
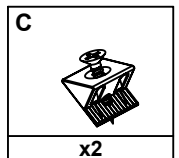

14

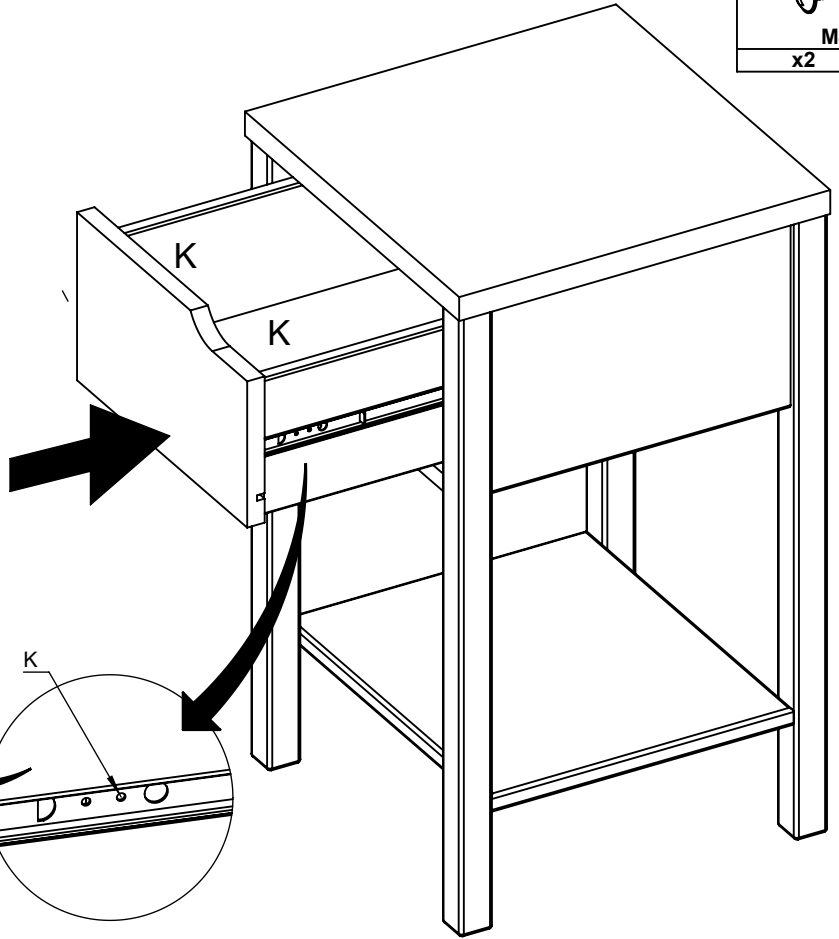
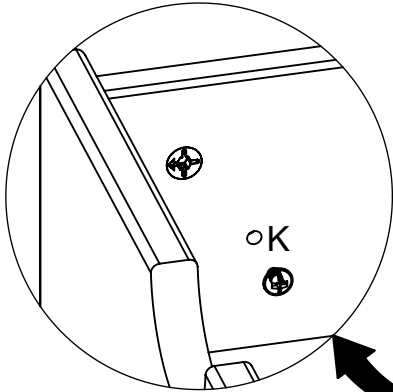
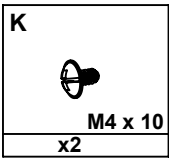
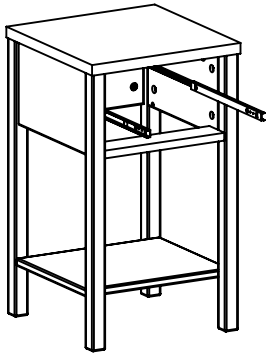

15

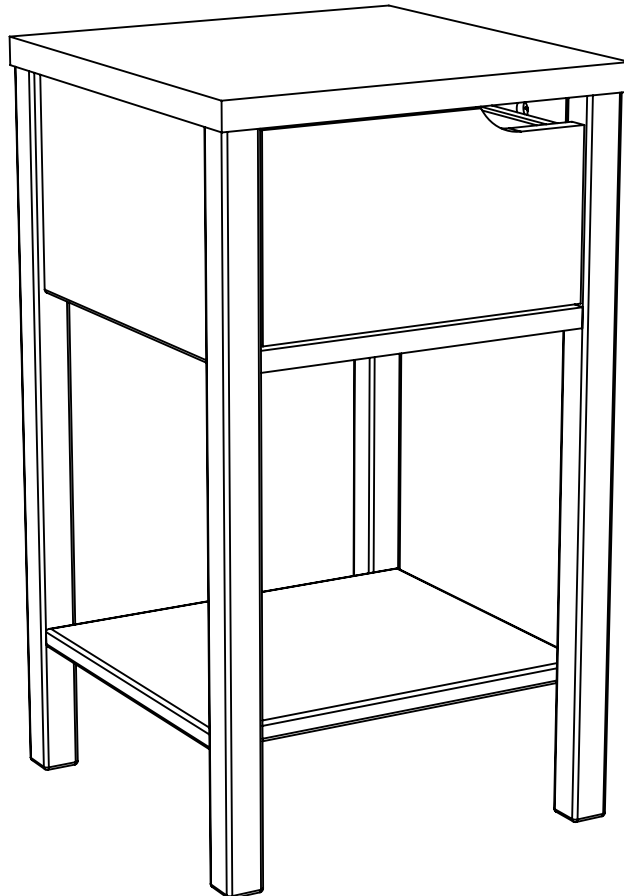

Pflege

Soin

Cura

Care

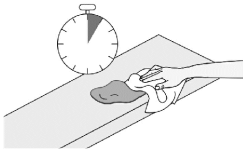

Reinigung allgemein:

Flecken immer sofort entfernen. Ein sauberes, weisses Tuch verwenden.



Sauberes Wasser verwenden. Lässt sich der Fleck so nicht entfernen, seifenhaltiges Wasser verwenden. Werden Reinigungsmittel verwendet, diese immer zuerst an einer nicht sichtbaren Stelle testen.



ACHTUNG Keine chemischen, scheuernden oder kratzenden Reinigungs-/Hilfsmittel verwenden.

Nettoyage en général:

Toujours éliminer immédiatement les taches. Utiliser un chiffon blanc, propre.

Utiliser une eau propre. Si la tache ne s'enlève pas, utiliser une eau savonneuse. Si un produit de nettoyage est utilisé, toujours l'essayer préalablement dans un endroit invisible.

ATTENTION Ne pas utiliser de produits ou moyens chimiques, agressifs ou abrasifs.

Pulizia generale:

Rimuovere sempre subito le macchie. Utilizzare un panno bianco, pulito.

Utilizzare acqua pulita. Se la macchia non viene via, utilizzare dell'acqua con sapone. Se si utilizzano dei detersivi, provarli sempre prima in un punto non visibile.

ATTENZIONE Non utilizzare detersivi chimici o prodotti/ materiali abrasivi.

General cleaning instructions:

Always remove stains immediately. Use a clean, white cloth.

Use clean water. If the stain does not come out, use soapy water. If you use cleaning detergents, always test them first in a concealed spot.

CAUTION Do not use any chemical or abrasive cleaning detergents or cloths/tools.

Wartung

Entretien

Manutenzione

Maintenance



Schrauben:

Für einwandfreie, zuverlässige Funktion, Schrauben regelmässig nachziehen (z.B. vierteljährlich).

Vis:

Resserrer régulièrement les vis (p.ex. tous les 3 mois) pour assurer un fonctionnement sûr et correct.

Viti:

Per garantire un funzionamento corretto e sicuro tirare regolarmente le viti (ad es. ogni tre mesi).

Screws:

To keep your furniture in good working order, tighten the screws regularly (e.g. every three months).