

SRP-2309-75-TW-CC

75W DALI DT8 DIMMABLE LED DRIVER



Product features

- DT8 dimmable 4-channel RGBW power supply unit
- 100-277VAC wide input voltage range
- 2-channel constant current output (total output power up to 75W)
- Output current from 250mA to 1500mA selectable via DIP switches
- Class 2 power supply, completely insulated plastic housing
- High power factor and efficiency
- Built-in DALI interface, DALI DT8 device, the device can be controlled via a DALI address
- Colour control according to DALI DT8 specifications
- Complies with DALI IEC 62386-209-:2011 standard
- Generally compatible with DALI masters supporting DT8 commands
- IP20 protection class, suitable for indoor lighting projects
- 5 years warranty

Technische Daten

INPUT	Voltage Range	100-277VAC
	Frequency Range	50/60Hz
	Power Factor (typ.)	>0.96@230VAC
	Total Harmonic Distortion	THD ≤ 15% (@ full load /230VAC)
	Efficiency typ.	87% @ 230VAC full load
	AC Current (typ)	400mA @ @ 230VAC
	Inrush Current (typ)	Cold start max. 20A@230VAC
	Leakage Current	< 0.5mA/230VAC
	Stand by Power Consumption	0.5W
OUTPUT	LED Channel	2
	Setable current:	250mA, 300mA, 350mA, 400mA, 500mA, 700mA, 800mA, 900mA, 1000mA, 1100mA, 1200mA, 1300mA, 1400mA, 1500mA
	Current Tolerance	+/- 5%
	DC Voltage Range	6-48VDC
	Rated Power	max. 72W /CH, CH1+CH2≤75W
PROTECTION	Short Circuit	Yes, recovers automatically after fault condition is removed
	Over Temperature	Yes, recovers automatically after fault condition is removed
	Over Voltage	Yes, recovers automatically after fault condition is removed
CONTROL	Dimming Interface	DALI DT8
	Dimming Range	0.1% - 100%
	Dimming Methode	PWM, 1.5kHz
	Dimming Curve	Logarithmic
ENVIRONMENT	Working Temperature	-20°C - + 45°C
	Max. Case Temperature	85°C
	Working Humidity	10%-95% RH non-condensing
	Storage Temperature	-40°C - +80°C
	Storage Humidity	10% - 95% RH
	IP Rating	IP20 (suitable for indoor LED lighting applications)
Safety & EMC	Safety Standards	UL8750, CAN/CSA C22.2 No. 250.13-14, ENEC EN61347-1, EN61347-2-13 approved
	DALI Standards	Comply with IEC 62386-209:2011
	Withstand Voltage	I/P-O/P: 3.75KVAC
	Isolation Resistance	I/P-O/P: 100M Ohms / 500VDC / 25°C / 70% RH
	EMC Emission	EN55015, EN61000-3-2, EN61000-3-3
	EMC Immunity	EN61547, EN61000-4-2,3,4,5,6,8,11, , surge immunity Line-
Others	MTBF	193.6K hrs min. @ 230VAC full load and 25°C ambient temperature
	Dimension	244 x 64 x 32mm
	Warranty	5 years

Product dimension

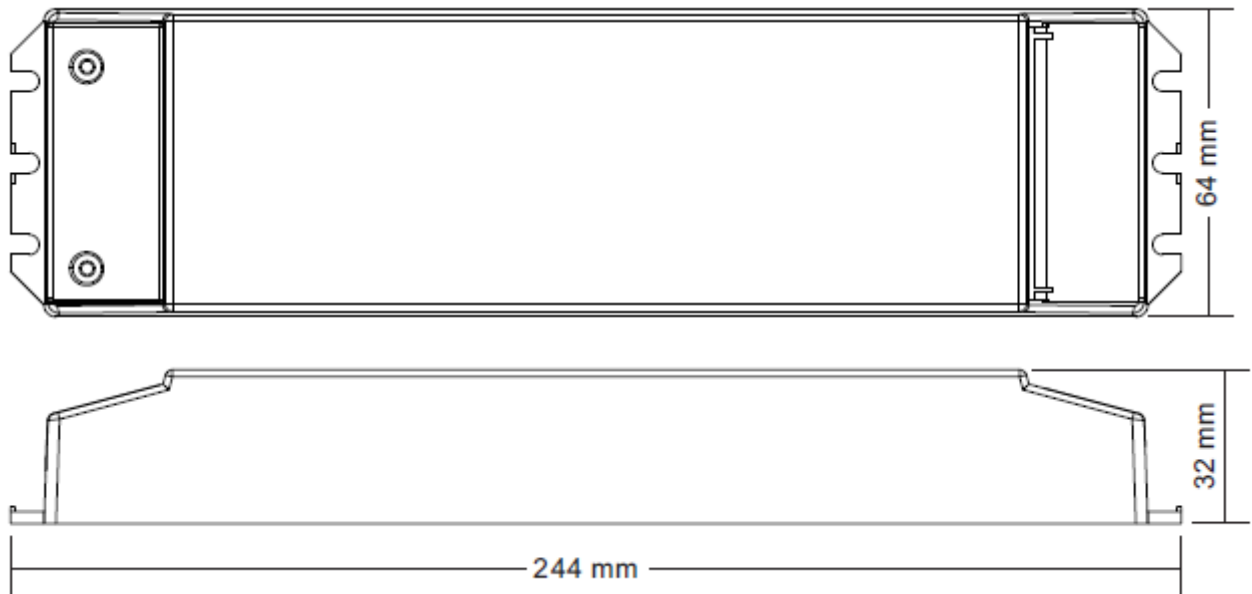

Wiring diagram

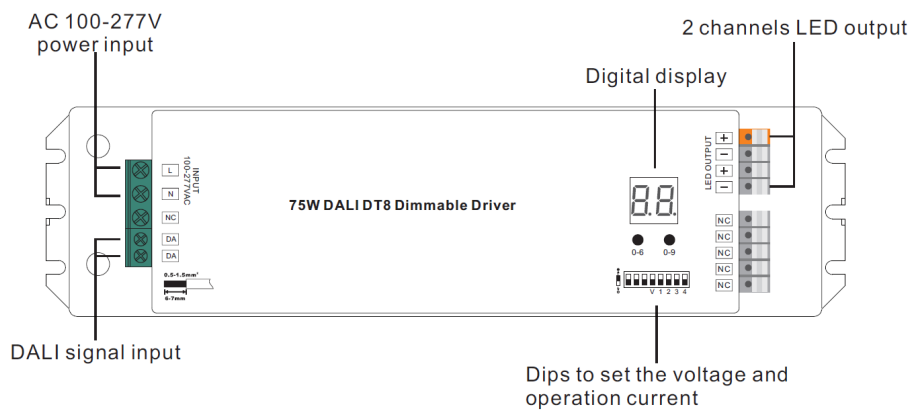
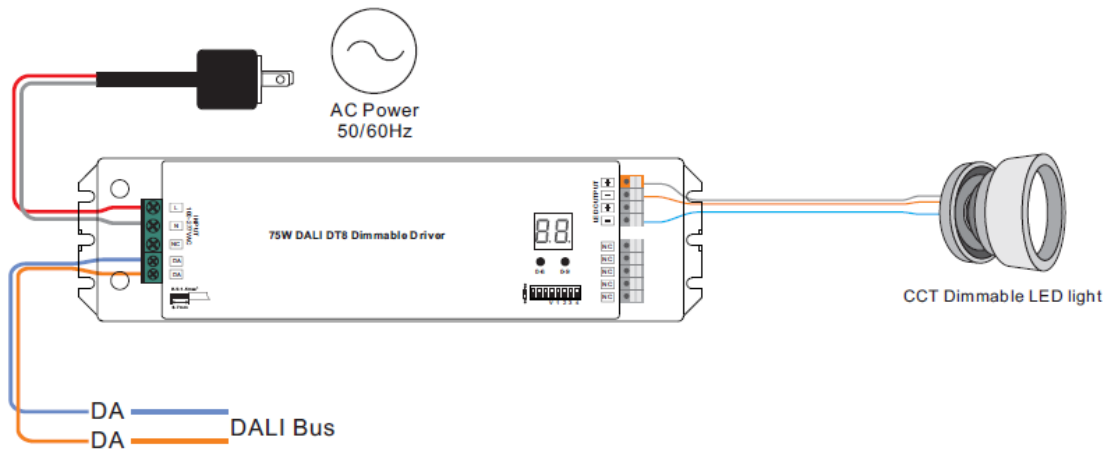

Installation

SAFETY AND WARNINGS

- **Do not install with power applied to the device**
- **Do not set operation current with power applied to the device**
- **Do not expose the device to moisture**
- **Drivers with PWM dimming can cause noise due to vibrations. These can be generated by vibrating components in the device as well as by resonant vibrations from other bodies.**



- Approved wire diameter: AWG16—AWG20 / 0.5mm²-1.5mm²

0.5-1.5mm² (AWG20-16)



6-7mm (0.24-0.28in)

Operation

Set DALI address manually via buttons

1. Press one of the two buttons until the LED display starts flashing.
2. Press one of the two buttons briefly to change the corresponding number until the desired number lights up. Use the left button to change the number by 10 units, the right button to change the number by 1 unit. The address can be set from 00-63.
3. Then press one of the two buttons until the display stops flashing.



Information: The DALI address can be set manually from 00-63-FF. No DALI address is assigned in the factory setting. The display shows FF. If the unit is manually set to FF, it is reset to the factory setting.

Assigning a DALI address via a DALI master

The DALI address can also be programmed automatically via a master. Please refer to the operating instructions of the respective DALI master.

Information: The display will show AU if the DALI Master assigns the address to the device.

If an address is set, all four channels are controlled via this address. If, for example, the dimmer is programmed to address 22 (visible on the display), CH1, CH2, CH3 and CH4 are controlled via this address.



Important Information for installation

Power on level is a DALI parameter that defines the level of a control gear after power is restored. The factory default power on level for this driver is 100, which means the driver will be at 100% intensity when power is restored.

Troubleshooting Help

Situation A: The power supply has been overloaded and is now in overload protection mode.

What does the error pattern look like?

The connected LEDs flash. You can reduce the brightness via a DALI software and the strip will stop flashing. You can no longer control the colours with the software.

How can the problem be solved (two variants A + B)?

- A.
1. Disconnect the device from the mains for at least 10 minutes. The unit will reset to factory settings.
 2. Reduce the load so that it meets the specifications of the unit.
 3. You can now operate the unit normally again.
- B.
1. Disconnect the device from the mains for at least 10 minutes. The unit will reset to the factory settings.
 2. Disconnect the load (LED strip / LED module) from the power supply.
 3. Reconnect the device to the mains.
 4. Connect the device to the DALI Master software.
 5. In the software, reduce the Power On Level and the maximum level for this device. The value must be below the maximum load of the power supply.
 6. Disconnect the device from the power supply and reattach the load.
 7. You can now operate the device normally again.