

---

**Wichtig:**  
Vor Gebrauch sorgfältig durchlesen/  
Montageanleitung für späteres Nachlesen aufbewahren

**Important:**  
Lisez attentivement/  
conserver les instructions d'installation pour référence future avant utilisation

**Importante:**  
lettura/conservare Istruzioni per l'installazione per riferimento futuro accuratamente prima dell'uso

**Important:**  
Read carefully before assembling/keep and store Instruction for reference

# EMILIO

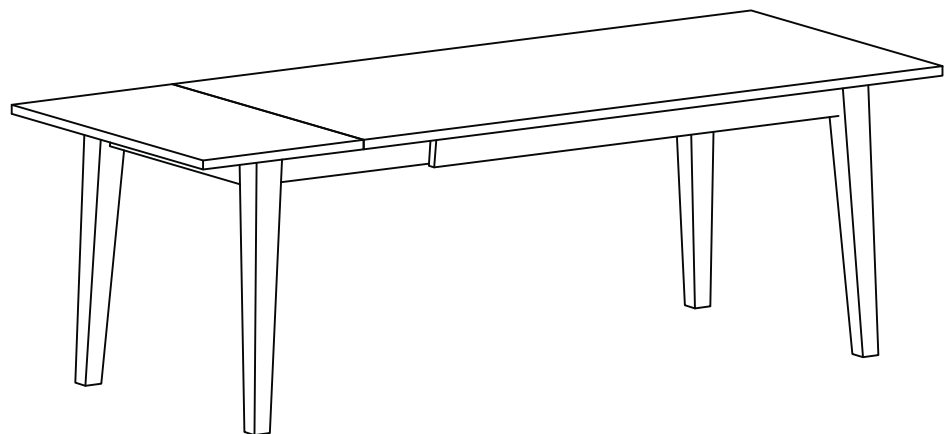
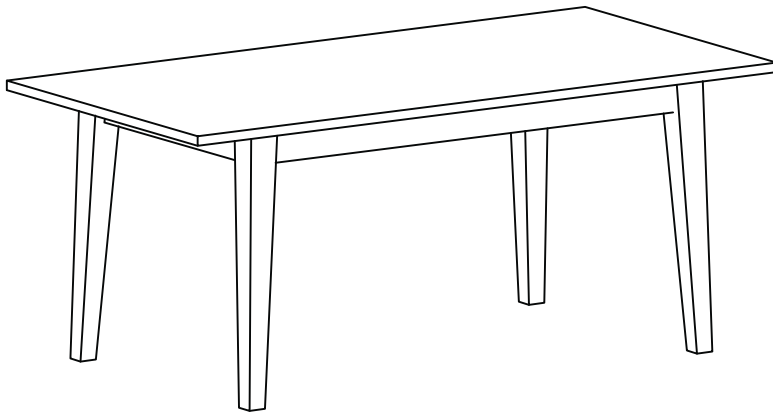



## Warnhinweise

### Bestimmungsgemässer Gebrauch:

Bitte achten Sie darauf, dass Ihre Möbel nur Ihrem Zweck gemäss verwendet werden. Für eine dauerhafte Funktionsfähigkeit ist eine sachgerechte Nutzung und regelmässige Unterhaltungspflege sehr wichtig.

## Mises en garde

### Utilisation conforme:

Veillez vous assurer que vos meubles sont utilisés uniquement pour leur usage prévu. Un entretien régulier et une utilisation conforme sont essentiels pour assurer un fonctionnement durable.

## Avvertenze

### Utilizzo per lo scopo previsto:

assicuratevi che i vostri mobili siano utilizzati solo per lo scopo per cui sono stati realizzati. Per garantire il loro funzionamento nel tempo è importante utilizzarli correttamente e sottoporli regolarmente a cure manutentive.

## Warning notice

### Intended use:

Please make sure that you only use your furniture for the purpose it was designed for. Correct use and regular maintenance are essential for ensuring your furniture remains in working order for the long-term.

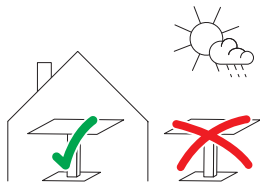

### Anwendung:

Das von Ihnen erworbene Tischmöbel eignet sich für den allgemeinen, privaten Wohnbereich. Es ist nicht für den Nass-, Aussen- oder gewerblichen Bereich geeignet.

### Usage:

La table que vous avez achetée convient pour l'habitat privé en général. Elle ne convient pas pour l'extérieur, les milieux humides ou le domaine commercial.

### Impiego:

la seduta acquistata è adatta per essere utilizzata in generale, in ambito domestico. Non è adatta per gli esterni, per l'esposizione alla pioggia o per ambienti commerciali.

### Area of use:

The table furniture you have purchased is suitable for use in general private living quarters. It is not suitable for areas that are wet, outside or used for commercial purposes.



### Anwendung:

Das Sitzen und Stehen auf Tischmöbel ist nicht gestattet, es ist kein Ersatz für Tritte oder Leitern.

### Usage:

Il n'est pas permis de s'asseoir ou de se mettre debout sur la table, elle n'est pas un substitut aux escaliers ou échelles.

### Impiego:

non è consentito sedersi o stare in piedi sul tavolo, non sostituisce un gradino o una scala.

### Area of use:

Sitting and standing on the table furniture is not permitted, the table is not a substitute for steps or ladders.



### Max. Belastung:

Tischfläche 100 kg.

### Charge max.:

100 kg par plateau.

### Carico max.:

superficie del tavolo 100 kg.

### Max. load:

Table surface 100 kg.



### WARNING

#### Verschluck- und Erstickungsgefahr:

Kleinteile und Verpackungsmaterial können verschluckt werden.

### AVERTISSEMENT

#### Risque d'ingestion et d'étouffement:

Les petites pièces et le matériel d'emballage peuvent être avalés.

### AVVERTENZA

#### Pericolo di ingestione e soffocamento:

piccole parti e materiale di imballaggio possono essere ingerite.

### WARNING

#### Risk of swallowing and choking:

Small parts and packaging material may be swallowed.



WARNING! Tüten und Folien sind kein Spielzeug! Bitte von Babys und Kleinkindern fernhalten! Nicht über den Kopf ziehen; Erstickungsgefahr!

AVERTISSEMENT! Les sacs et films ne sont pas des jouets! Veuillez les tenir hors de portée des bébés et jeunes enfants! Ne pas mettre sur la tête, risque d'étouffement!

AVVERTENZA! Sacchetti e pellicole non sono un giocattolo! Tenere lontano dalla portata dei neonati e dei bambini piccoli! Non metterli in testa, pericolo di soffocamento!

WARNING! Bags and film coverings are not toys! Please keep away from babies and small children! Do not put them over your head, risk of suffocation!



### VORSICHT,

#### Verletzungsgefahr:

Kleinkinder dürfen sich nicht im Montagebereich aufhalten und an Möbeln hochziehen oder hinaufklettern.

### PRÉCAUTION,

#### risque de blessures:

Les jeunes enfants ne peuvent pas se tenir dans la zone de montage ni tirer ou grimper sur des meubles.

### PRECAUZIONE,

#### pericolo di lesioni:

tenere i bambini lontano dal luogo di montaggio e evitare che si appendano o arrampichino sul mobile.

### PRECAUTION,

#### risk of injury:

Small children must keep away from the assembly area. They must refrain from climbing up on the furniture.

1.

## Allgemeine Hinweise

## Remarques générales

## Avvertenze generali

## General information

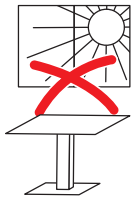

**ACHTUNG**  
**Direkte Sonneneinstrahlung:**  
Führt zu Farbveränderungen.

**ATTENTION**  
**Exposition directe au soleil:**  
Provoque des décolorations.

**ATTENZIONE**  
**Irraggiamento diretto del sole:**  
ne modifica il colore.

**ATTENTION**  
**Direct sunlight:**  
results in discolouration.

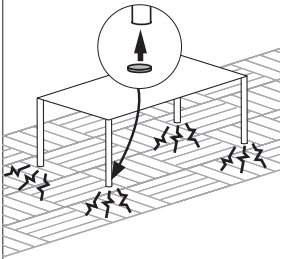

**Schutzgleiter:**  
Mit Schutzgleitern (z.B. aus Filz), lassen sich Schäden auf kratzempfindlichen Böden (z.B. Parkett) vermeiden.

**Patins:**  
Les patins (p.ex. en feutre) permettent d'éviter d'endommager les sols sensibles aux rayures (p.ex. parquet).

**Scivolante protettivo:**  
grazie agli scivolanti protettivi (ad es. feltro) si evita di danneggiare pavimenti sensibili ai graffi (ad es. parquet).

**Protective covers:**  
Protective covers, e.g. felt pads, prevent damage to floors that are easily scratched (e.g. parquet).

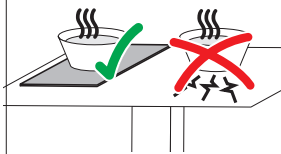

**ACHTUNG, Temperatur:**  
Nie heiße oder sehr kalte Objekte direkt auf die Oberfläche stellen. Geeigneten Schutz verwenden, z.B. Untersteller.

**ATTENTION, température:**  
Ne jamais poser des objets chauds ou très froids directement sur la surface. Utiliser une protection appropriée, p.ex. sous-plat.

**ATTENZIONE, temperatura:** non appoggiare mai oggetti caldi o molto freddi direttamente sulla superficie. Utilizzare una protezione adatta, ad es. un sotto piatto.

**ATTENTION, temperature:**  
Do not place hot or cold objects directly on the surface. Use the appropriate protection, e.g. saucer.

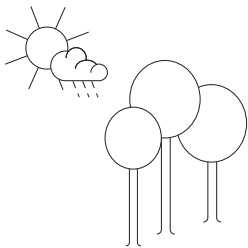

**Holzprodukte:**  
Holz ist ein natürlicher Rohstoff. Jeder Baum ist abhängig vom Standort verschiedensten Einflüssen, wie Klima etc., ausgesetzt. Durch diese Einflüsse wird das Erscheinungsbild (Farbe, Äste, Maserung etc.) des Holzes massgeblich beeinflusst. Abhängig von der Luftfeuchtigkeit und Temperatur, hat Holz die Eigenschaft, sich auszudehnen und kleiner zu werden. Dies kann zu Rissen führen.

**Veränderungen und Naturmerkmale sind natürlich und dadurch ist jedes Massivholzmöbelstück ein Unikat.**

**Produits en bois:**  
Le bois est une matière naturelle. Chaque arbre est exposé à diverses influences, comme le climat etc., en fonction de son lieu de plantation. L'aspect du bois (teinte, nœuds, grain etc.) est fortement conditionné par ces influences. Le bois a la propriété de se dilater ou de se rétracter en fonction de l'humidité et de la température. Cela peut provoquer des fissures.

**Ces caractéristiques naturelles et les changements sont normaux, ce qui fait de chaque meuble en bois une pièce unique.**

**Prodotti di legno:**  
il legno è una materia prima naturale. Ogni albero, a seconda del luogo in cui cresce, è esposto a diverse influenze come il clima, ecc. Grazie a questi agenti, l'aspetto (colore, rami, venatura, ecc.) del legno viene fortemente influenzato. A seconda dell'umidità dell'aria e della temperatura, il legno ha la capacità di espandersi e ritirarsi. Questo può portare alla formazione di crepe.

**La trasformazione e le caratteristiche sono naturali e, pertanto, ogni mobile di legno massiccio è unico nel suo genere.**

**Wooden products:**  
Wood is a natural raw material. Each tree is subjected to a whole variety of influences, e.g. the climate, depending on its location. These influences are decisive in creating the way the wood ultimately looks (colour, knots, grain, etc.) Depending on the humidity and temperature, wood is capable of expanding and contracting. As a result cracks may form.

**Changes and natural characteristics are natural, so each piece of solid wood furniture completely unique.**



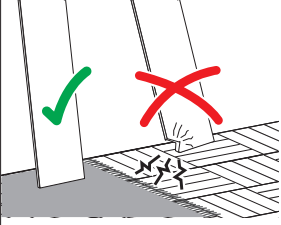

<b>1.</b>	<b>Allgemeine Hinweise</b>	<b>Remarques générales</b>	<b>Avvertenze generali</b>	<b>General information</b>
	<b>Unikat:</b> Dieses Produkt wurde von Hand hergestellt und jedes Stück ist einzigartig.	<b>Pièce unique:</b> Ce produit a été réalisé à la main et chaque pièce est unique.	<b>Esemplare unico:</b> questo prodotto è stato realizzato a mano e ogni esemplare è un pezzo unico.	<b>Unique:</b> This product has been made by hand and therefore each piece is unique.

<b>2.</b>	<b>Montagehinweise</b>	<b>Instructions de montage</b>	<b>Istruzioni di montaggio</b>	<b>Assembly information</b>
	<b>Montageschäden:</b> Vermeiden Sie indem Sie einen sauberen und weichen Untergrund verwenden (z.B. Teppich). Teile beim Auspacken oder während der Montage nur auf weiche Unterlagen legen/stellen. Darauf achten, dass grössere Teile nicht kippen können.	<b>Dommages au montage:</b> Évitez les dommages en utilisant un fond propre et doux (p.ex. tapis). Lors du déballage et montage, posez/placez les éléments uniquement sur un fond doux. Assurez-vous que les grands éléments ne peuvent pas basculer.	<b>Danni in fase di montaggio:</b> evitare di causare danni utilizzando una base pulita e morbida (ad es. tappeto). Nella fase di disimballaggio e durante il montaggio, appoggiare i pezzi esclusivamente su una base morbida. Fare attenzione che i pezzi più grandi non si ribaltino.	<b>Damages during assembly:</b> These can be avoided if you use a clean soft surface (e.g. carpet). Only place parts on a soft surface when unpacking or during the assembly. Make sure that larger parts cannot tip over.

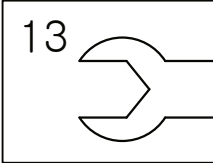
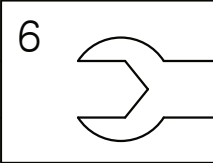
	<b>Personen:</b> Für die Montage erforderliche Anzahl Personen.	<b>Personnes:</b> Nombre de personnes nécessaires au montage.	<b>Persone:</b> numero di persone necessarie per il montaggio.	<b>People:</b> Number of people required for the assembly.
---	--	--	---	---

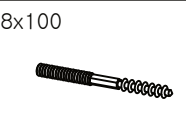
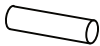
	<b>Montagerichtzeit:</b> Ungefähre Zeit in Stunden.	<b>Durée indicative du montage:</b> Durée approximative en heures.	<b>Tempo di montaggio:</b> tempo in ore approssimativo.	<b>Assembly time:</b> Approximate time in hours.
---	--	---	--	---

<b>Benötigtes Werkzeug</b>	<b>Outils nécessaires</b>	<b>Attrezzi necessari</b>	<b>Tools required</b>
			

<b>Bau-/Kleinteile:</b>	<b>Éléments / pièces:</b>	<b>Componenti / piccoli pezzi</b>	<b>Components / small parts</b>
			
A x2	B x4	C x4	
			
D x4	E x6	F x2	

3.

Montage-  
anleitung

Instructions de  
montage

Istruzioni per  
il montaggio

Assembling  
instruction

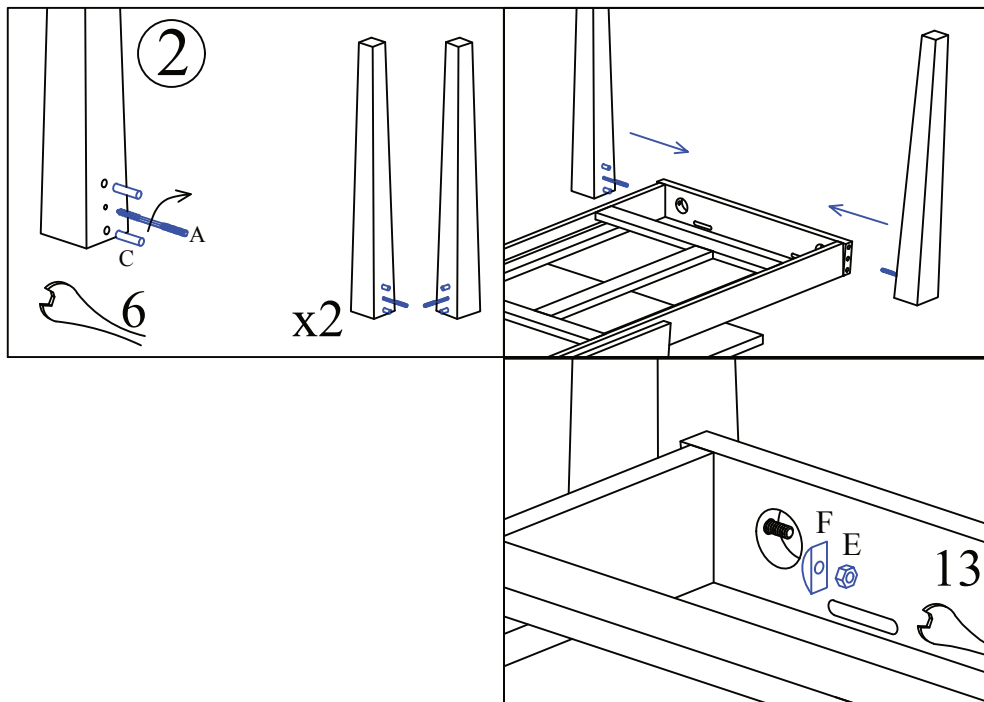
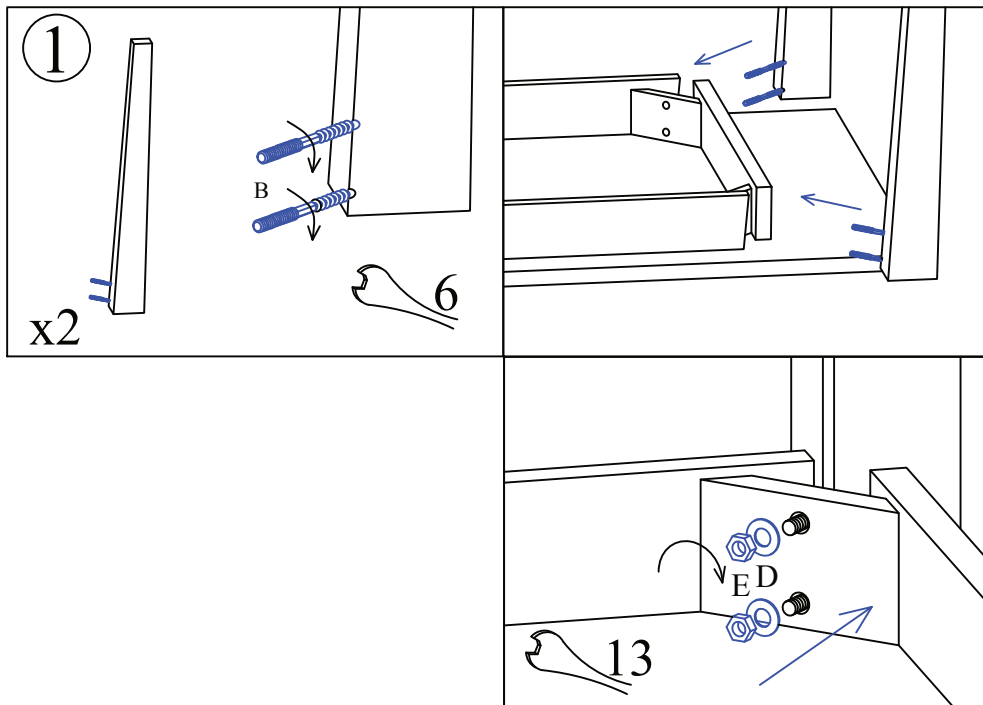

3.

Montage-  
anleitung

Instructions de  
montage

Istruzioni per  
il montaggio

Assembling  
instruction

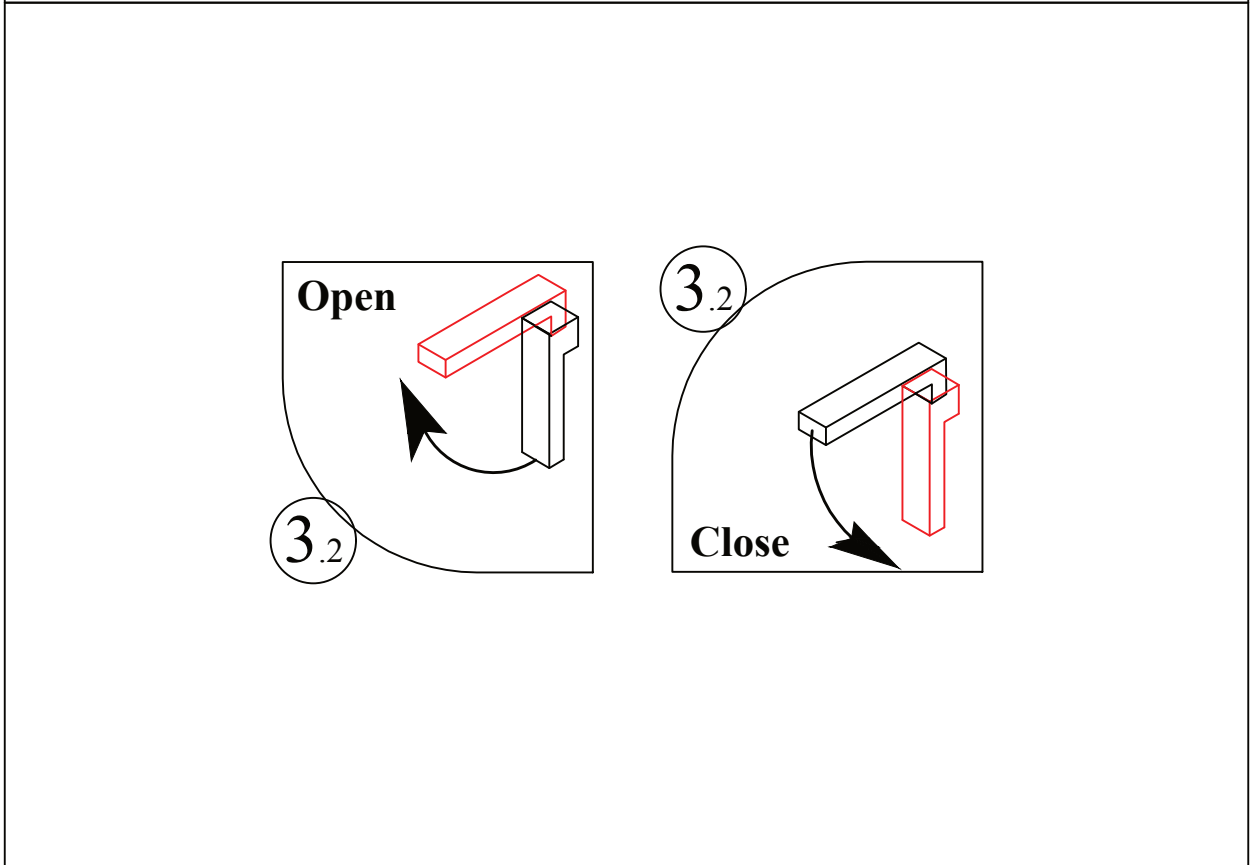
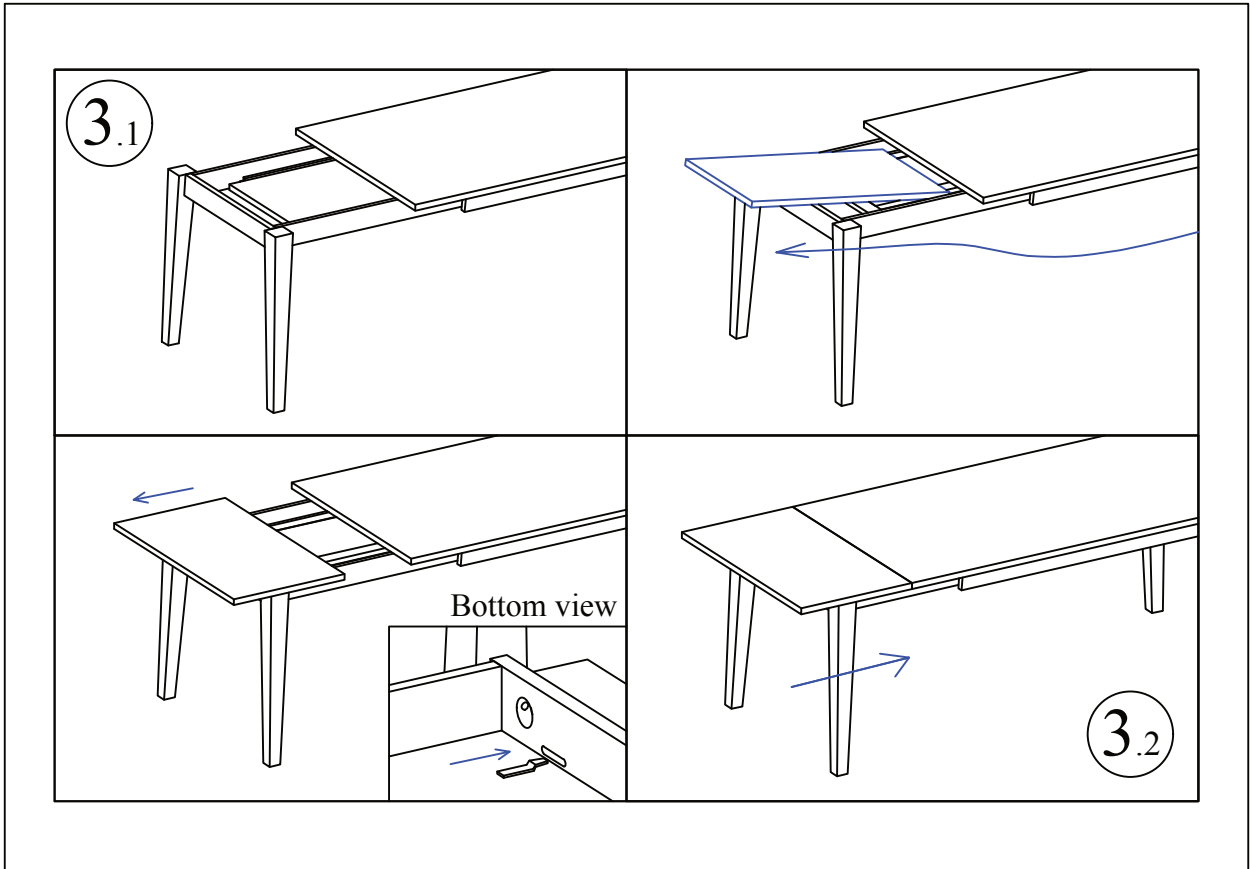

**Reinigung allgemein:**

Flecken immer sofort entfernen. Ein sauberes, weisses Tuch verwenden.



Sauberes Wasser verwenden. Lässt sich der Fleck so nicht entfernen, seifenhaltiges Wasser verwenden. Werden Reinigungsmittel verwendet, diese immer zuerst an einer nicht sichtbaren Stelle testen.



**ACHTUNG** Keine chemischen, scheuern- oder kratzenden Reinigungs-/Hilfsmittel verwenden.

**Nettoyage en général:**

Toujours éliminer immédiatement les taches. Utiliser un chiffon blanc, propre.

Utiliser une eau propre. Si la tache ne s'enlève pas, utiliser une eau savonneuse. Si un produit de nettoyage est utilisé, toujours l'essayer préalablement dans un endroit invisible.

**ATTENTION** Ne pas utiliser de produits ou moyens chimiques, agressifs ou abrasifs.

**Pulizia generale:**

rimuovere sempre subito le macchie. Utilizzare un panno bianco, pulito.

Utilizzare acqua pulita. Se la macchia non viene via, utilizzare dell'acqua con sapone. Se si utilizzano dei detergenti, provarli sempre prima in un punto non visibile.

**ATTENZIONE** Non utilizzare detergenti chimici o prodotti/materiali abrasivi.

**General cleaning instructions:**

Always remove stains immediately. Use a clean, white cloth.

Use clean water. If the stain does not come out, use soapy water. If you use cleaning detergents, always test them first in a concealed spot.

**CAUTION** Do not use any chemical or abrasive cleaning detergents or cloths/tools.

**Möbelpflege:**

Lackiertes Holz nur mit einem leicht feuchten Tuch abwischen.

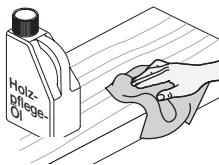

Geölte Holzoberflächen je nach Gebrauch, von Zeit zu Zeit (z.B. halbjährlich) erneut ölen.

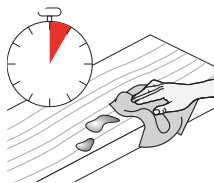

Feuchtigkeitsrückstände auf geölte und gewachste Flächen müssen sofort entfernt werden. Ansonsten kommt es zu Fleckenbildung.



**ACHTUNG** Keine chemischen, scheuern- oder kratzenden Reinigungs-/Hilfsmittel verwenden.

**Entretien des meubles:**

Essuyer le bois vernis uniquement avec un chiffon légèrement humide.

Pour les surfaces en bois huilé, appliquer de temps à autre (p.ex. tous les 6 mois) et en fonction de l'utilisation une huile pour bois.

Les restes d'humidité sur les surfaces huilées et cirées doivent être immédiatement enlevés. Risque de formation de taches.

**ATTENTION** Ne pas utiliser de produits ou moyens chimiques, agressifs ou abrasifs.

**Cura dei mobili:**

pulire il legno laccato utilizzando soltanto un panno leggermente umido.

Le superfici di legno oliate di tanto in tanto, a seconda del loro utilizzo (ad es. ogni sei mesi), devono essere nuovamente trattate con olio.

È necessario eliminare subito i residui di umidità dalle superfici oliate e cerate, altrimenti c'è il rischio che si formino delle macchie.

**ATTENZIONE** Non utilizzare detergenti chimici o prodotti/materiali abrasivi.

**Furniture care:**

Only wipe varnished wood with a slightly damp cloth.

Re-oil oiled wooden surfaces from time to time (e.g. every half a year) depending on use.

To prevent stains, immediately wipe off any wet spots on oiled and waxed surfaces.

**CAUTION** Do not use any chemical or abrasive cleaning detergents or cloths/tools.

5.	Wartung	Entretien	Manutenzione	Maintenance
	<b>Schrauben:</b> Für einwandfreie, zuverlässige Funktion, Schrauben regelmäßig nachziehen (z.B. halbjährlich).	<b>Vis:</b> Resserer régulièrement les vis (p.ex. tous les 6 mois) pour assurer un fonctionnement sûr et correct.	<b>Viti:</b> per garantire un funzionamento corretto e sicuro tirare regolarmente le viti (ad es. ogni sei mesi)	<b>Screws:</b> To keep your furniture in good working order, tighten the screws regularly (e.g. every six months).

6.	Entsorgung	Élimination	Smaltimento	Disposal
	Entsorgungsservice: Micasa bietet Ihnen einen Entsorgungsservice an. Weitere Informationen erhalten Sie unter <a href="http://www.micasa.ch">www.micasa.ch</a> Entsorgung: Nicht mehr verwendete Möbel der fachgerechten Entsorgung übergeben. Wenden Sie sich an Ihre lokale Entsorgungsstelle.	Service d'élimination: Micasa vous propose un service d'élimination. Vous trouverez des informations supplémentaires sur <a href="http://www.micasa.ch">www.micasa.ch</a> Élimination: Veuillez remettre les meubles qui ne sont plus utilisés à une entreprise d'élimination. Adressez-vous à votre centre de collecte local.	Servizio di smaltimento: Micasa vi offre un servizio di smaltimento. Ulteriori informazioni sono disponibili su <a href="http://www.micasa.ch">www.micasa.ch</a> Smaltimento: i mobili dismessi devono essere conferiti presso i centri di raccolta rifiuti per il loro corretto smaltimento. Rivolgersi presso il centro di raccolta locale.	Disposal service: Micasa offers a disposal service. For more information visit <a href="http://www.micasa.ch">www.micasa.ch</a> Disposal: To correctly dispose of furniture that is no longer used, contact your local recycling centre.

7.	Kontakt / Service	Contact / service	Contatto / servizio	Contact / service
	Fragen / Anregungen: Wir sind gerne für Sie erreichbar: Montag bis Freitag 08.00 bis 18.00 Uhr Samstag 08.30 bis 16.30 Uhr Tel. 0800 840 848	Questions / suggestions: Nous sommes à votre disposition: Lundi - vendredi 08h00 à 18h00 Samedi 08h30 à 16h30 Tél. 0800 840 848	Domande / suggerimenti: siamo a vostra disposizione: lunedì - venerdì dalle 08.00 alle 18.00 sabato dalle 08.30 alle 16.30 Tel. 0800 840 848	Questions / Suggestions Please contact us. Our opening times are: Monday - Friday 8.00 to 18.00 Saturday 8.30 to 16.30 Phone 0800 840 848

	Ersatzteile: Erhalten Sie direkt im Online-Shop von Migros-Service: <a href="http://www.migros-service.ch">www.migros-service.ch</a>	Pièces de rechange: Vous les obtenez directement dans le magasin en ligne de Migros-Service: <a href="http://www.migros-service.ch">www.migros-service.ch</a>	Pezzi di ricambio: sono disponibili direttamente sull'online-shop di Migros-Service: <a href="http://www.migros-service.ch">www.migros-service.ch</a>	Spare parts: Available directly from the Migros-Service online shop: <a href="http://www.migros-service.ch">www.migros-service.ch</a>
---	--	---	---	---