

Wichtig:

Vor Gebrauch sorgfältig durchlesen/
Montageanleitung für
späteres Nachlesen
aufbewahren

Important:

Lisez attentivement/
conserver les instruc-
tions d'installation
pour référence future
avant utilisation

Importante:

lettura/conservare
Istruzioni per l'installa-
zione per riferimento
futuro accuratamente
prima dell'uso

Important:

Read carefully before
assembling/keep and
store Instruction for
reference

JÉRÔME

Art. 4077.423.000.00

Art. 4077.424.000.00

Art. 4077.425.000.00

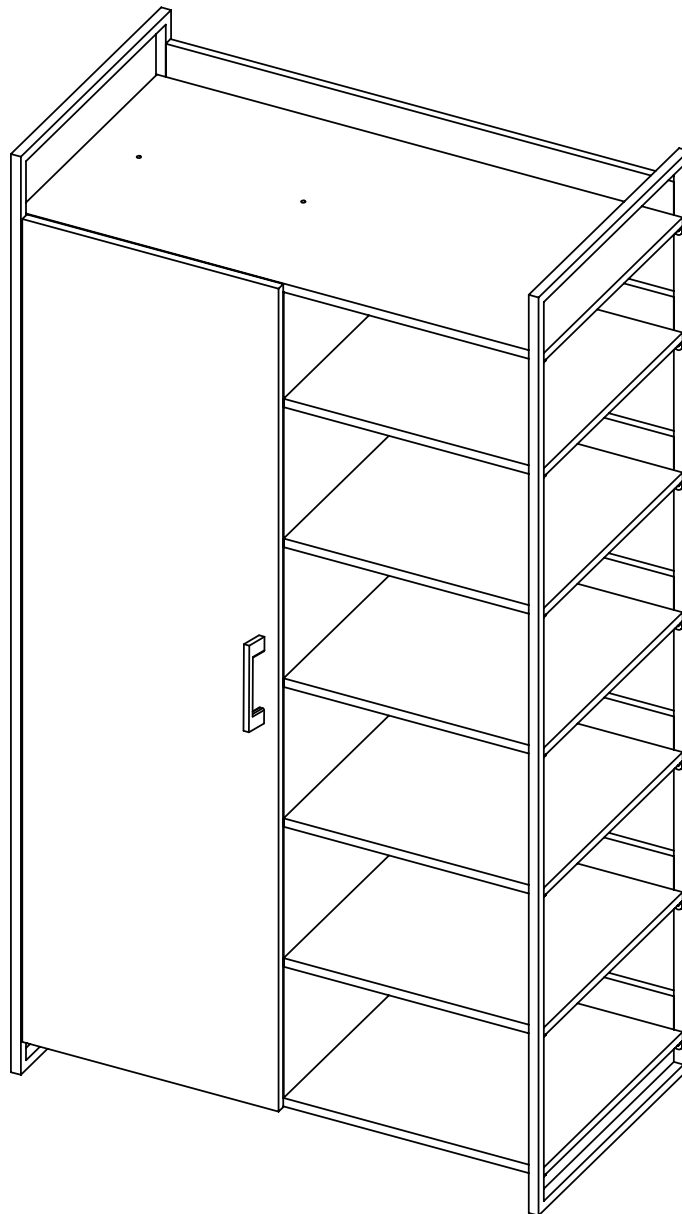



Warnhinweise

Bestimmungsgemässer Gebrauch:

Bitte achten Sie darauf, dass Ihre Möbel nur Ihrem Zweck gemäss verwendet werden. Für eine dauerhafte Funktionsfähigkeit, ist eine sachgerechte Nutzung und regelmässige Unterhaltspflege sehr wichtig.

Mises en garde

Utilisation conforme:

Veillez vous assurer que vos meubles sont utilisés uniquement pour leur usage prévu. Un entretien régulier et une utilisation conforme sont essentiels pour assurer un fonctionnement durable.

Avvertenze

Utilizzo per lo scopo previsto:

assicuratevi che i vostri mobili siano utilizzati solo per lo scopo per cui sono stati realizzati. Per garantire il loro funzionamento nel tempo è importante utilizzarli correttamente e sottoporli regolarmente a cure manutentive.

Warning notice

Intended use:

Please make sure that you only use your furniture for the purpose it was designed for. Correct use and regular maintenance are essential for ensuring your furniture remains in working order for the long-term.

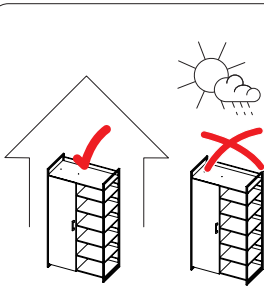

Anwendung:

Die von Ihnen erworbenen Möbel eignen sich für den allgemeinen privaten Wohnbereich. Es ist nicht geeignet für Bereiche, die nass, im Freien oder gewerblich genutzt werden.

Usage:

Les meubles que vous avez achetés conviennent à des logements privés en général. Il ne convient pas aux zones humides, à l'extérieur ou utilisées à des fins commerciales.

Impiego:

I mobili che hai acquistato sono adatti per abitazioni private in genere. Non è adatto per aree bagnate, all'aperto o utilizzate per scopi commerciali.

Area of use:

The furniture you have purchased is suitable for general private living quarters. It is not suitable for areas that wet, out-side or used for commercial purpose.



Benutzung:

Sie dürfen nicht auf dem Regal sitzen/ stehen.

Das Regal ist kein Ersatz für Stufen oder Leitern

Utilisation:

Vous ne devez pas vous asseoir/debout sur l'étagère.

L'étagère ne remplace pas les marches ou les échelles

Utilizzo:

Non devi sederti/in piedi sullo scaffale.

La mensola non sostituisce gradini o scal

Use:

You must not sit/standing on the shelf.

The shelf is not a substitute for steps or ladders

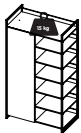

Max. Belastung:

Pro Regal 15kg.

Charge max.:

Par étagère 15kg.

Carico max.:

Per ripiano 15 kg.

Max. load:

Per Shelf 15kg.



WARNUNG Verschluck- und Erstickungsgefahr:

Kleinteile und Verpackungsmaterial können verschluckt werden.

AVERTISSEMENT Risque d'ingestion et d'étouffement:

Les petites pièces et le matériel d'emballage peuvent être avalés.

AVVERTENZA Pericolo di ingestione e soffocamento:

piccole parti e materiale di imballaggio possono essere ingerite.

WARNING Risk of swallowing and choking:

Small parts and packaging material may be swallowed.



WARNUNG! Tüten und Folien sind kein Spielzeug! Bitte von Babys und Kleinkindern fernhalten! Nicht über den Kopf ziehen; Erstickungsgefahr!

AVERTISSEMENT! Les sacs et films ne sont pas des jouets! Veuillez les tenir hors de portée des bébés et jeunes enfants! Ne pas mettre sur la tête, risque d'étouffement!

AVVERTENZA! Sacchetti e pellicole non sono un giocattolo! Tenere lontano dalla portata dei neonati e dei bambini piccoli! Non metterli in testa, pericolo di soffocamento!

WARNING! Bags and film coverings are not toys! Please keep away from babies and small children! Do not put them over your head, risk of suffocation!



**Warnhinweise****Mises en garde****Avvertenze****Warning notice**

VORSICHT, Verletzungsgefahr:
Kleinkinder dürfen sich nicht im Montage-Bereich aufhalten und an Möbeln hochziehen oder hinaufklettern.

PRÉCAUTION, risque de blessures:
Les jeunes enfants ne peuvent pas se tenir dans la zone de montage ni tirer ou grimper sur des meubles.

PRECAUZIONE, pericolo di lesioni:
tenere i bambini lontano dal luogo di montaggio e evitare che si appendano o arrampichino sul mobile.

PRECAUTION, risk of injury:
Small children must keep away from the assembly area. They must refrain from climbing up on the furniture.



Altersfreigabe:
Nicht für Kinder unter drei Jahren geeignet.

Age minimum:
Ne convient pour les enfants de moins de trois ans.

Limite di età:
non adatto per bambini sotto i tre anni.

Age restriction:
Not suitable for children under three.

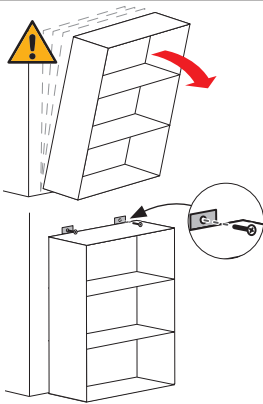

VORSICHT, dieses Möbel kann Kippen.
Um dies zu verhindern, muss es mit Kippsicherung(en) an der Wand / Decke befestigt werden. Die Befestigung ist abhängig von der Wand-/ Deckenbeschaffenheit (z.B. Beton/Gips/Backstein/Holz) und muss von einem Fachmann ausgeführt werden.

PRÉCAUTION, ce meuble peut basculer.
Pour empêcher cela, il doit être fixé au mur/plafond avec une sécurité anti-basculement. La fixation dépend de la nature du mur/plafond (p.ex. béton/plâtre/brique/bois) et doit être réalisée par un spécialiste.

PRECAUZIONE, questo mobile può ribaltarsi.
Per evitare questo, deve essere adeguatamente fissato alla parete o al soffitto. Il tipo di fissaggio dipende dalle caratteristiche della parete o del soffitto (ad es. cemento/gesso/mattone/legno) e il fissaggio deve essere eseguito da un esperto.

PRECAUTION, this piece of furniture can tip over.
To prevent this it must be secured to the wall or ceiling with brackets. The type of bracket depends on the quality of the wall and/or ceiling (e.g. concrete, plaster, brick, wood) and must be mounted by a specialist.

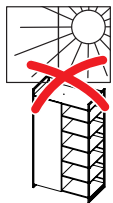
1.**Allgemeine Hinweise****Remarques générales****Avvertenze generali****General information**

ACHTUNG Direkte Sonneneinstrahlung:
Führt zu Farbveränderungen.

ATTENTION Exposition directe au soleil:
Provoque des décolorations.

ATTENZIONE Irraggiamento diretto del sole:
ne modifica il colore.

ATTENTION Direct sunlight:
results in discolouration.



ACHTUNG, Temperatur:
Nie heiße oder sehr kalte Objekte direkt auf die Oberfläche stellen. Geeigneten Schutz verwenden, z.B. Untersteller.

ATTENTION, température:
Ne jamais poser des objets chauds ou très froids directement sur la surface. Utiliser une protection appropriée, p.ex. sous-plat.

ATTENZIONE, temperatura: non appoggiare mai oggetti caldi o molto freddi direttamente sulla superficie. Utilizzare una protezione adatta, ad es. un sotto piatto.

ATTENTION, temperature:
Do not place hot or cold objects directly on the surface. Use the appropriate protection, e.g. saucer.

2.

Montagehinweise

Instructions de montage

Istruzioni di montaggio

Assembly information

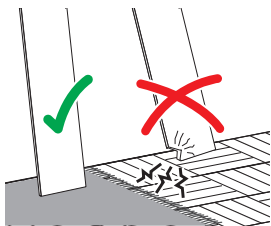

Montageschäden:

Vermeiden Sie, indem Sie einen sauberen und weichen Untergrund verwenden (z.B. Teppich). Teile beim Auspacken oder während der Montage nur auf weiche Unterlagen legen/stellen. Darauf achten, dass grössere Teile nicht kippen können.

Dommages au montage:

Évitez les dommages en utilisant un fond propre et doux (p.ex. tapis). Lors du déballage et montage, posez/placez les éléments uniquement sur un fond doux. Assurez-vous que les grands éléments ne peuvent pas basculer.

Danni in fase di montaggio:

evitare di causare danni utilizzando una base pulita e morbida (ad es. tappeto). Nella fase di disimballaggio e durante il montaggio, appoggiare i pezzi esclusivamente su una base morbida. Fare attenzione che i pezzi più grandi non si ribaltino.

Damages during assembly:

These can be avoided if you use a clean soft surface (e.g. carpet). Only place parts on a soft surface when unpacking or during the assembly. Make sure that larger parts can not tip over.



Personen:

Für die Montage werden zwei Personen benötigt.

Personnes:

Deux personnes sont requises pour le montage.

Persone:

Per il montaggio sono necessarie due persone.

People:

Assembling 2 person.



Montagerichtzeit:

Montagerichtzeit 30 Minuten.

Durée indicative du montage:

Temps de montage indicatif 30 minutes.

Tempo di montaggio:

Tempo indicativo per il montaggio 30 minuti.

Assembly time:

Assembling time in 30 minutes.



Benötigtes Werkzeug:

Outils nécessaires:

Attrezzi necessari:

Tools required:

2.

Montage-
hinweise

Instructions de
montage

Istruzioni di
montaggio

Assembly
information

Bau-/Kleinteile:

Éléments / pièces:

Componenti/
piccoli pezzi:

Components/
small parts:

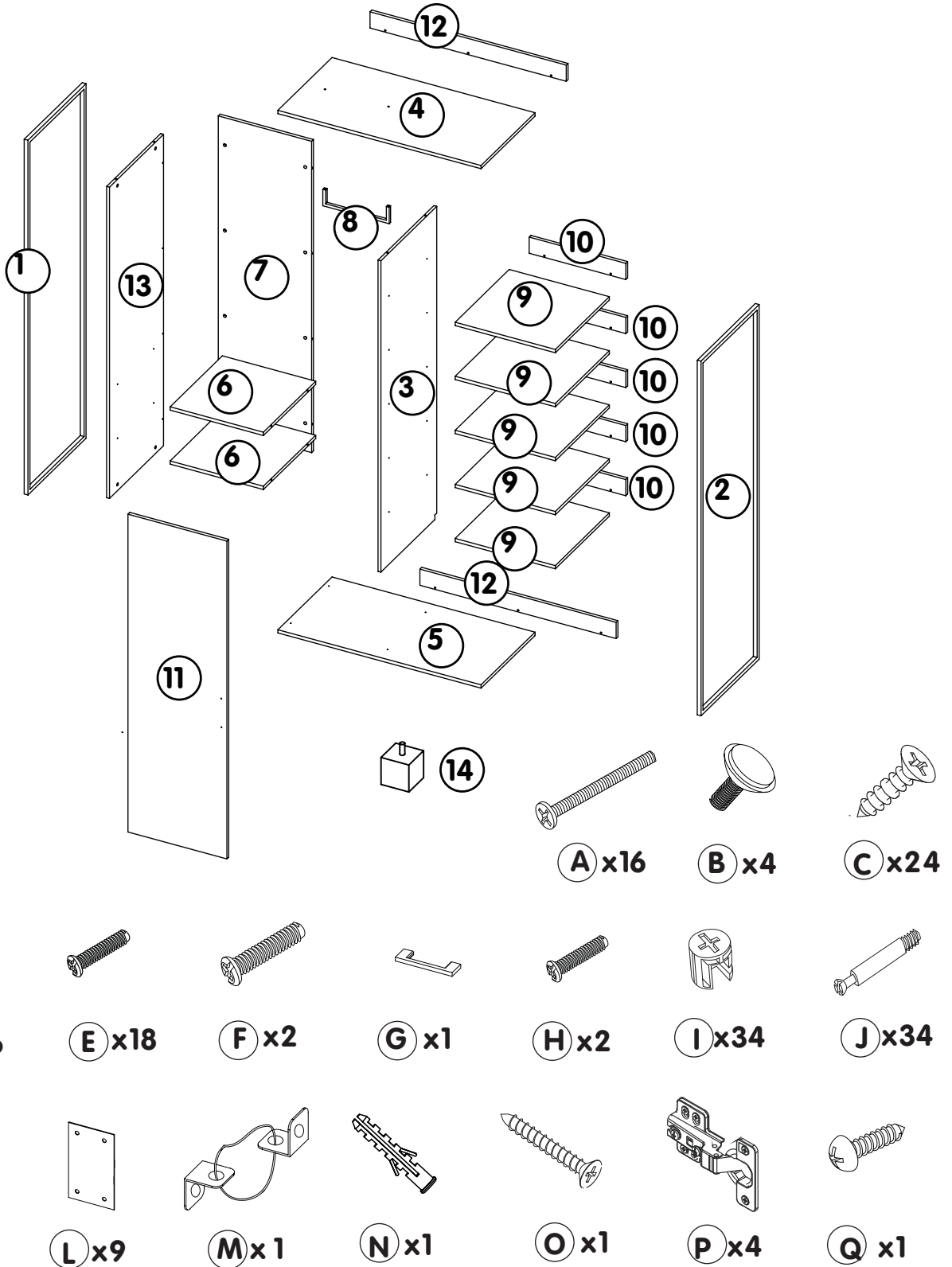

3.

Montage-
anleitung

Instructions de
montage

Istruzioni per
il montaggio

Assembling
instruction

1

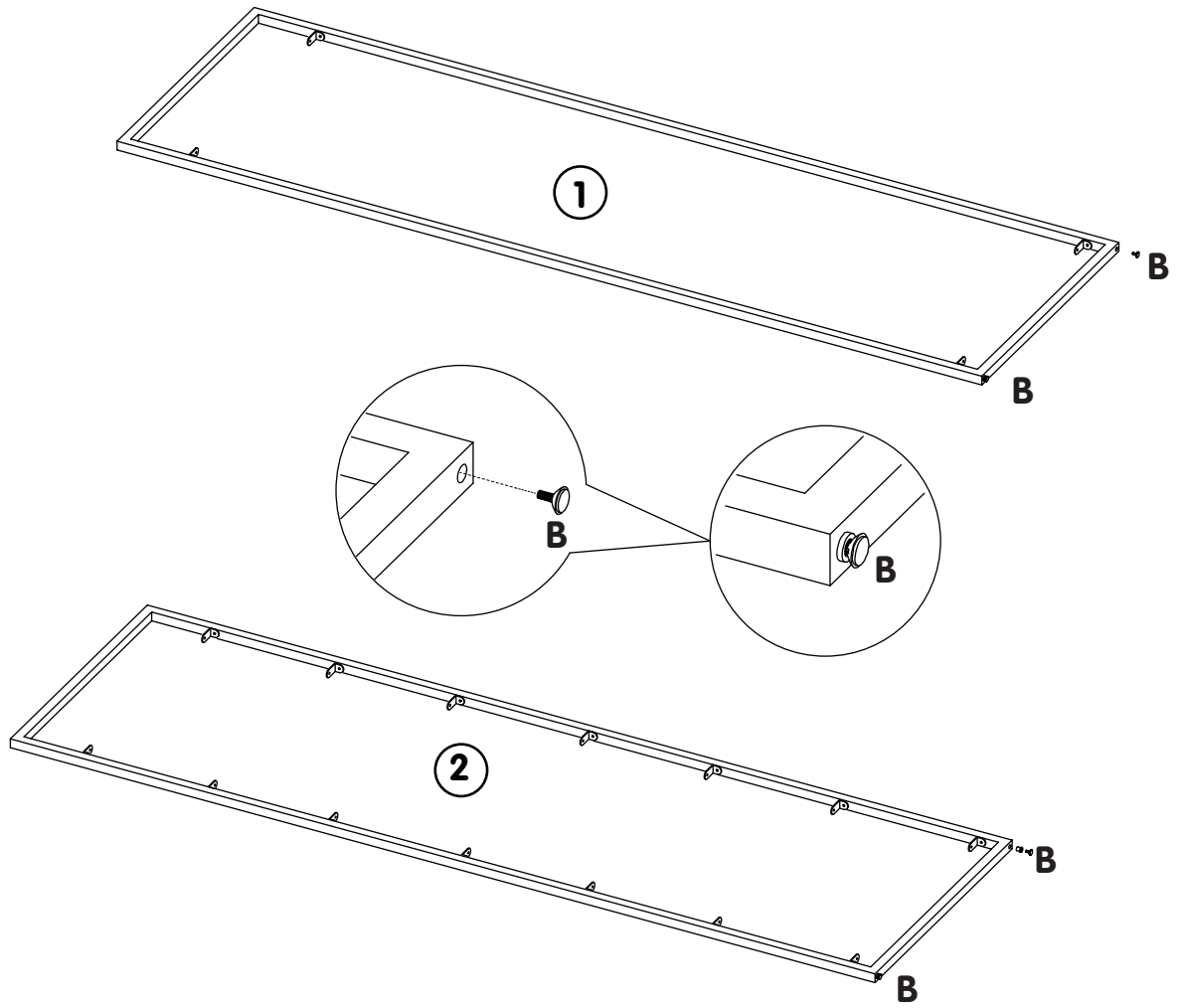

2

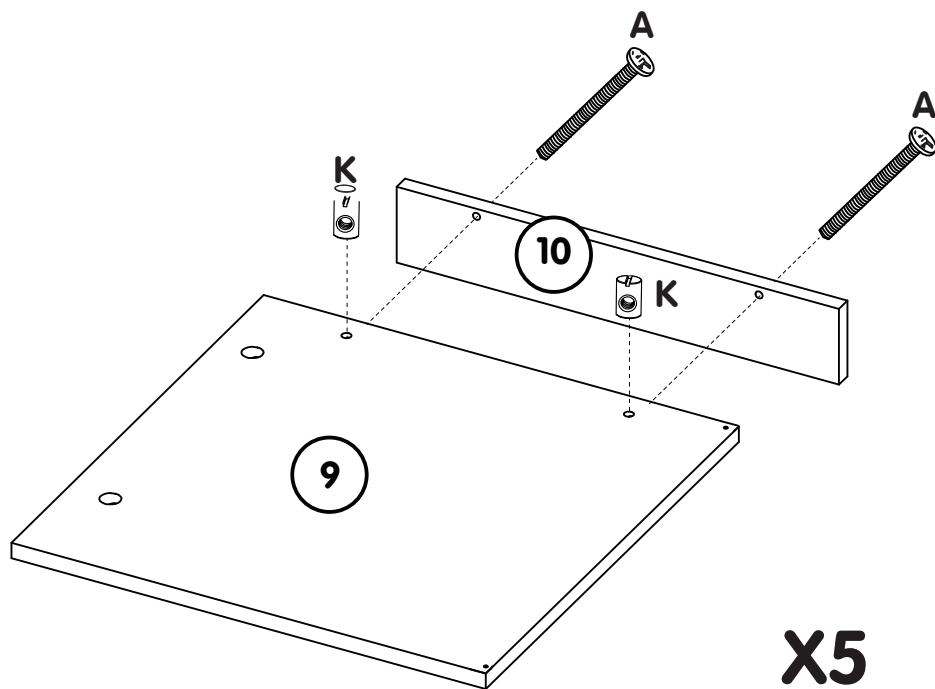

3.

Montage-
anleitung

Instructions de
montage

Istruzioni per
il montaggio

Assembling
instruction

3

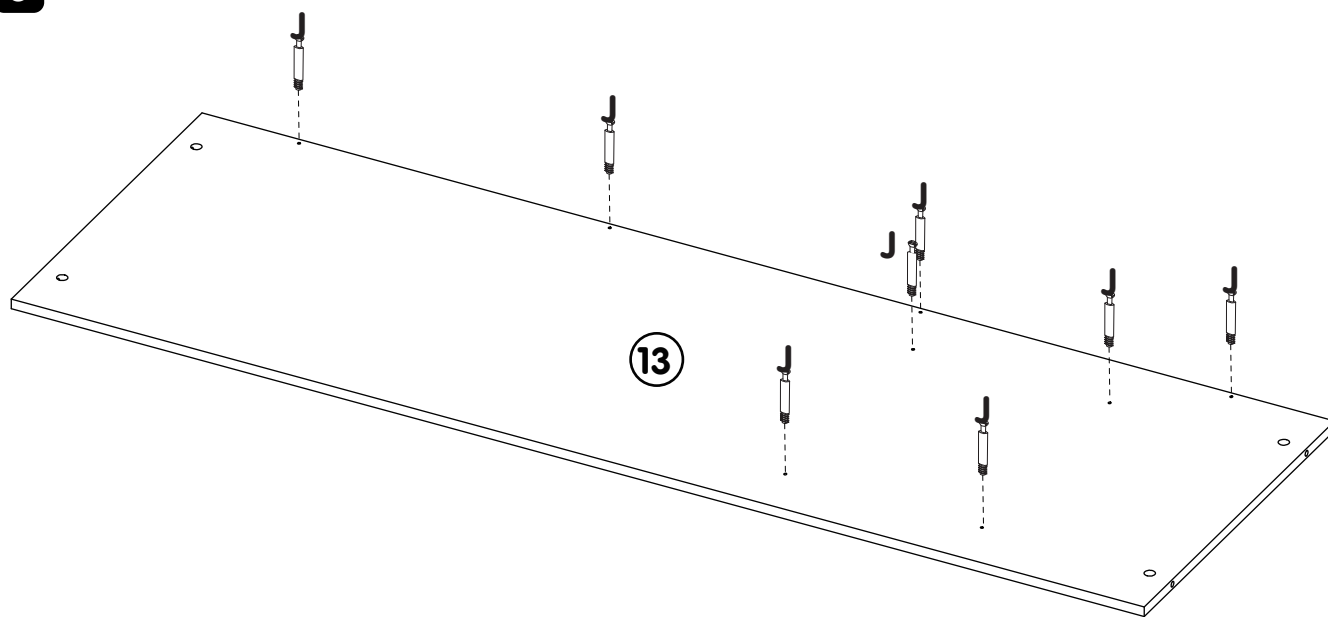

4

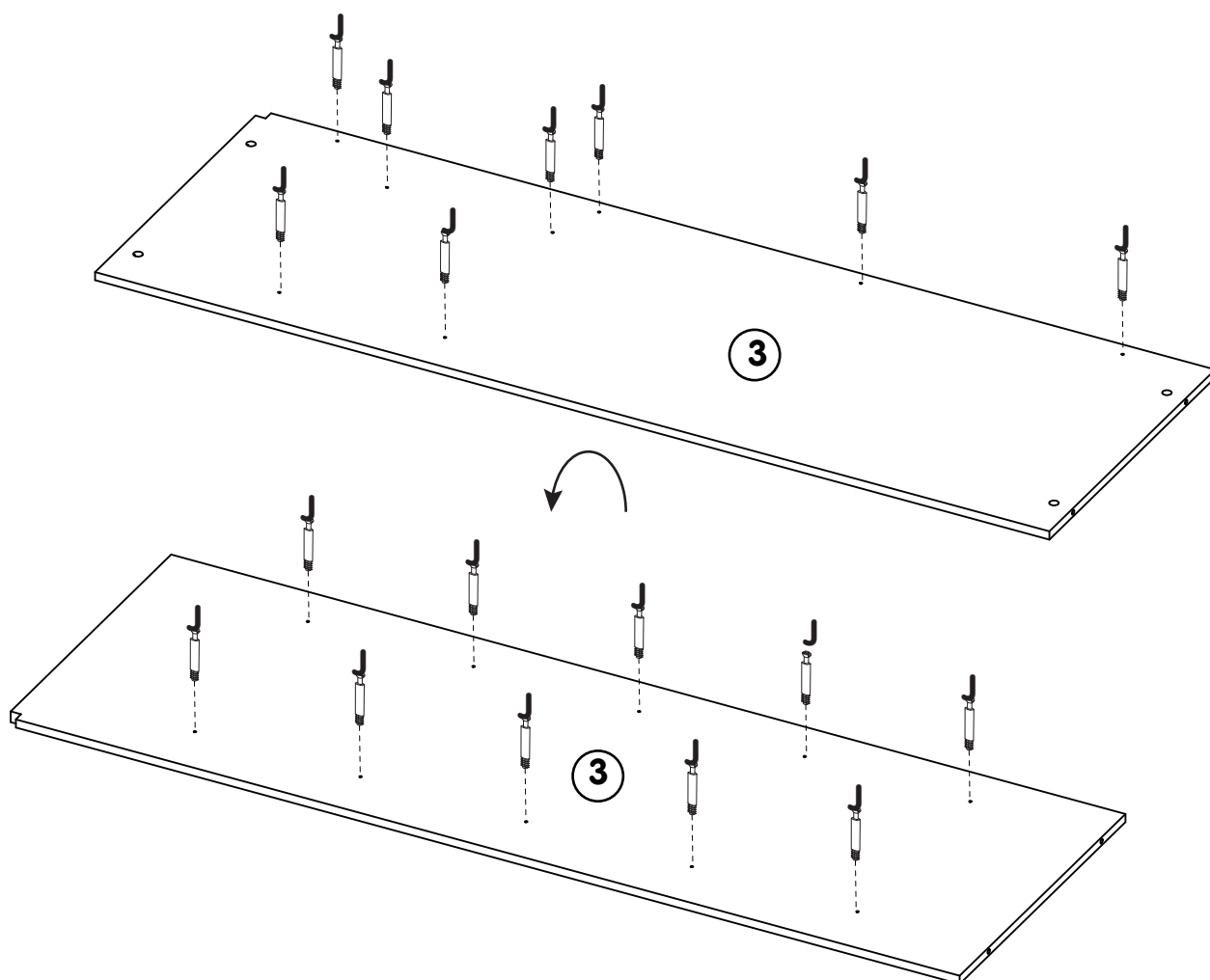

3.

Montage-
anleitung

Instructions de
montage

Istruzioni per
il montaggio

Assembling
instruction

5

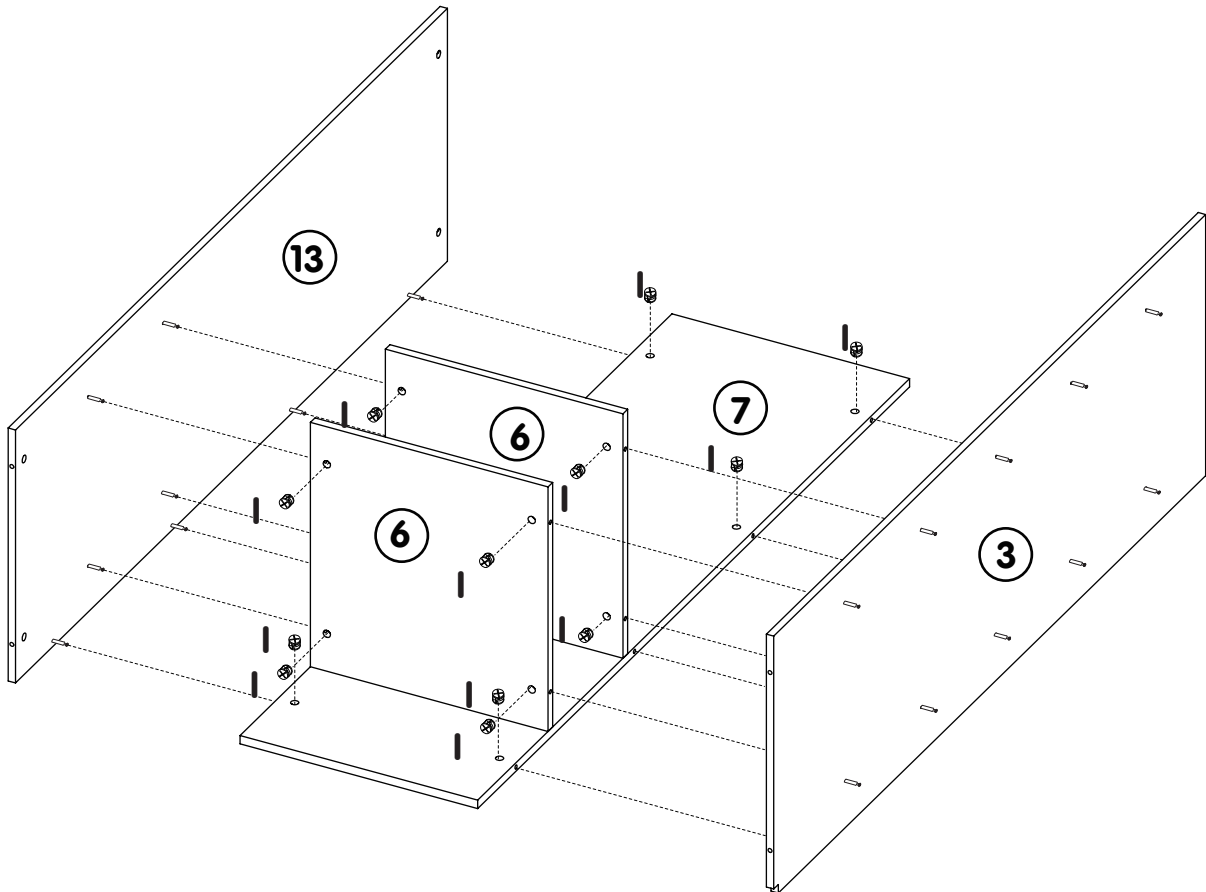

6

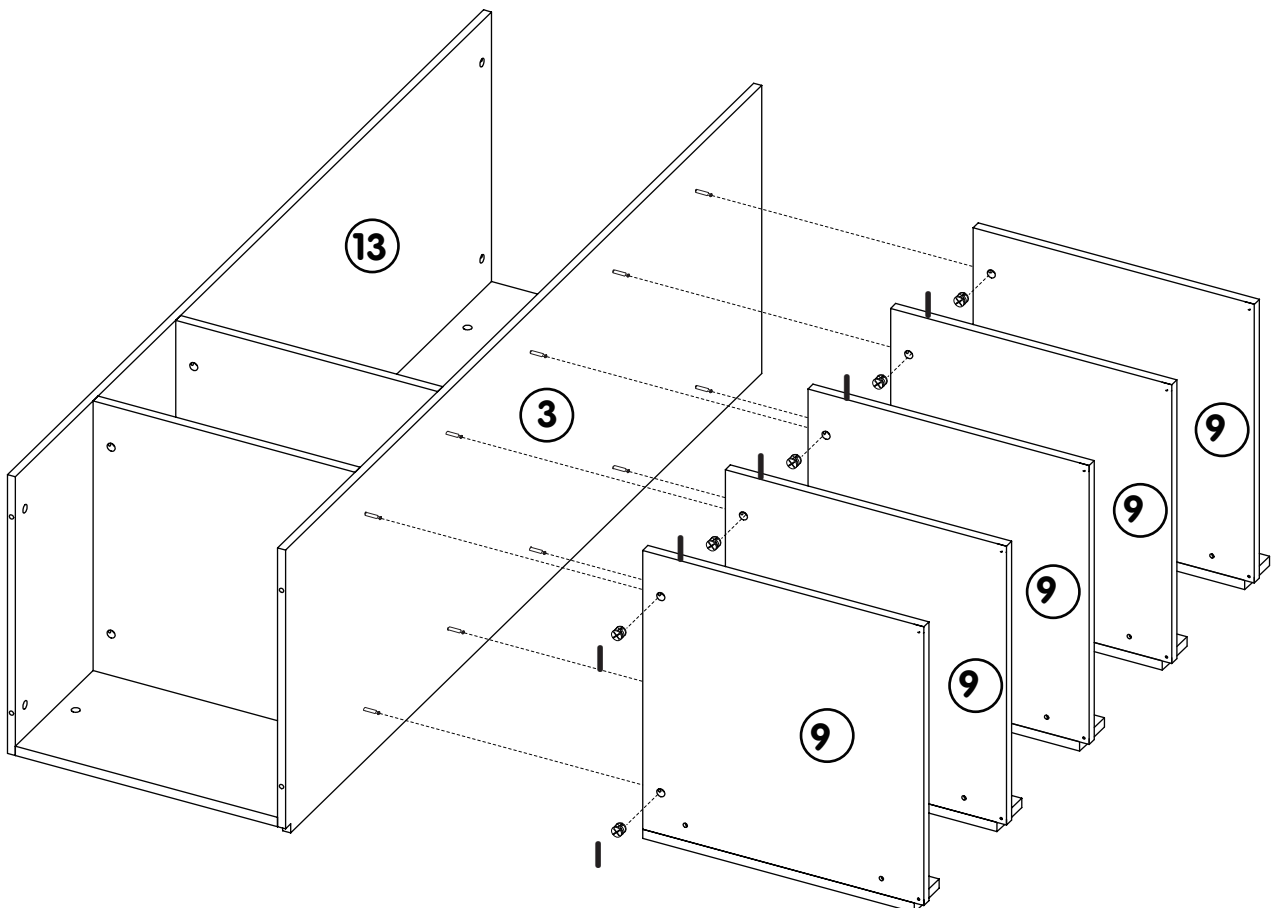

3.

Montage-
anleitung

Instructions de
montage

Istruzioni per
il montaggio

Assembling
instruction

7

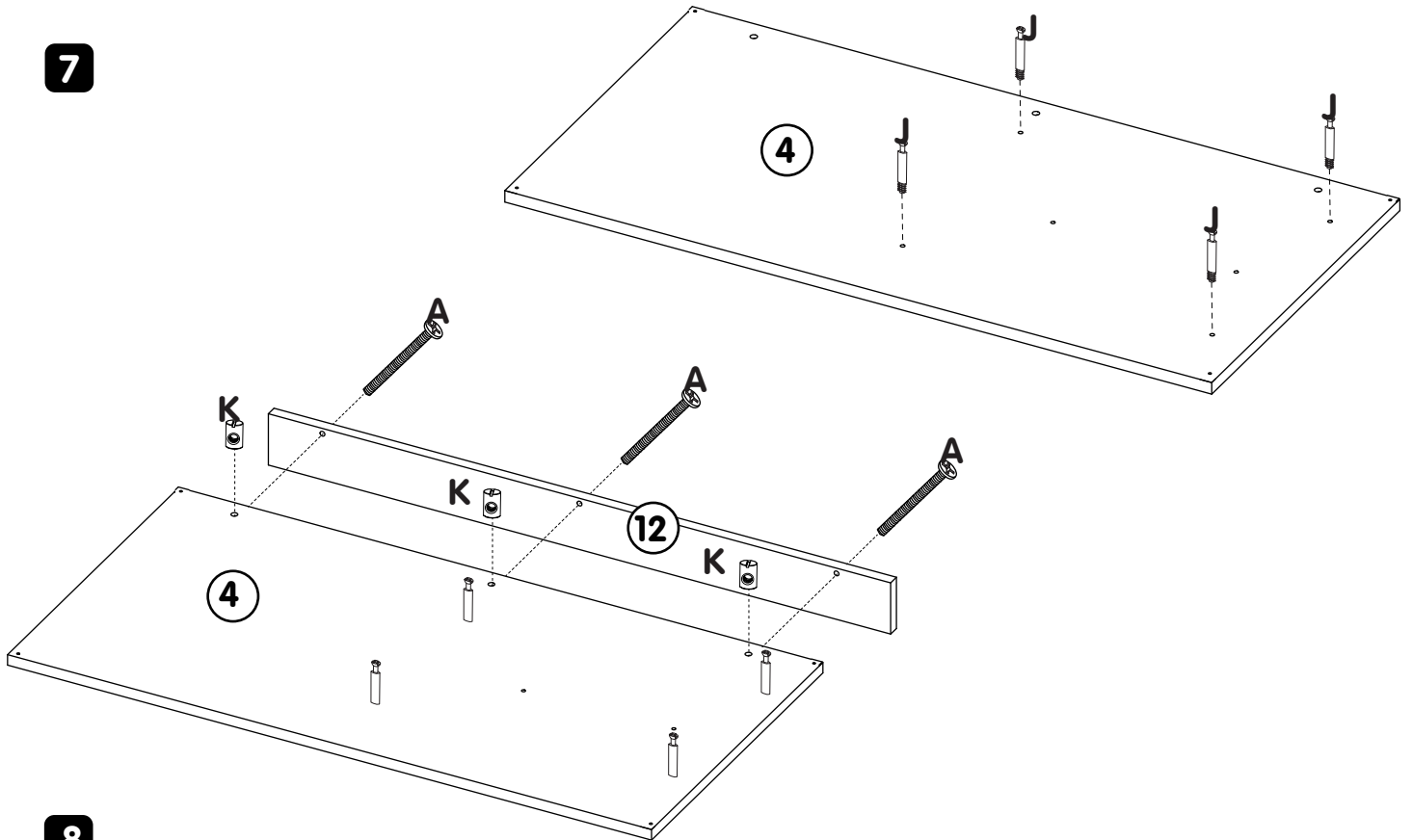

8

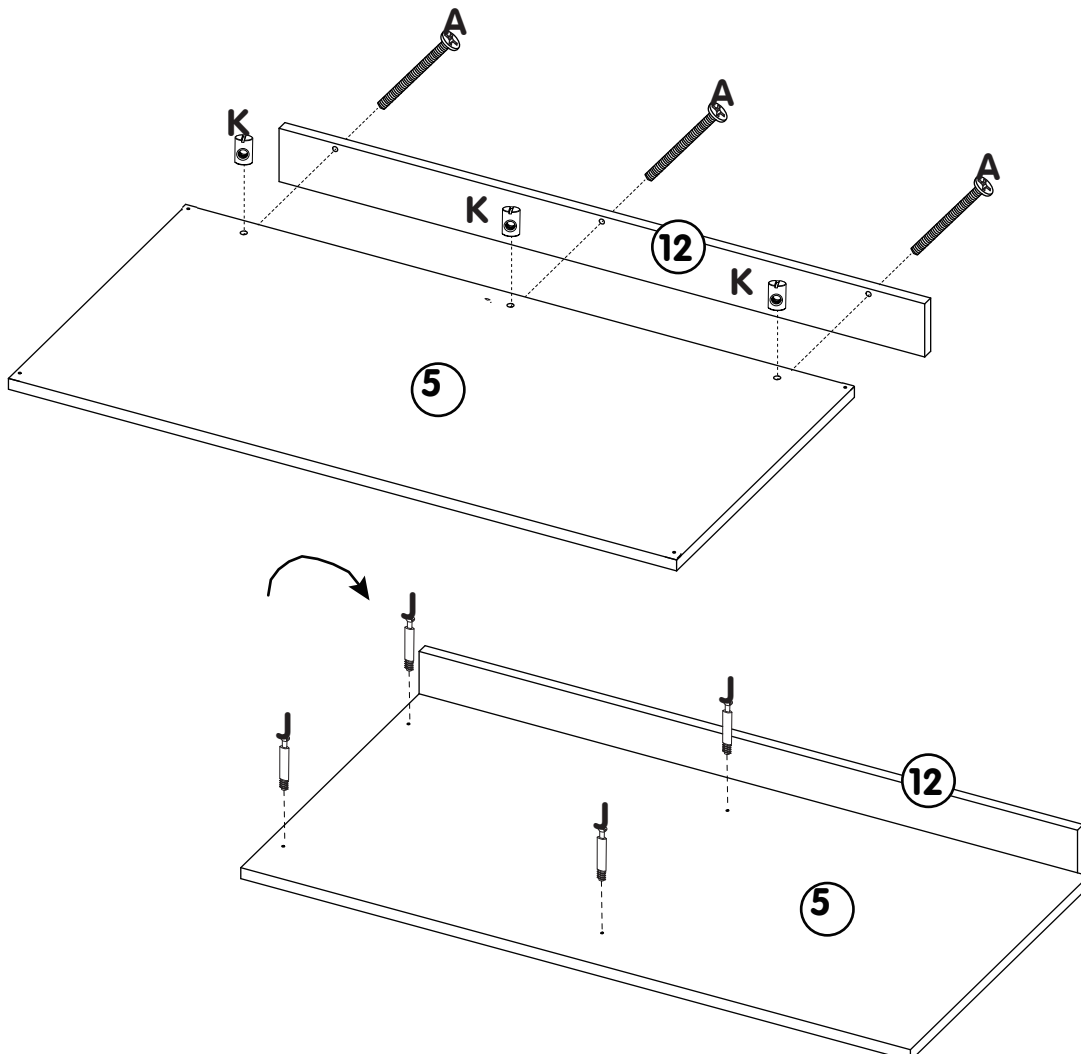

3.

Montage-
anleitung

Instructions de
montage

Istruzioni per
il montaggio

Assembling
instruction

9

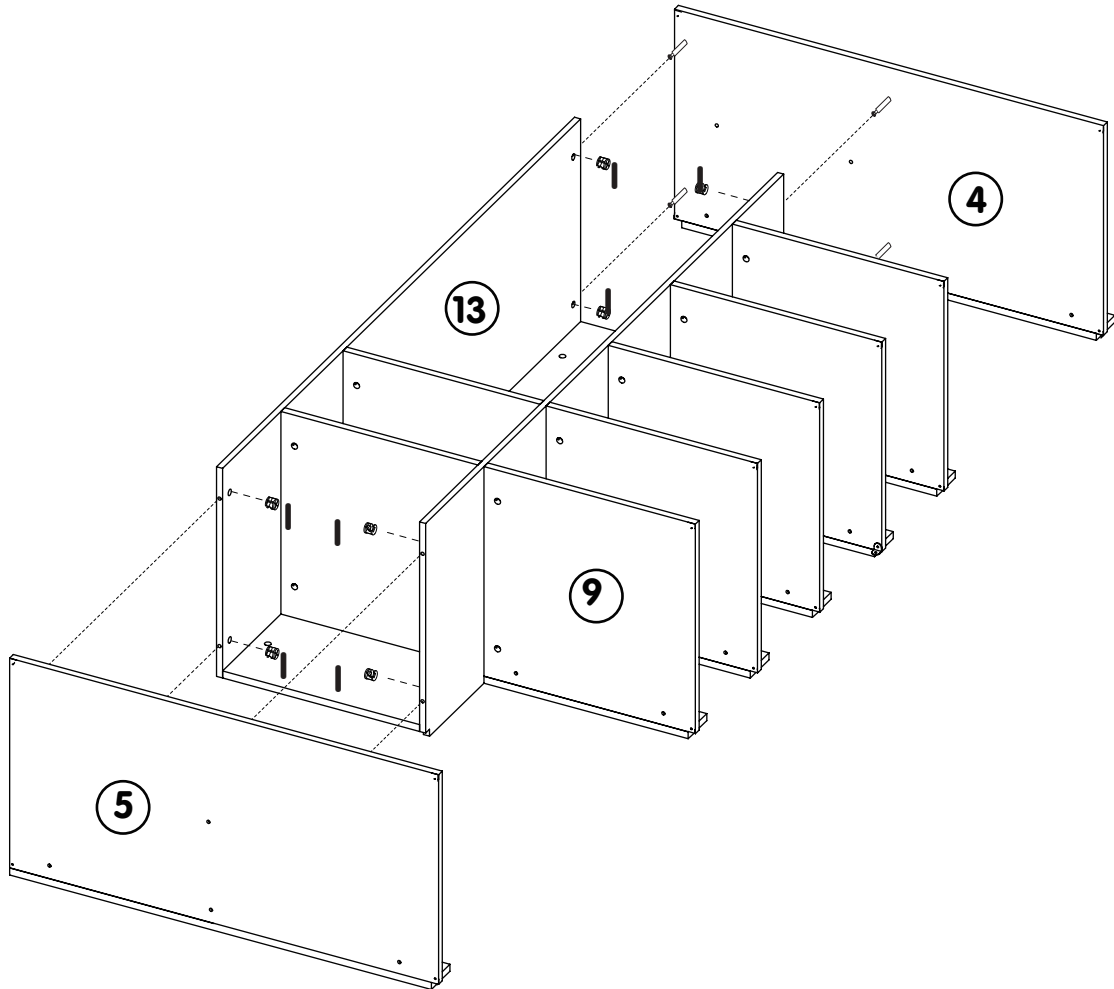

10

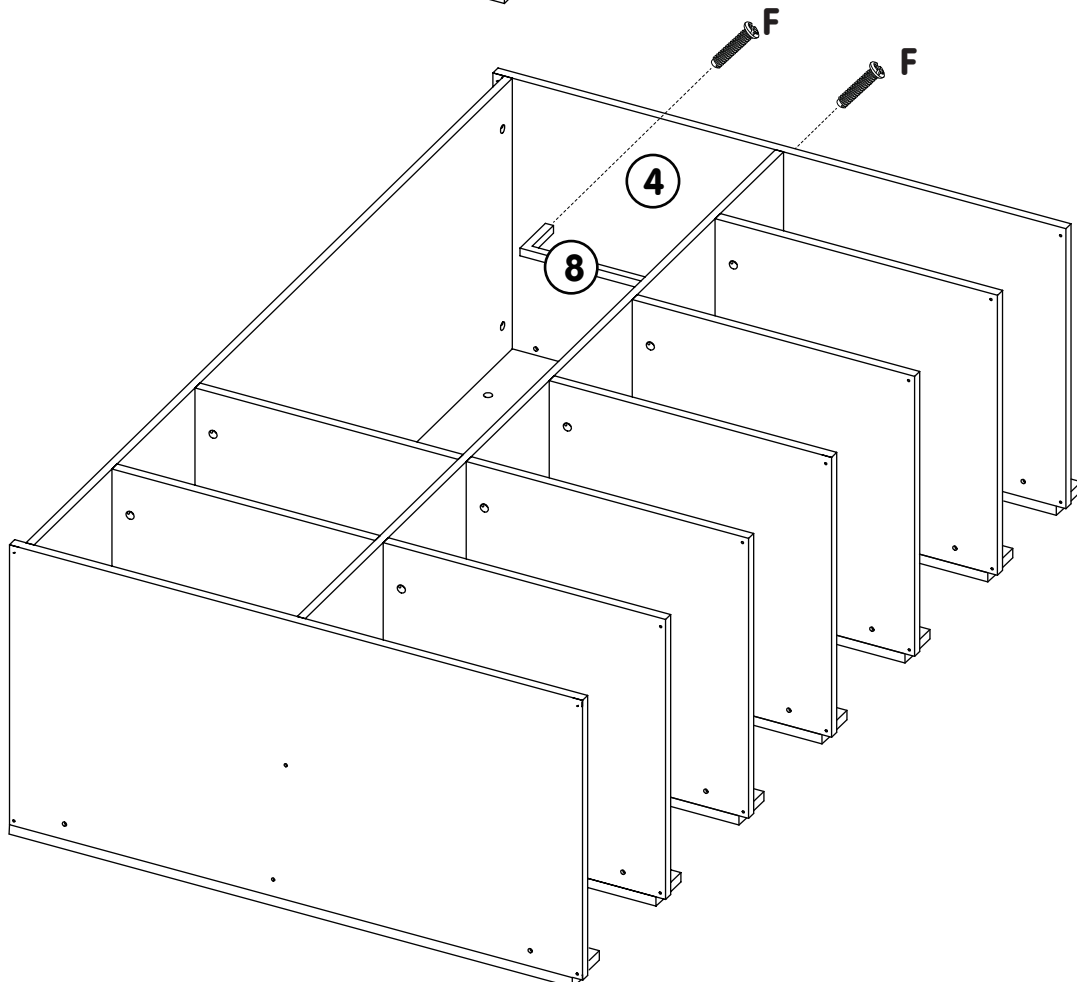

3.

Montage-
anleitung

Instructions de
montage

Istruzioni per
il montaggio

Assembling
instruction

11

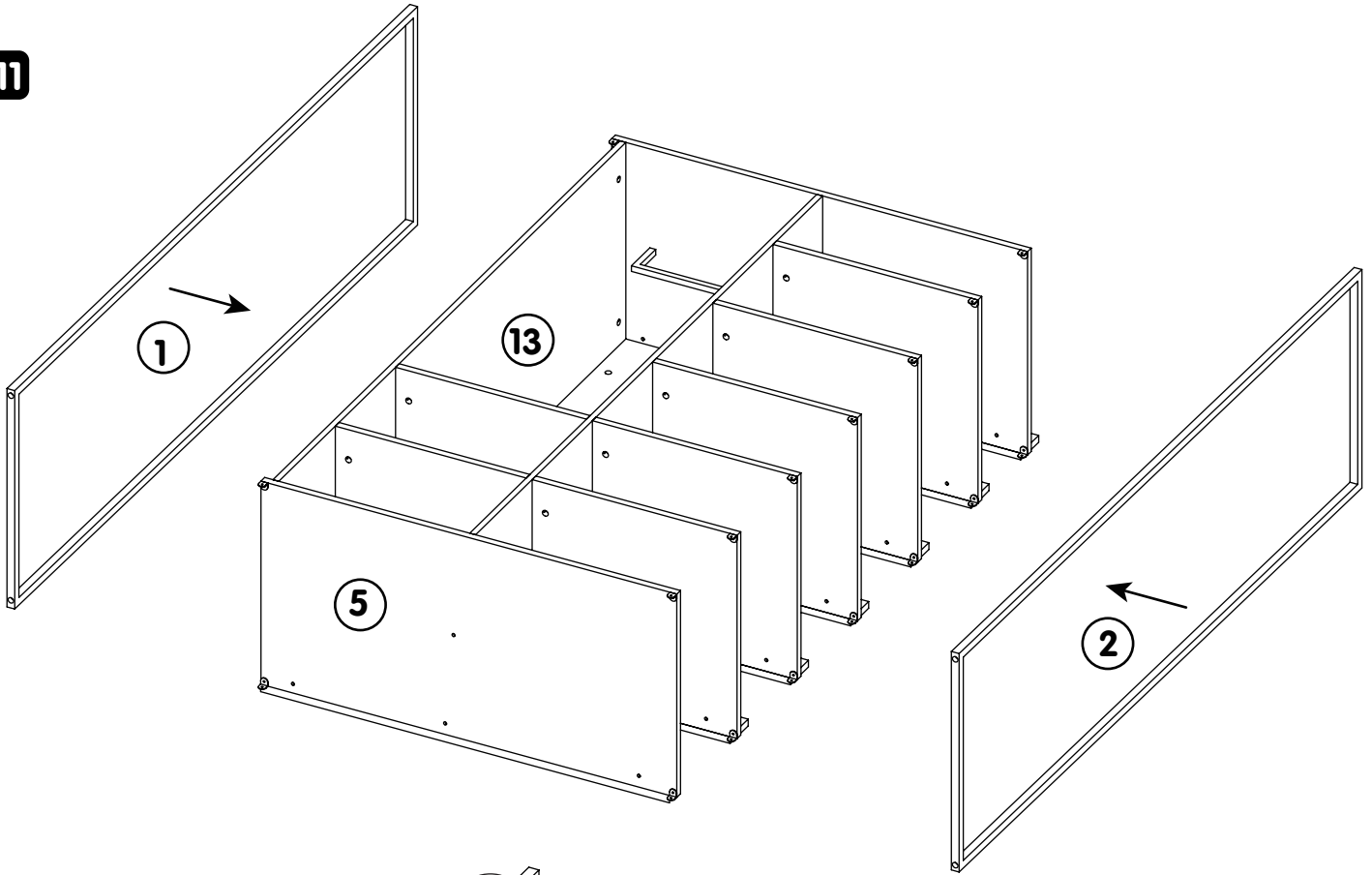

12

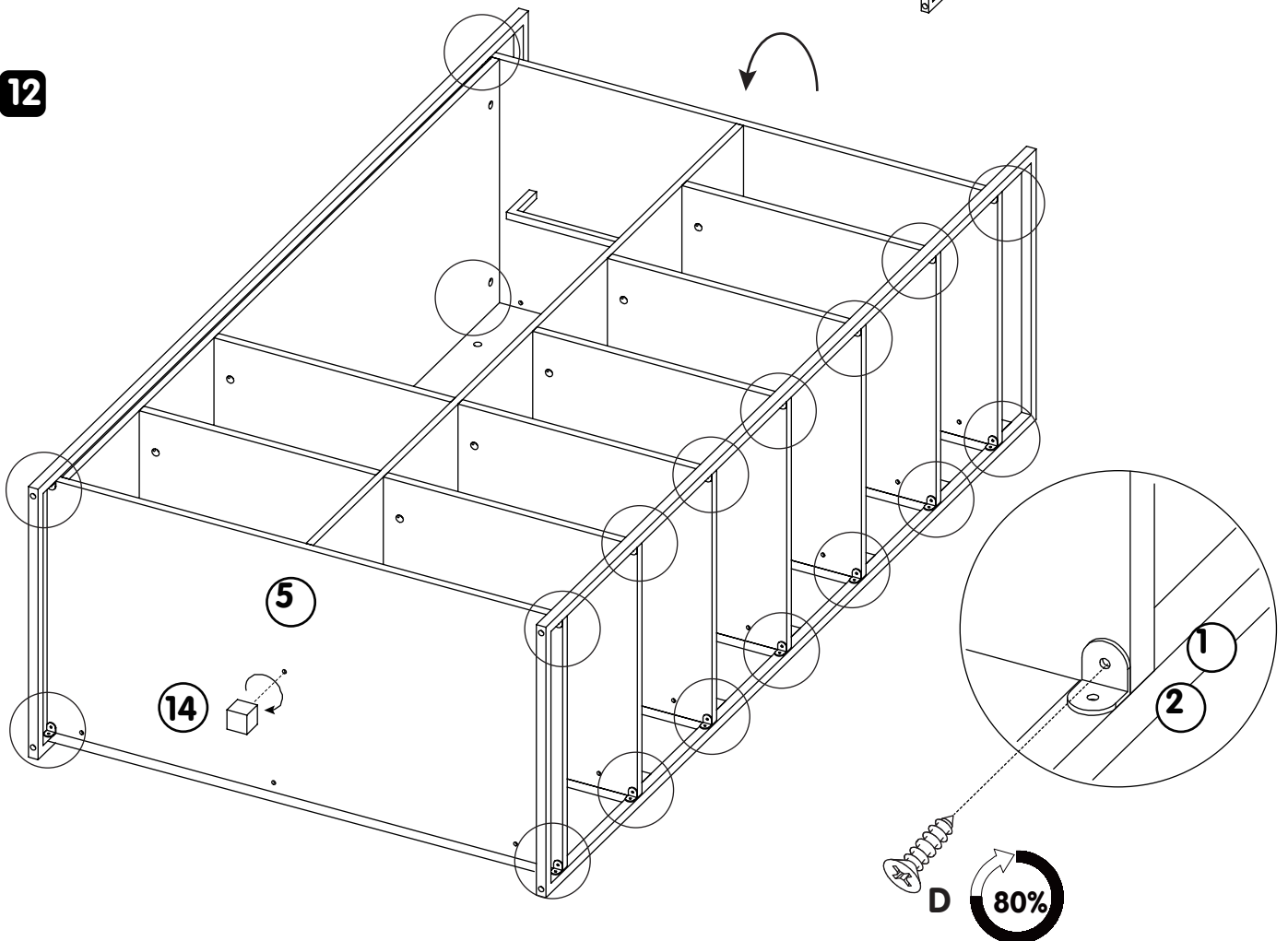

3.

Montage-
anleitung

Instructions de
montage

Istruzioni per
il montaggio

Assembling
instruction

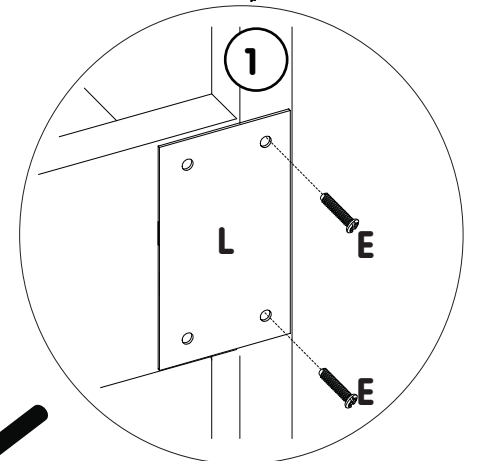
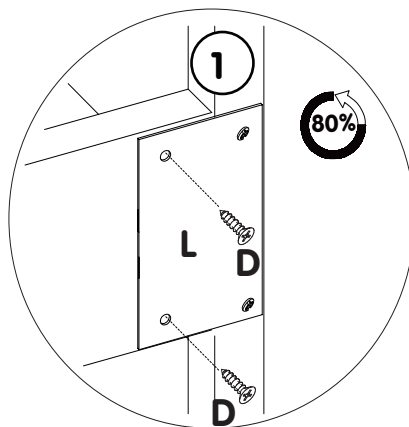
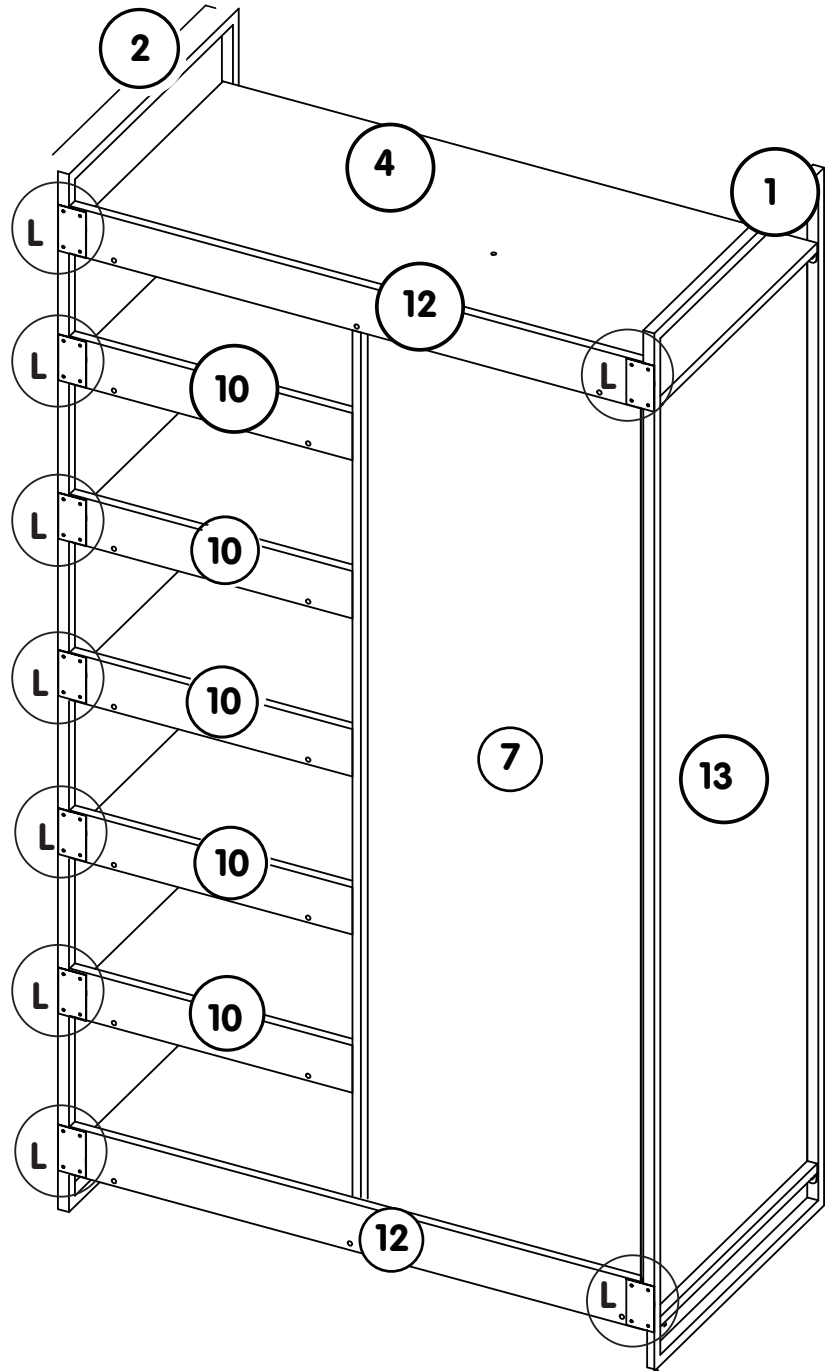
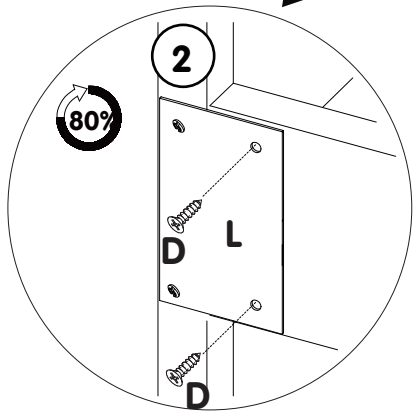
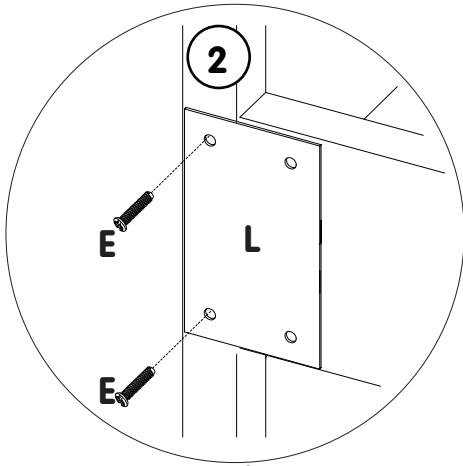

3.

Montage-
anleitung

Instructions de
montage

Istruzioni per
il montaggio

Assembling
instruction

14

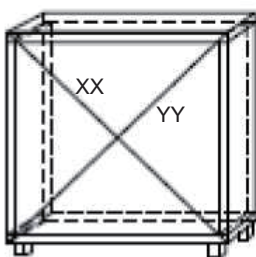
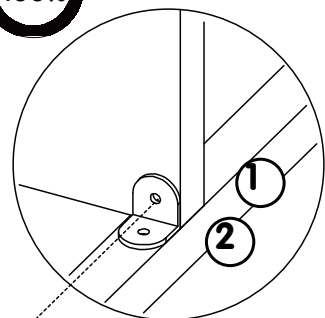
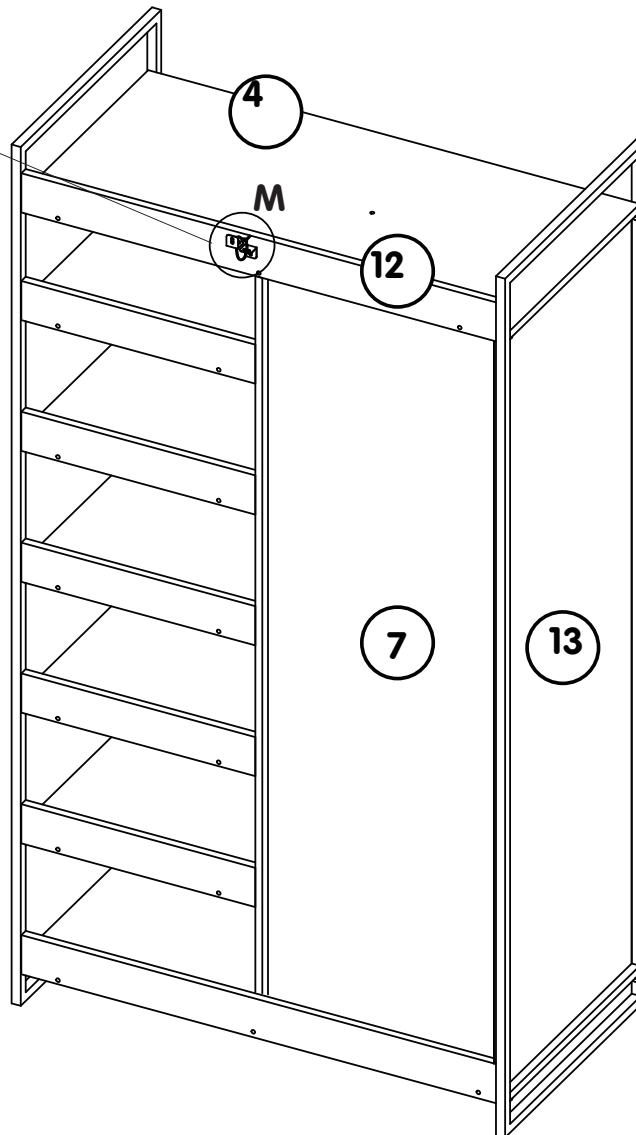
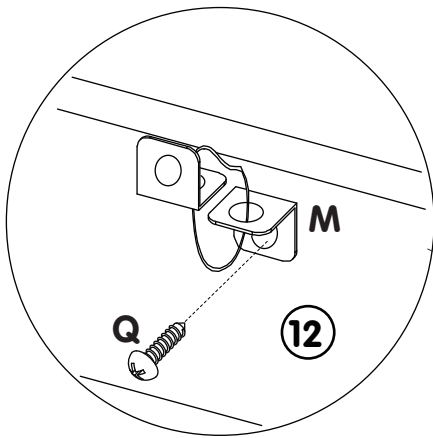

$XX=YY=90^\circ$

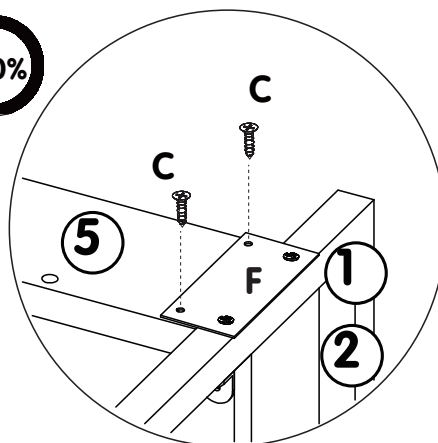

3.

Montage-
anleitung

Instructions de
montage

Istruzioni per
il montaggio

Assembling
instruction

15

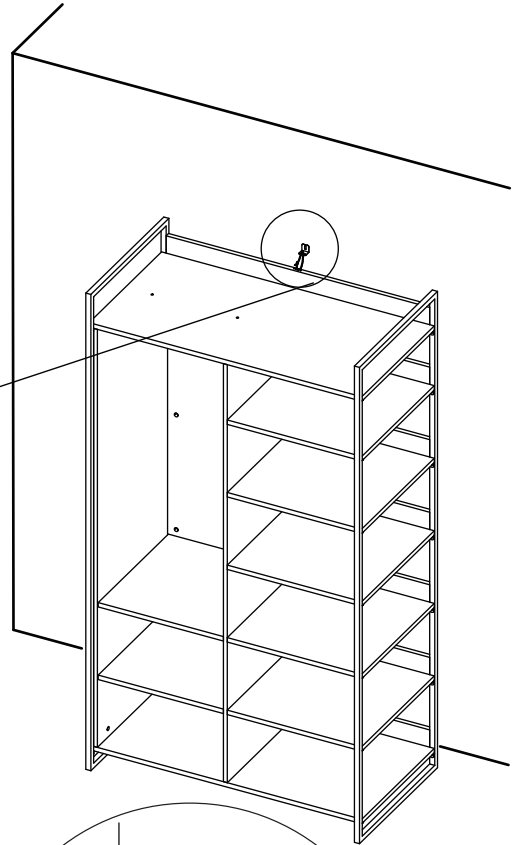
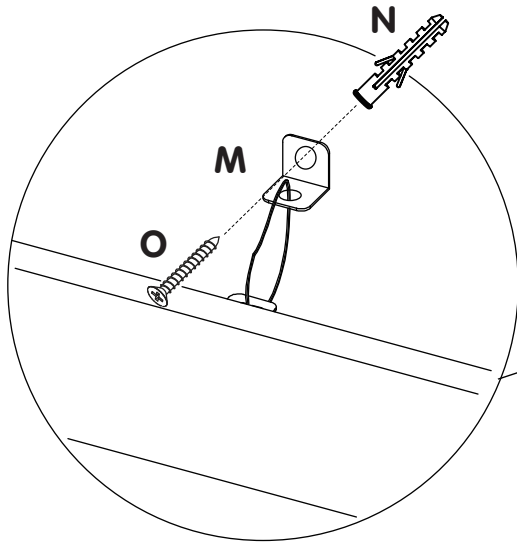

16

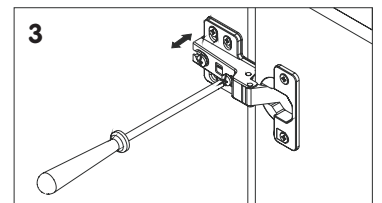
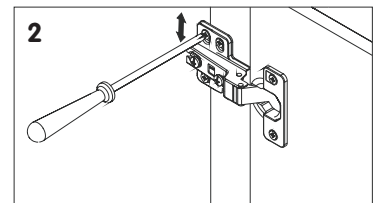
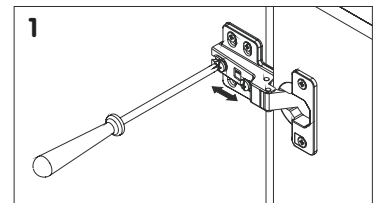
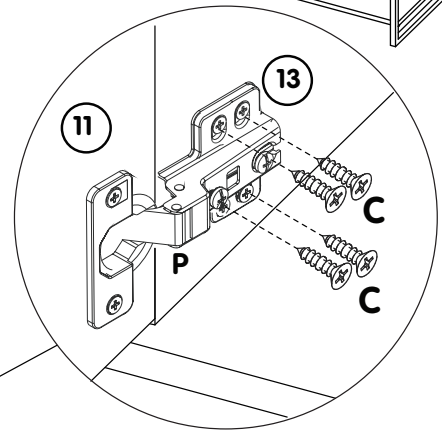
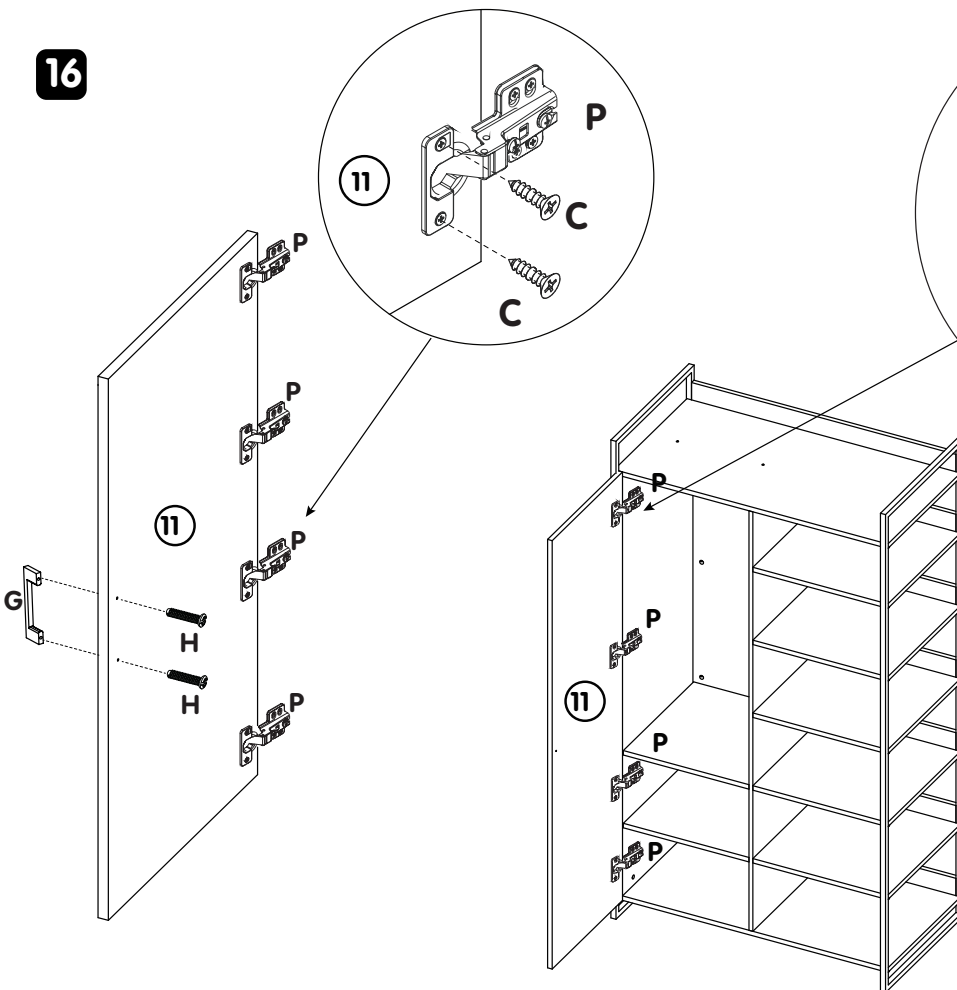

**Reinigung allgemein:**

Flecken immer sofort entfernen. Ein sauberes, weisses Tuch verwenden.



Sauberes Wasser verwenden. Lässt sich der Fleck so nicht entfernen, seifenhaltiges Wasser verwenden. Werden Reinigungsmittel verwendet, diese immer zuerst an einer nicht sichtbaren Stelle testen.



ACHTUNG Keine chemischen, scheuern- oder kratzenden Reinigungs-/Hilfsmittel verwenden.

Nettoyage en général:

Toujours éliminer immédiatement les taches. Utiliser un chiffon blanc, propre.

Utiliser une eau propre. Si la tache ne s'enlève pas, utiliser une eau savonneuse. Si un produit de nettoyage est utilisé, toujours l'essayer préalablement dans un endroit invisible.

ATTENTION Ne pas utiliser de produits ou moyens chimiques, agressifs ou abrasifs.

Pulizia generale:

rimuovere sempre subito le macchie. Utilizzare un panno bianco, pulito.

Utilizzare acqua pulita. Se la macchia non viene via, utilizzare dell'acqua con sapone. Se si utilizzano dei detergenti, provarli sempre prima in un punto non visibile.

ATTENZIONE Non utilizzare detergenti chimici o prodotti/materiali abrasivi.

General cleaning instructions:

Always remove stains immediately. Use a clean, white cloth.

Use clean water. If the stain does not come out, use soapy water. If you use cleaning detergents, always test them first in a concealed spot.

CAUTION Do not use any chemical or abrasive cleaning detergents or cloths/tools.

**Möbelpflege:**

Lackiertes Holz nur mit einem leicht feuchten Tuch abwischen.



Geölte Holzoberflächen je nach Gebrauch, von Zeit zu Zeit (z.B. vierteljährlich) erneut ölen.

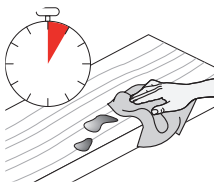

Feuchtigkeitsrückstände auf geölten und gewachsen Flächen müssen sofort entfernt werden. Ansonsten kommt es zu Fleckenbildung.



ACHTUNG Keine chemischen, scheuern- oder kratzenden Reinigungs-/Hilfsmittel verwenden.

Entretien des meubles:

Essuyer le bois vernis uniquement avec un chiffon légèrement humide.

Pour les surfaces en bois huilé, appliquer de temps à autre (p.ex. tous les 3 mois) et en fonction de l'utilisation une huile pour bois.

Les restes d'humidité sur les surfaces huilées et cirées doivent être immédiatement enlevés. Risque de formation de taches.

ATTENTION Ne pas utiliser de produits ou moyens chimiques, agressifs ou abrasifs.

Cura dei mobili:

pulire il legno laccato utilizzando soltanto un panno leggermente umido.

Le superfici di legno oliate di tanto in tanto, a seconda del loro utilizzo (ad es. ogni tre mesi), devono essere nuovamente trattate con olio.

È necessario eliminare subito i residui di umidità dalle superfici oliate e cerate, altrimenti c'è il rischio che si formino delle macchie.

ATTENZIONE Non utilizzare detergenti chimici o prodotti/materiali abrasivi.

Furniture care:

Only wipe varnished wood with a slightly damp cloth.

Re-oil oiled wooden surfaces from time to time (e.g. every three months) depending on use.

To prevent stains, immediately wipe off any wet spots on oiled and waxed surfaces.

CAUTION Do not use any chemical or abrasive cleaning detergents or cloths/tools.

**Schrauben:**

Für einwandfreie, zuverlässige Funktion, Schrauben regelmäßig nachziehen (z.B. vierteljährlich).

Vis:

Resserrer régulièrement les vis (p.ex. tous les 3 mois) pour assurer un fonctionnement sûr et correct.

Viti:

per garantire un funzionamento corretto e sicuro stringere regolarmente le viti (ad es. ogni tre mesi).

Screws:

To keep your furniture in good working order, tighten the screws regularly (e.g. every three months).

Scharniere:

Für einwandfreie, zuverlässige Funktion Topfbänder und Scharniere regelmäßig kontrollieren und falls nötig justieren (z.B. vierteljährlich).

Charnières:

Pour un fonctionnement sûr et correct, les paumelles et charnières doivent être régulièrement contrôlées et le cas échéant réajustées (p.ex. tous les 3 mois).

Cerniere:

per un funzionamento corretto e sicuro controllare regolarmente le cerniere a tazza e le cerniere in generale e se necessario regolarle (ad es. ogni tre mesi).

Hinges:

To ensure all the hinges and concealed hinges continue to work smoothly, check them regularly and adjust them if necessary (e.g. every three months).

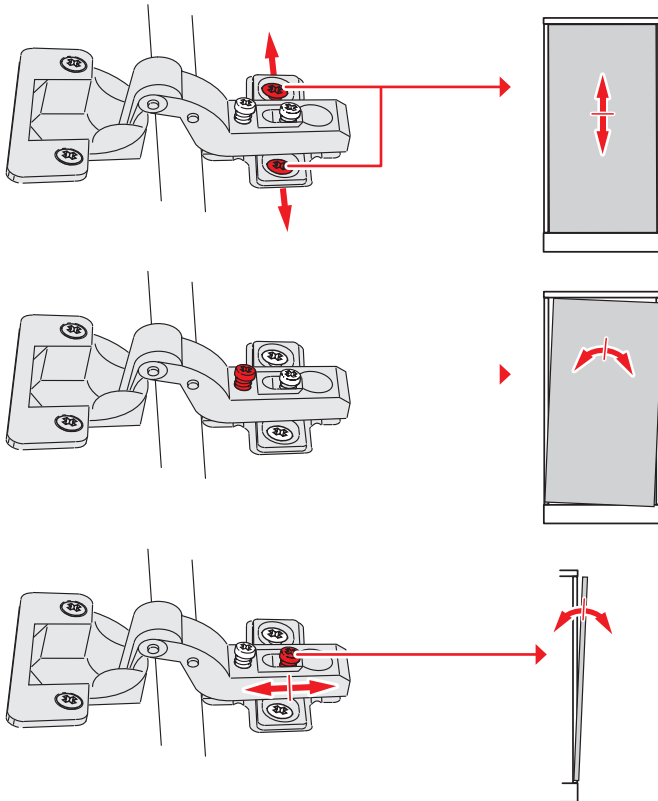

6.

Entsorgung**Élimination****Smaltimento****Disposal****Entsorgungsservice:**

Micasa bietet Ihnen einen Entsorgungsservice an. Weitere Informationen erhalten Sie unter www.micasa.ch

Entsorgung:
Nicht mehr verwendete Möbel der fachgerechten Entsorgung übergeben. Wenden Sie sich an Ihre lokale Entsorgungsstelle.

Service d'élimination:

Micasa vous propose un service d'élimination. Vous trouverez des informations supplémentaires sur www.micasa.ch

Élimination:
Veuillez remettre les meubles qui ne sont plus utilisés à une entreprise d'élimination. Adressez-vous à votre centre de collecte local.

Servizio di smaltimento:

Micasa vi offre un servizio di smaltimento. Ulteriori informazioni sono disponibili su www.micasa.ch

Smaltimento:
i mobili dismessi devono essere conferiti presso i centri di raccolta rifiuti per il loro corretto smaltimento. Rivolgersi presso il centro di raccolta locale.

Disposal service:

Micasa offers a disposal service. For more information visit www.micasa.ch

Disposal:
To correctly dispose of furniture that is no longer used, contact your local recycling centre.

7.

Kontakt / Service**Contact / service****Contatto / servizio****Contact / service**

Fragen / Anregungen:
Wir sind gerne für Sie erreichbar:
Montag bis Freitag
08.00 bis 18.00 Uhr
Samstag
08.30 bis 16.30 Uhr
Tel. 0800 840 848

Questions / suggestions:
Nous sommes à votre disposition:
Lundi - vendredi
08h00 à 18h00
Samedi
08h30 à 16h30
Tél. 0800 840 848

Domande / suggerimenti:
siamo a vostra disposizione:
lunedì - venerdì
dalle 08.00 alle 18.00
sabato
dalle 08.30 alle 16.30
Tel. 0800 840 848

Questions / Suggestions
Please contact us. Our opening times are:
Monday - Friday
8.00 to 18.00
Saturday
8.30 to 16.30
Phone 0800 840 848



Ersatzteile:
Erhalten Sie direkt im Online-Shop von Migros-Service:

www.migros-service.ch

Pièces de rechange:
Vous les obtenez directement dans le magasin en ligne de Migros-Service:

www.migros-service.ch

Pezzi di ricambio:
sono disponibili direttamente sull'online-shop di Migros-Service:

www.migros-service.ch

Spare parts:
Available directly from the Migros-Service online shop:

www.migros-service.ch