

---

**Wichtig:**  
Vor Gebrauch sorgfältig durchlesen/  
Montageanleitung für späteres Nachlesen aufbewahren

**Important:**  
Lisez attentivement/  
conserver les instructions d'installation pour référence future avant utilisation

**Importante:**  
lettura/conservare Istruzioni per l'installazione per riferimento futuro accuratamente prima dell'uso

**Important:**  
Read carefully before assembling/keep and store Instruction for reference

# TILL

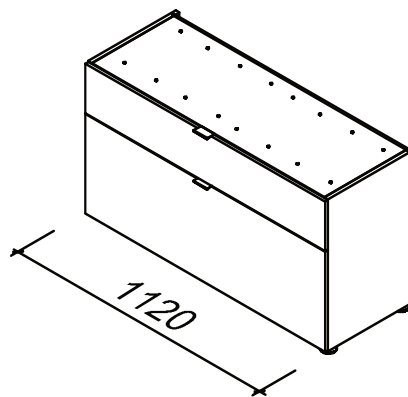
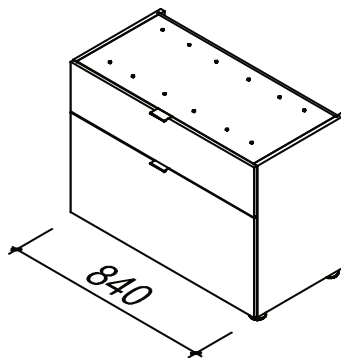
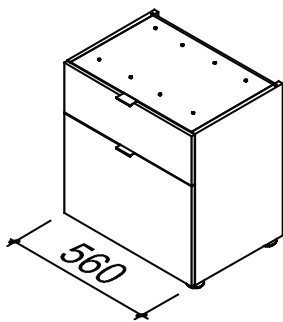



## Warnhinweise

### Bestimmungsgemässer Gebrauch:

Bitte achten Sie darauf, dass Ihre Möbel nur Ihrem Zweck gemäss verwendet werden. Für eine dauerhafte Funktionsfähigkeit ist eine sachgerechte Nutzung und regelmässige Unterhaltungspflege sehr wichtig.

## Mises en garde

### Utilisation conforme:

Veillez vous assurer que vos meubles sont utilisés uniquement pour leur usage prévu. Un entretien régulier et une utilisation conforme sont essentiels pour assurer un fonctionnement durable.

## Avvertenze

### Utilizzo per lo scopo previsto:

assicuratevi che i vostri mobili siano utilizzati solo per lo scopo per cui sono stati realizzati. Per garantire il loro funzionamento nel tempo è importante utilizzarli correttamente e sottoporli regolarmente a cure manutentive.

## Warning notice

### Intended use:

Please make sure that you only use your furniture for the purpose it was designed for. Correct use and regular maintenance are essential for ensuring your furniture remains in working order for the long-term.

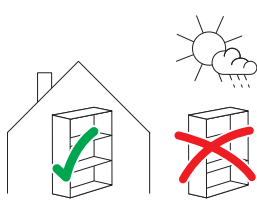

### Anwendung:

Das von Ihnen erworbene Behältnismöbel eignet sich für den allgemeinen, privaten Wohnbereich. Es ist nicht für den Nass-, Aussen- oder gewerblichen Bereich geeignet.

### Usage:

Le meuble de rangement que vous avez acheté convient pour l'habitat privé en général. Il ne convient pas pour l'extérieur, les milieux humides ou le domaine commercial.

### Impiego:

il mobile contenitore acquistato è adatto per un utilizzo in generale, in ambiente domestico. Non è adatto per gli esterni, per l'esposizione alla pioggia o per ambienti commerciali.

### Area of use:

The storage furniture you have purchased is suitable for use in general private living quarters. It is not suitable for areas that are wet, outside or used for commercial purposes.

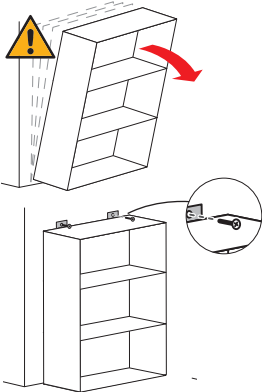

### VORSICHT, dieses Möbel kann Kippen.

Um dies zu verhindern, muss es mit Kippsicherung(en) an der Wand / Decke befestigt werden. Die Befestigung ist abhängig von der Wand-/Deckenbeschaffenheit (z.B. Beton/Gips/Backstein/Holz) und muss von einem Fachmann ausgeführt werden.

### PRÉCAUTION, ce meuble peut basculer.

Pour empêcher cela, il doit être fixé au mur/plafond avec une sécurité anti-basculement. La fixation dépend de la nature du mur/plafond (p.ex. béton/plâtre/brique/bois) et doit être réalisée par un spécialiste.

### PRECAUZIONE, questo mobile può ribaltarsi.

Per evitare questo, deve essere adeguatamente fissato alla parete o al soffitto. Il tipo di fissaggio dipende dalle caratteristiche della parete o del soffitto (ad es. cemento/gesso/mattone/legno) e il fissaggio deve essere eseguito da un esperto.

### PRECAUTION, this piece of furniture can tip over.

To prevent this it must be secured to the wall or ceiling with brackets. The type of bracket depends on the quality of the wall and/or ceiling (e.g. concrete, plaster, brick, wood) and must be mounted by a specialist.

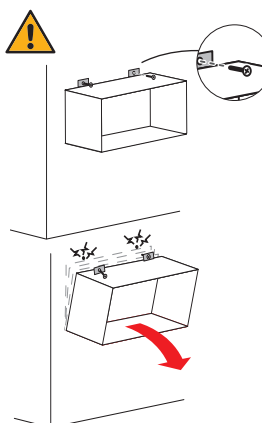

### VORSICHT, dieses Möbel kann runterfallen:

Um dies zu verhindern, muss es richtig an der Wand / Decke befestigt werden. Die Befestigung ist abhängig von der Wand-/Deckenbeschaffenheit (z.B. Beton/Gips/Backstein/Holz) und muss von einem Fachmann ausgeführt werden.

### PRÉCAUTION, ce meuble peut tomber:

Pour empêcher cela, il doit être fixé correctement au mur/plafond. La fixation dépend de la nature du mur/plafond (p.ex. béton/plâtre/brique/bois) et doit être réalisée par un spécialiste.

### PRECAUZIONE, questo mobile può cadere:

per evitare questo, deve essere adeguatamente fissato alla parete o al soffitto. Il tipo di fissaggio dipende dalle caratteristiche della parete o del soffitto (ad es. cemento/gesso/mattone/legno) e il fissaggio deve essere eseguito da un esperto.

### PRECAUTION, this piece of furniture can fall down:

To prevent this, it must be secured properly to the wall or ceiling. The type of bracket depends on the quality of the wall and/or ceiling (e.g. concrete, plaster, brick, wood) and must be mounted by a specialist.

**Warnhinweise****Mises en garde****Avvertenze****Warning notice**

**WARNUNG**  
**Verschluck- und Erstickungsgefahr:**  
Kleinteile und Verpackungsmaterial können verschluckt werden.

**AVERTISSEMENT**  
**Risque d'ingestion et d'étouffement:**  
Les petites pièces et le matériel d'emballage peuvent être avalés.

**AVVERTENZA**  
**Pericolo di ingestione e soffocamento:**  
piccole parti e materiale di imballaggio possono essere ingerite.

**WARNING**  
**Risk of swallowing and choking:**  
Small parts and packaging material may be swallowed.



**WARNUNG!** Tüten und Folien sind kein Spielzeug! Bitte von Babys und Kleinkindern fernhalten! Nicht über den Kopf ziehen;  
Erstickungsgefahr!

**AVERTISSEMENT!**  
Les sacs et films ne sont pas des jouets! Veuillez les tenir hors de portée des bébés et jeunes enfants! Ne pas mettre sur la tête, risque d'étouffement!

**AVVERTENZA!** Sacchetti e pellicole non sono un giocattolo! Tenere lontano dalla portata dei neonati e dei bambini piccoli! Non metterli in testa, pericolo di soffocamento!

**WARNING!** Bags and film coverings are not toys! Please keep away from babies and small children! Do not put them over your head, risk of suffocation!



**VORSICHT, Verletzungsgefahr:**  
Kleinkinder dürfen sich nicht im Montage-Bereich aufhalten und an Möbeln hochziehen oder hinauf-

**PRÉCAUTION, risque de blessures:** Les jeunes enfants ne peuvent pas se tenir dans la zone de montage ni tirer ou grimper sur des

**PRECAUZIONE, pericolo di lesioni:** tenere i bambini lontano dal luogo di montaggio e evitare che si appendano o arrampichino sul mo-

**PRECAUTION, risk of injury:** Small children must keep away from the assembly area. They must refrain from climbing up on the furniture.

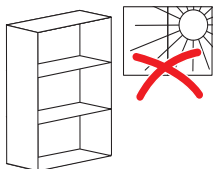
**1.****Allgemeine Hinweise****Remarques générales****Avvertenze generali****General information**

**ACHTUNG**  
**Direkte Sonneneinstrahlung:**  
Führt zu Farbveränderungen.

**ATTENTION**  
**Exposition directe au soleil:**  
Provoque des décolorations.

**ATTENZIONE**  
**Irraggiamento diretto del sole:**  
ne modifica il colore.

**ATTENTION**  
**Direct sunlight:**  
results in discolouration.

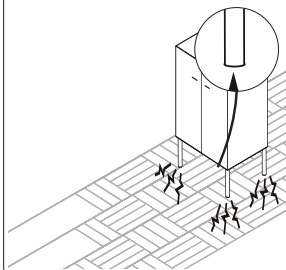

**Schutzgleiter:**  
Mit Schutzgleitern (z.B. aus Filz), lassen sich Schäden auf kratzem-pföndlichen Böden (z.B. Parkett) vermeiden.

**Patins:**  
Les patins (p.ex. en feutre) permettent d'éviter d'endommager les sols sensibles aux rayures (p.ex. parquet).

**Scivolante protettivo:**  
grazie agli scivolanti protettivi (ad es. feltro) si evita di danneggiare pavimenti sensibili ai graffi (ad es. parquet).

**Protective covers:**  
Protective covers, e.g. felt pads, prevent damage to floors that are easily scratched (e.g. parquet).

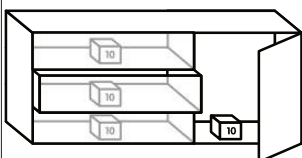

**Belastbarkeit:**  
Pro Korpus: je 10 kg  
Pro Schublade: je 10 kg  
Pro Hängeregal: total 10 kg  
Pro Hängetablar: total 5 kg

**Résilience:**  
Par corpus : 10 kg chacun  
Par tiroir : 10 kg chacun  
Par étagère suspendue : 10 kg au total  
Par étagère suspendue : 5 kg au total

**Resilienza:**  
Per carcassa: 10 kg ciascuno  
Per cassetto: 10 kg ciascuno  
Per ripiano sospeso: totale 10 kg  
Per ripiano sospeso: totale 5 kg

**Resilience:**  
Per carcasse: 10 kg each  
Per drawer: 10 kg each  
Per hanging shelf: total 10 kg  
Per hanging shelf: total 5 kg

**2. Montagehinweise      Instructions de montage      Istruzioni di montaggio      Assembly information**

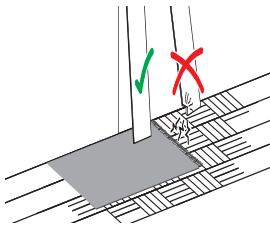

**Montageschäden:**

Vermeiden Sie, indem Sie einen sauberen und weichen Untergrund verwenden (z.B. Teppich). Teile beim Auspacken oder während der Montage nur auf weiche Unterlagen legen/stellen. Darauf achten, dass grössere Teile nicht kippen

**Dommages au montage:**

Évitez les dommages en utilisant un fond propre et doux (p.ex. tapis). Lors du déballage et montage, posez/placez les éléments uniquement sur un fond doux. Assurez-vous que les grands éléments ne peuvent pas basculer.

**Danni in fase di montaggio:**

evitare di causare danni utilizzando una base pulita e morbida (ad es. tappeto). Nella fase di disimballaggio e durante il montaggio, appoggiare i pezzi esclusivamente su una base morbida. Fare attenzione che i pezzi più grandi non si ribaltino.

**Damages during assembly:**

These can be avoided if you use a clean soft surface (e.g. carpet). Only place parts on a soft surface when unpacking or during the assembly. Make sure that larger parts can not tip over.



**Personen:**

Für die Montage erforderliche Anzahl Personen.

**Personnes:**

Nombre de personnes nécessaires au montage.

**Persone:**

numero di persone necessarie per il montaggio.

**People:**

Number of people required for the assembly.



**60'**

**Montagerichtzeit:**

Ungefähre Zeit in Stunden.

**Durée indicative du montage:**

Durée approximative en heures.

**Tempo di montaggio:**

tempo in ore appross.

**Assembly time:**

Approximate time in hours.

**Benötigtes Werkzeug:**

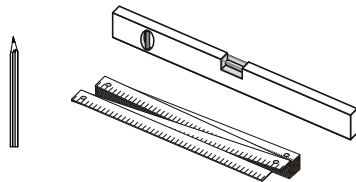

**Outils nécessaires:**

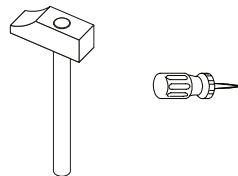

**Attrezzi necessari:**



**Tools required:**

**Bau-/Kleinteile:**

**Éléments/pièces:**

**Componenti/piccoli pezzi:**

**Components/small parts**

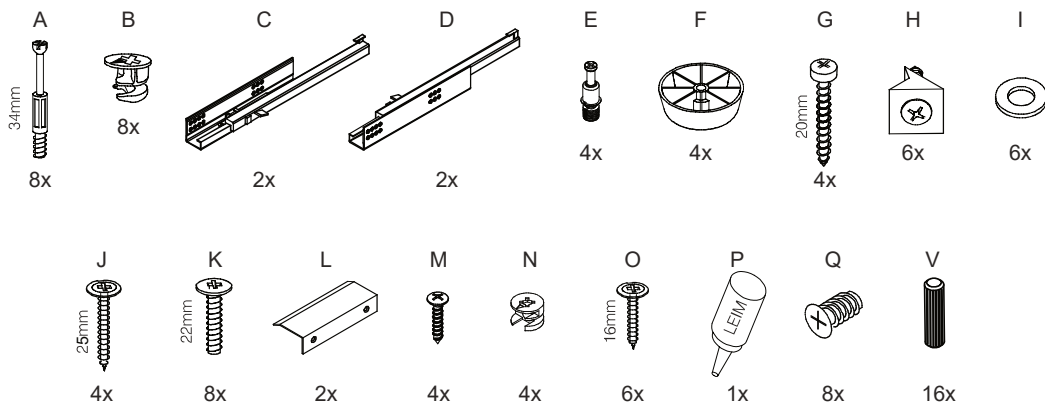

A

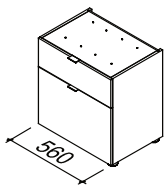

B

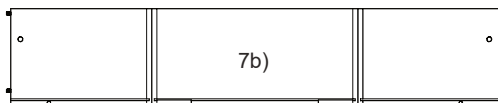
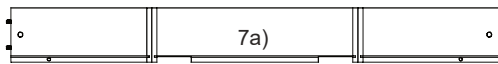
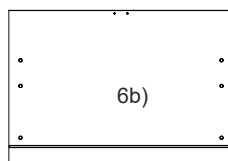
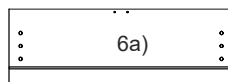
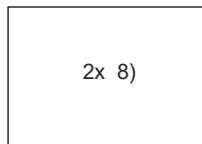
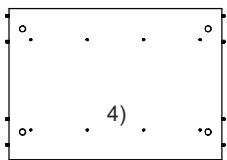
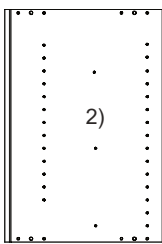
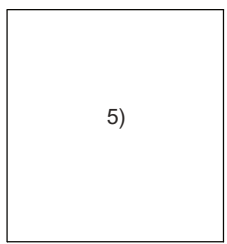
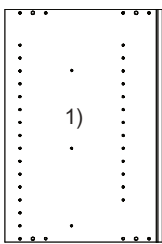
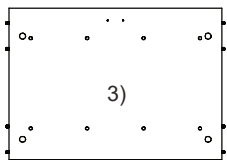
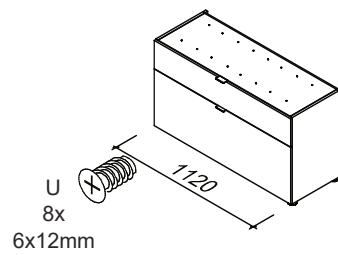
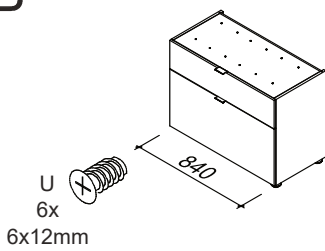

B

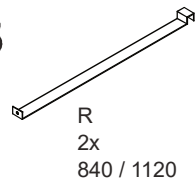

4x

T

1x

B

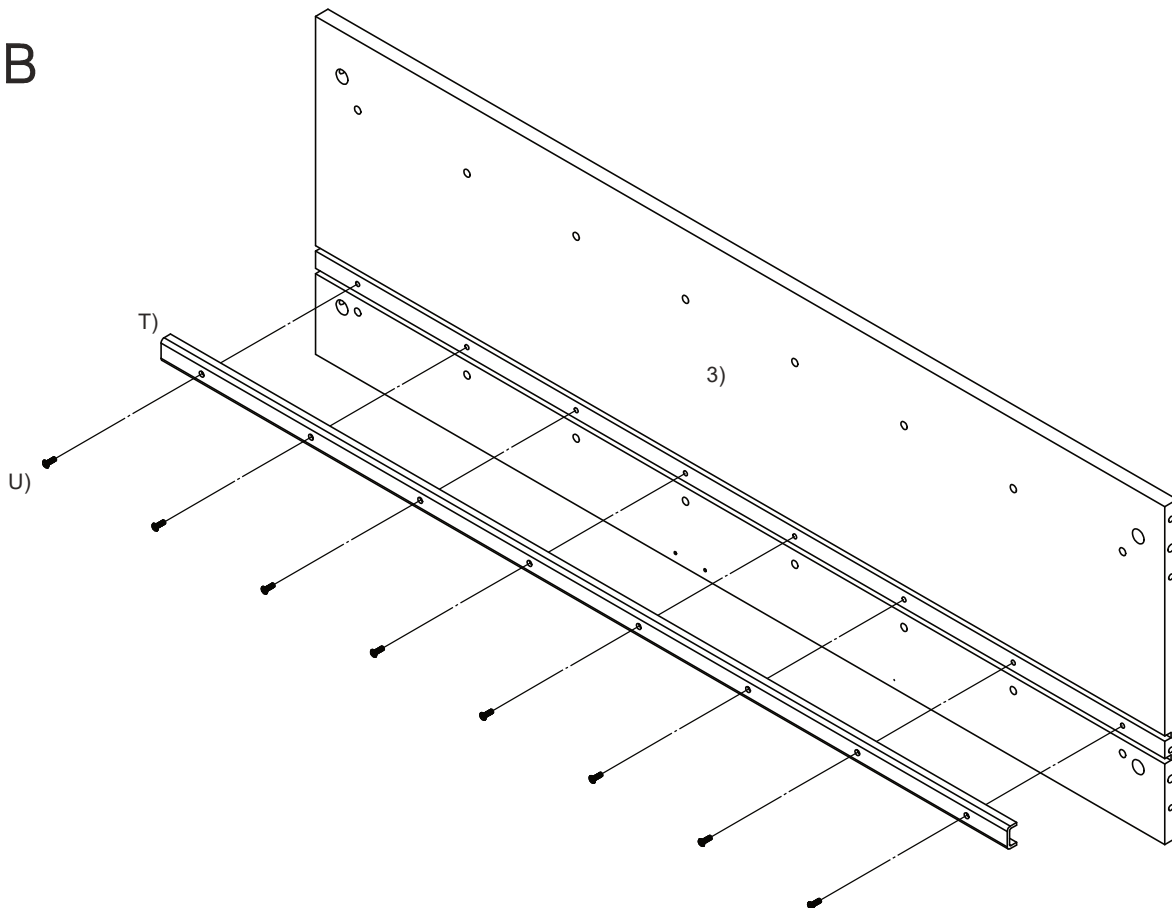

3.

**Montage-  
anleitung**

**Instructions  
de montage**

**Istruzioni per  
il montaggio**

**Assembling  
instruction**

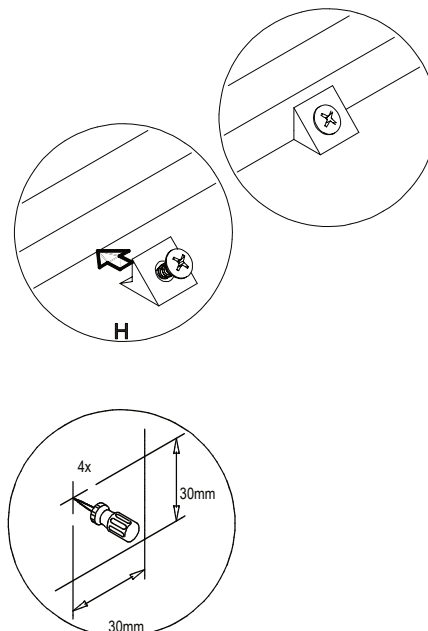
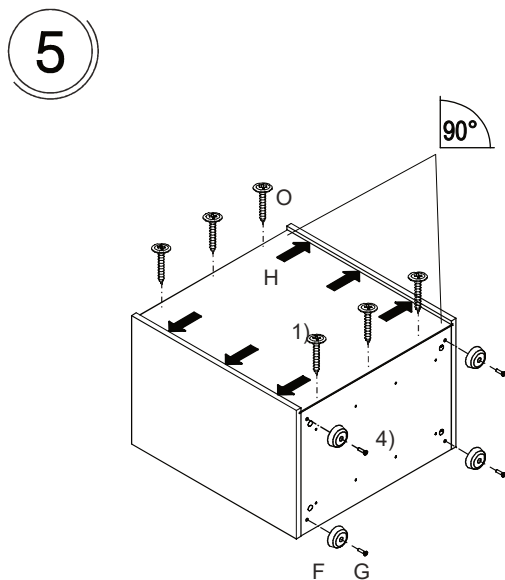
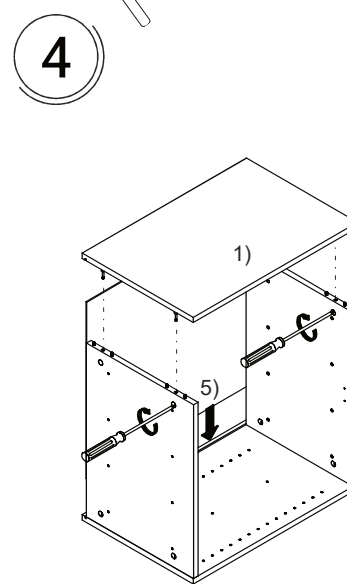
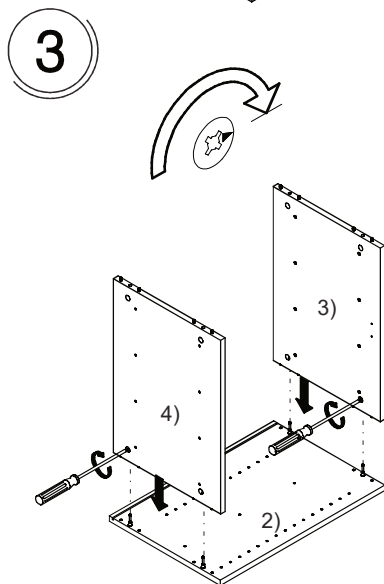
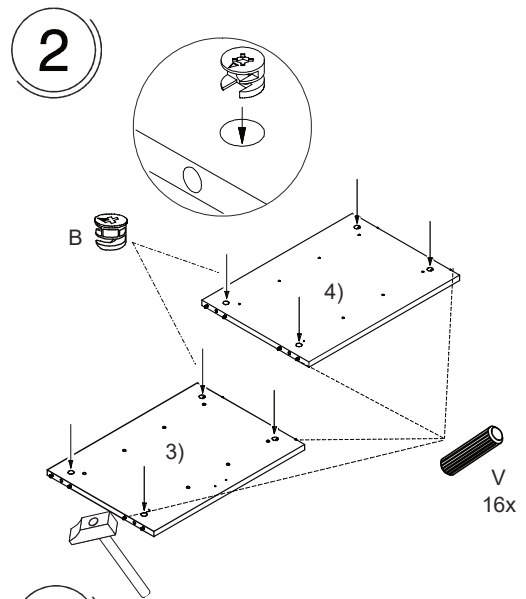
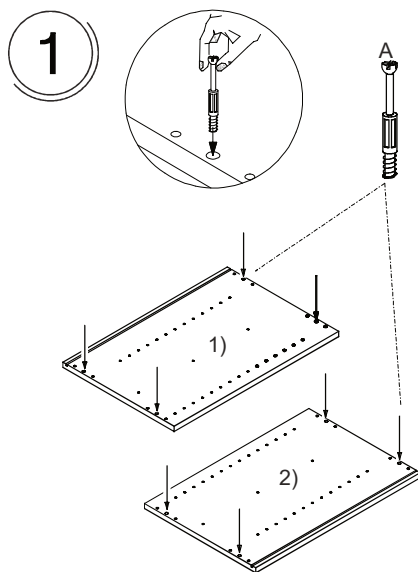

6

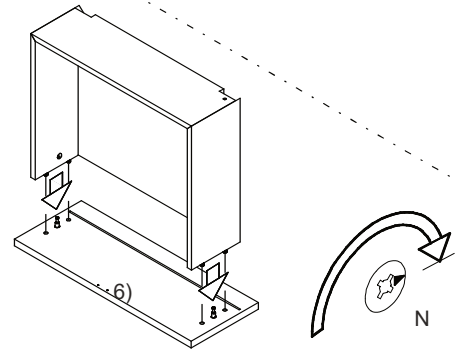
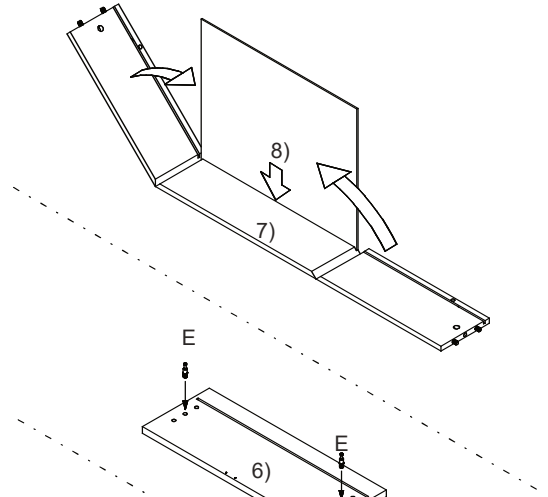
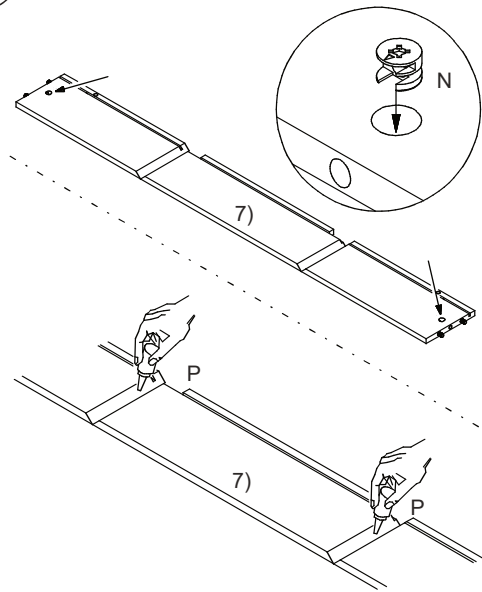

7

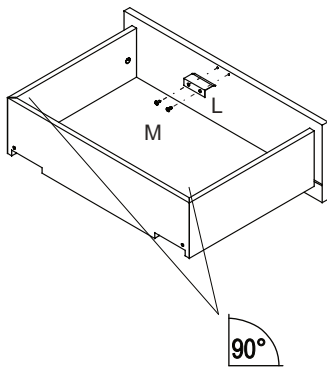

8

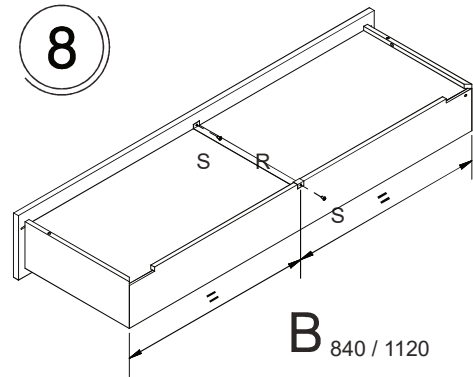

9

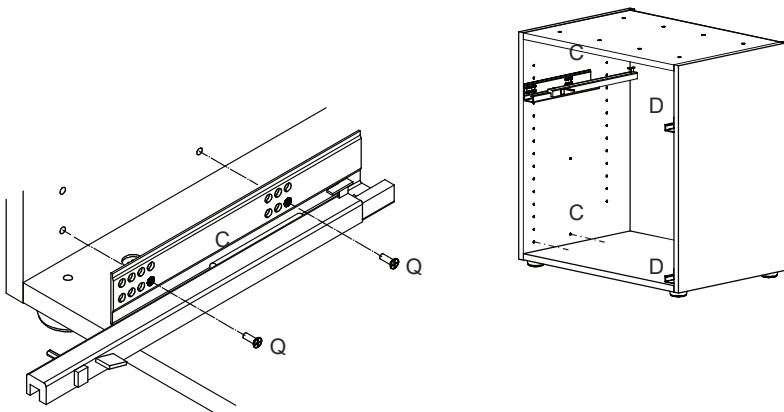

10

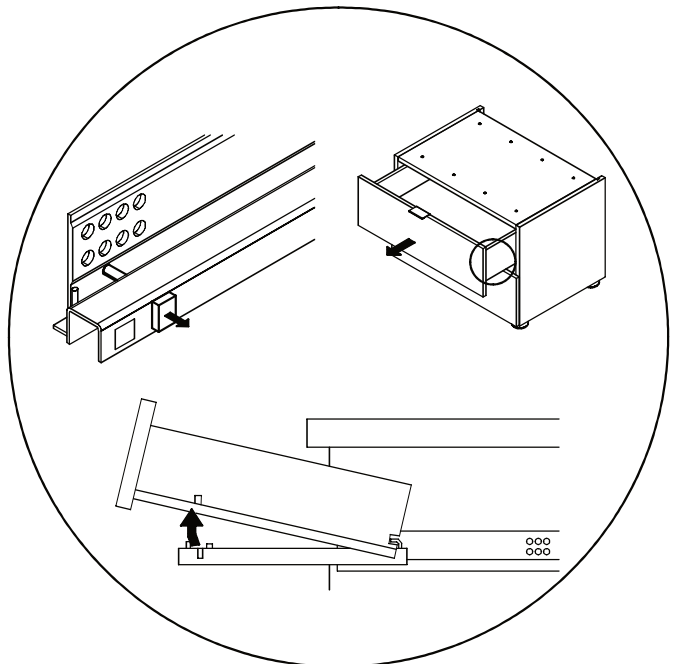
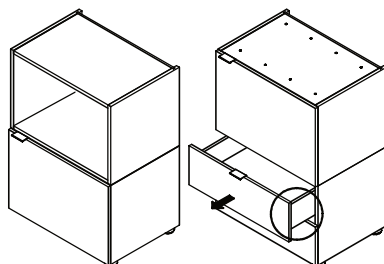
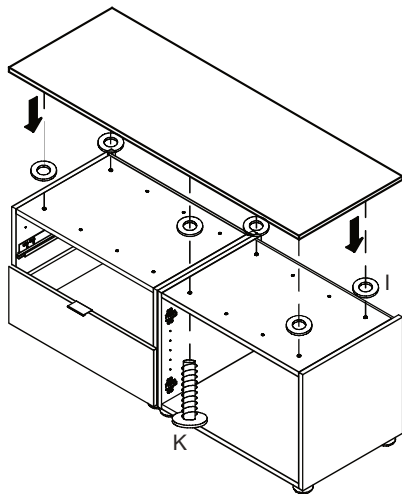
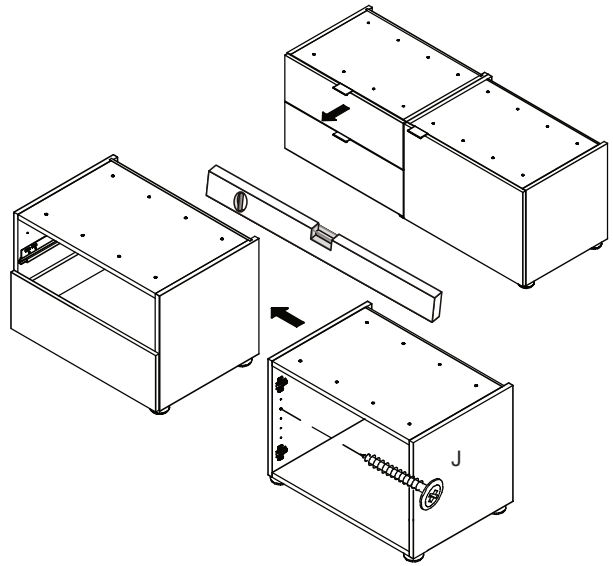
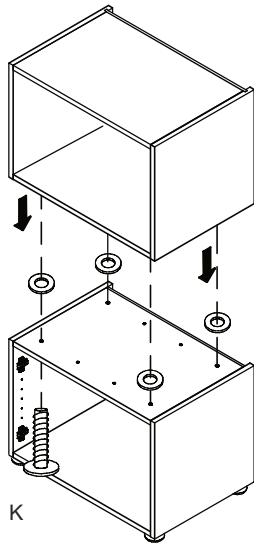
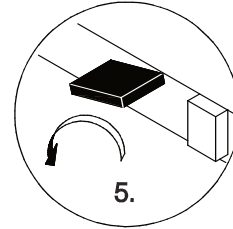
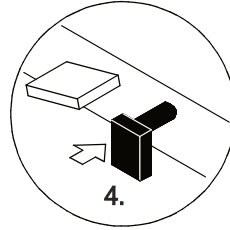
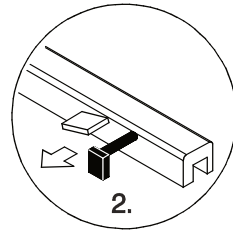
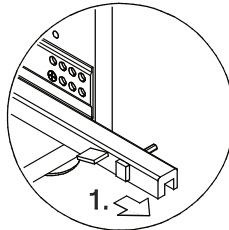
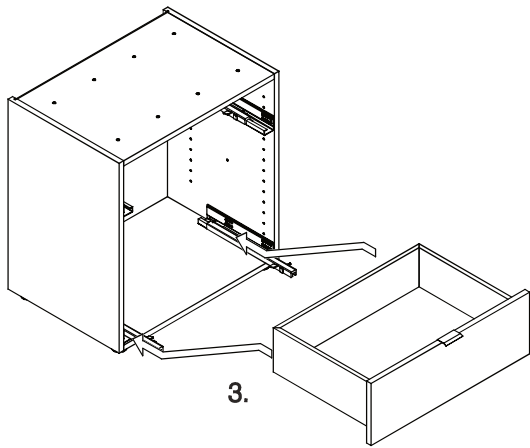

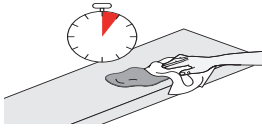

**Reinigung allgemein:**

Flecken immer sofort entfernen. Ein sauberes, weisses Tuch verwenden.



Sauberes Wasser verwenden. Lässt sich der Fleck so nicht entfernen, seifenhaltiges Wasser verwenden. Werden Reinigungsmittel verwendet, diese immer zuerst an einer nicht sichtbaren Stelle testen.



**ACHTUNG** Keine chemischen, scheuernden oder kratzenden

**Nettoyage en général:**

Toujours éliminer immédiatement les taches. Utiliser un chiffon blanc, propre.

Utiliser une eau propre. Si la tache ne s'enlève pas, utiliser une eau savonneuse. Si un produit de nettoyage est utilisé, toujours l'essayer préalablement dans un endroit invisible.

**ATTENTION** Ne pas utiliser de produits ou moyens chimiques, agressifs ou abrasifs.

**Pulizia generale:**

rimuovere sempre subito le macchie. Utilizzare un panno bianco, pulito.

Utilizzare acqua pulita. Se la macchia non viene via, utilizzare dell'acqua con sapone. Se si utilizzano dei detersivi, provarli sempre prima in un punto non visibile.

**ATTENZIONE** Non utilizzare detersivi chimici o prodotti/materiali abrasivi.

**General cleaning instructions:**

Always remove stains immediately. Use a clean, white cloth.

Use clean water. If the stain does not come out, use soapy water. If you use cleaning detergents, always test them first in a concealed spot.

**CAUTION** Do not use any chemical or abrasive cleaning detergents or cloths/tools.

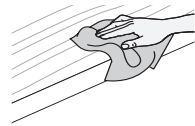
**Möbelpflege:**

Lackiertes Holz nur mit einem leicht feuchten Tuch abwischen.



Geölte Holzoberflächen je nach Gebrauch, von Zeit zu Zeit (z.B. vierteljährlich) erneut ölen.

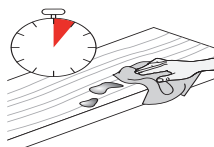

Feuchtigkeitsrückstände auf geölten und gewachsen Flächen müssen sofort entfernt werden. Ansonsten kommt es zu Fleckenbildung.



**ACHTUNG** Keine chemischen, scheuernden oder kratzenden Reinigungs-/Hilfsmittel verwenden.

**Entretien des meubles:**

Essuyer le bois vernis uniquement avec un chiffon légèrement humide.

Pour les surfaces en bois huilé, appliquer de temps à autre (p.ex. tous les 3 mois) et en fonction de l'utilisation une huile pour bois.

Les restes d'humidité sur les surfaces huilées et cirées doivent être immédiatement enlevés. Risque de formation de taches.

**ATTENTION** Ne pas utiliser de produits ou moyens chimiques, agressifs ou abrasifs.

**Cura dei mobili:**

pulire il legno laccato utilizzando soltanto un panno leggermente umido.

Le superfici di legno oliate di tanto in tanto, a seconda del loro utilizzo (ad es. ogni tre mesi), devono essere nuovamente trattate con olio.

È necessario eliminare subito i residui di umidità dalle superfici oliate e cerate, altrimenti c'è il rischio che si formino delle macchie.

**ATTENZIONE** Non utilizzare detersivi chimici o prodotti/materiali abrasivi.

**Furniture care:**

Only wipe varnished wood with a slightly damp cloth.

Re-oil oiled wooden surfaces from time to time (e.g. every three months) depending on use.

To prevent stains, immediately wipe off any wet spots on oiled and waxed surfaces.

**CAUTION** Do not use any chemical or abrasive cleaning detergents or cloths/tools.

5.	Wartung	Entretien	Manutenzio- ne	Maintenance
----	---------	-----------	-------------------	-------------



**Schrauben:**  
Für einwandfreie, zuverlässige Funktion, Schrauben regelmäßig nachziehen (z.B. vierteljährlich).

**Vis:**  
Resserrer régulièrement les vis (p.ex. tous les 3 mois) pour assurer un fonctionnement sûr et cor-

**Viti:**  
per garantire un funzionamento corretto e sicuro stringere regolarmente le viti (ad es. ogni tre mesi).

**Screws:**  
To keep your furniture in good working order, tighten the screws regularly (e.g. every three

6.	Entsorgung	Élimination	Smaltimento	Disposal
----	------------	-------------	-------------	----------



Entsorgungsservice:  
Micasa bietet Ihnen einen Entsorgungsservice an. Weitere Informationen erhalten Sie unter [www.micasa.ch](http://www.micasa.ch)

Entsorgung:  
Nicht mehr verwendete Möbel der fachgerechten Entsorgung übergeben. Wenden Sie sich an Ihre lokale Entsorgungsstelle.

Service d'élimination:  
Micasa vous propose un service d'élimination. Vous trouverez des informations supplémentaires sur [www.micasa.ch](http://www.micasa.ch)

Élimination:  
Veuillez remettre les meubles qui ne sont plus utilisés à une entreprise d'élimination. Adressez-vous à votre centre de collecte local.

Servizio di smaltimento:  
Micasa vi offre un servizio di smaltimento. Ulteriori informazioni sono disponibili su [www.micasa.ch](http://www.micasa.ch)

Smaltimento:  
i mobili dismessi devono essere conferiti presso i centri di raccolta rifiuti per il loro corretto smaltimento. Rivolgersi presso il

Disposal service:  
Micasa offers a disposal service. For more information visit [www.micasa.ch](http://www.micasa.ch)

Disposal:  
To correctly dispose of furniture that is no longer used, contact your local recycling centre.

7.	Kontakt / Service	Contact / service	Contatto / servizio	Contact / service
----	----------------------	----------------------	------------------------	----------------------



Fragen / Anregungen:  
Wir sind gerne für Sie erreichbar:  
Montag bis Freitag  
08.00 bis 18.00 Uhr  
Samstag  
08.30 bis 16.30 Uhr  
Tel. 0800 840 848

Questions / suggestions:  
Nous sommes à votre disposition:  
Lundi - vendredi  
08h00 à 18h00  
Samedi  
08h30 à 16h30  
Tél. 0800 840 848

Domande / suggerimenti:  
siamo a vostra disposizione:  
lunedì - venerdì  
dalle 08.00 alle 18.00  
sabato  
dalle 08.30 alle 16.30  
Tel. 0800 840 848

Questions / Suggestions  
Please contact us. Our opening times are:  
Monday - Friday  
8.00 to 18.00  
Saturday  
8.30 to 16.30  
Phone 0800 840 848



Ersatzteile:  
Erhalten Sie direkt im Online-Shop von Migros-Service:  
[www.migros-service.ch](http://www.migros-service.ch)

Pièces de rechange:  
Vous les obtenez directement dans le magasin en ligne de Migros-Service:  
[www.migros-service.ch](http://www.migros-service.ch)

Pezzi di ricambio:  
sono disponibili direttamente sull'online-shop di Migros-Service:  
[www.migros-service.ch](http://www.migros-service.ch)

Spare parts:  
Available directly from the Migros-Service online shop:  
[www.migros-service.ch](http://www.migros-service.ch)

**Wichtig:**  
Vor Gebrauch sorgfältig durchlesen/  
Montageanleitung für  
späteres Nachlesen  
aufbewahren

**Important:**  
Lisez attentivement/  
conserver les instruc-  
tions d'installation  
pour référence future  
avant utilisation

**Importante:**  
lettura/conservare  
Istruzioni per l'instal-  
lazione per riferimen-  
to futuro accurata-  
mente prima dell'uso

**Important:**  
Read carefully before  
assembling/keep and  
store Instruction for  
reference

# TILL

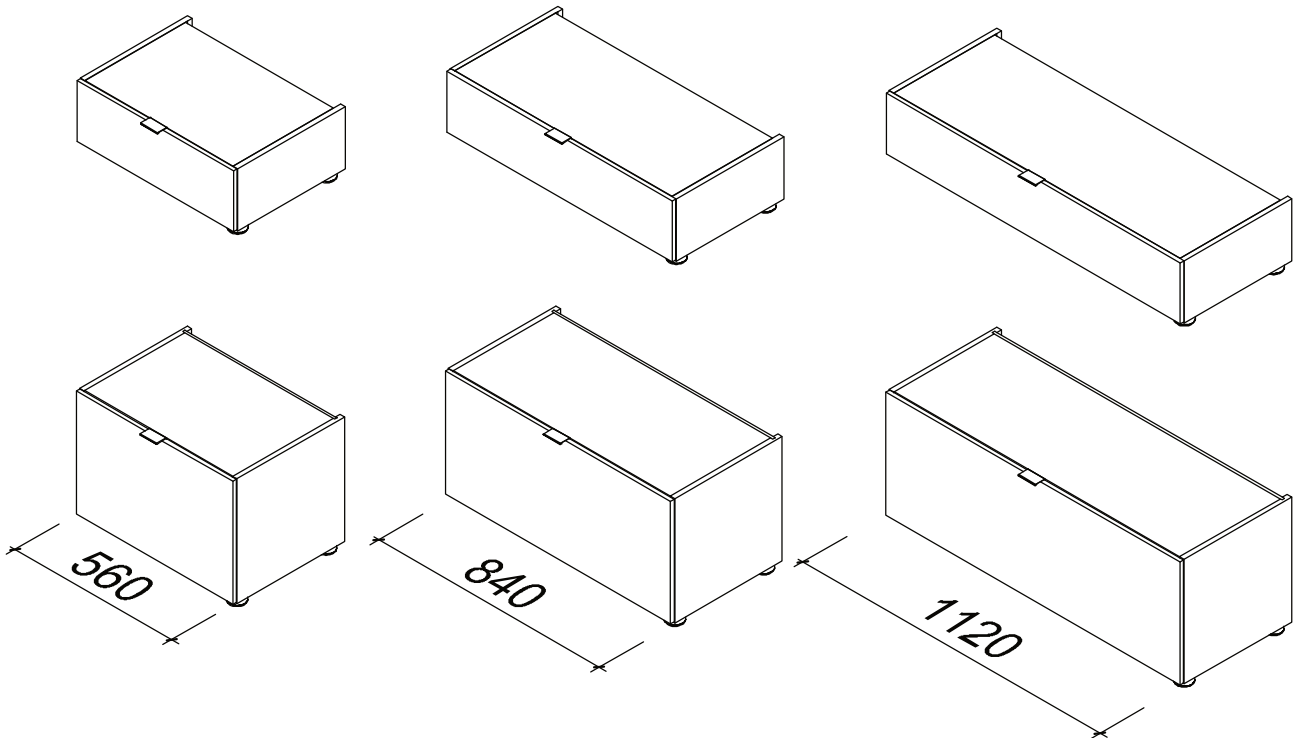



## Warnhinweise

### Bestimmungsgemässer Gebrauch:

Bitte achten Sie darauf, dass Ihre Möbel nur Ihrem Zweck gemäss verwendet werden. Für eine dauerhafte Funktionsfähigkeit ist eine sachgerechte Nutzung und regelmässige Unterhaltungspflege sehr wichtig.

## Mises en garde

### Utilisation conforme:

Veillez vous assurer que vos meubles sont utilisés uniquement pour leur usage prévu. Un entretien régulier et une utilisation conforme sont essentiels pour assurer un fonctionnement durable.

## Avvertenze

### Utilizzo per lo scopo previsto:

assicuratevi che i vostri mobili siano utilizzati solo per lo scopo per cui sono stati realizzati. Per garantire il loro funzionamento nel tempo è importante utilizzarli correttamente e sottoporli regolarmente a cure manutentive.

## Warning notice

### Intended use:

Please make sure that you only use your furniture for the purpose it was designed for. Correct use and regular maintenance are essential for ensuring your furniture remains in working order for the long-term.

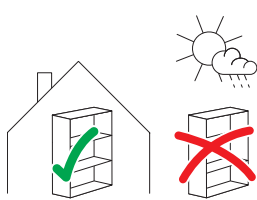

### Anwendung:

Das von Ihnen erworbene Behältnismöbel eignet sich für den allgemeinen, privaten Wohnbereich. Es ist nicht für den Nass-, Aussen- oder gewerblichen Bereich geeignet.

### Usage:

Le meuble de rangement que vous avez acheté convient pour l'habitat privé en général. Il ne convient pas pour l'extérieur, les milieux humides ou le domaine commercial.

### Impiego:

il mobile contenitore acquistato è adatto per un utilizzo in generale, in ambiente domestico. Non è adatto per gli esterni, per l'esposizione alla pioggia o per ambienti commerciali.

### Area of use:

The storage furniture you have purchased is suitable for use in general private living quarters. It is not suitable for areas that are wet, outside or used for commercial purposes.

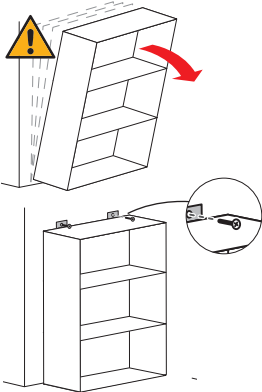

### VORSICHT, dieses Möbel kann Kippen.

Um dies zu verhindern, muss es mit Kippsicherung(en) an der Wand / Decke befestigt werden. Die Befestigung ist abhängig von der Wand-/Deckenbeschaffenheit (z.B. Beton/Gips/Backstein/Holz) und muss von einem Fachmann ausgeführt werden.

### PRÉCAUTION, ce meuble peut basculer.

Pour empêcher cela, il doit être fixé au mur/plafond avec une sécurité anti-basculement. La fixation dépend de la nature du mur/plafond (p.ex. béton/plâtre/brique/bois) et doit être réalisée par un spécialiste.

### PRECAUZIONE, questo mobile può ribaltarsi.

Per evitare questo, deve essere adeguatamente fissato alla parete o al soffitto. Il tipo di fissaggio dipende dalle caratteristiche della parete o del soffitto (ad es. cemento/gesso/mattone/legno) e il fissaggio deve essere eseguito da un esperto.

### PRECAUTION, this piece of furniture can tip over.

To prevent this it must be secured to the wall or ceiling with brackets. The type of bracket depends on the quality of the wall and/or ceiling (e.g. concrete, plaster, brick, wood) and must be mounted by a specialist.

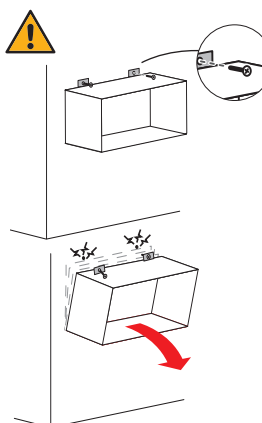

### VORSICHT, dieses Möbel kann runterfallen:

Um dies zu verhindern, muss es richtig an der Wand / Decke befestigt werden. Die Befestigung ist abhängig von der Wand-/Deckenbeschaffenheit (z.B. Beton/Gips/Backstein/Holz) und muss von einem Fachmann ausgeführt werden.

### PRÉCAUTION, ce meuble peut tomber:

Pour empêcher cela, il doit être fixé correctement au mur/plafond. La fixation dépend de la nature du mur/plafond (p.ex. béton/plâtre/brique/bois) et doit être réalisée par un spécialiste.

### PRECAUZIONE, questo mobile può cadere:

per evitare questo, deve essere adeguatamente fissato alla parete o al soffitto. Il tipo di fissaggio dipende dalle caratteristiche della parete o del soffitto (ad es. cemento/gesso/mattone/legno) e il fissaggio deve essere eseguito da un esperto.

### PRECAUTION, this piece of furniture can fall down:

To prevent this, it must be secured properly to the wall or ceiling. The type of bracket depends on the quality of the wall and/or ceiling (e.g. concrete, plaster, brick, wood) and must be mounted by a specialist.

**Warnhinweise****Mises en garde****Avvertenze****Warning notice**

**WARNUNG**  
**Verschluck- und Erstickungsgefahr:**  
Kleinteile und Verpackungsmaterial können verschluckt werden.

**AVERTISSEMENT**  
**Risque d'ingestion et d'étouffement:**  
Les petites pièces et le matériel d'emballage peuvent être avalés.

**AVVERTENZA**  
**Pericolo di ingestione e soffocamento:**  
piccole parti e materiale di imballaggio possono essere ingerite.

**WARNING**  
**Risk of swallowing and choking:**  
Small parts and packaging material may be swallowed.



**WARNUNG!** Tüten und Folien sind kein Spielzeug! Bitte von Babys und Kleinkindern fernhalten! Nicht über den Kopf ziehen; Erstickungsgefahr!

**AVERTISSEMENT!**  
Les sacs et films ne sont pas des jouets! Veuillez les tenir hors de portée des bébés et jeunes enfants! Ne pas mettre sur la tête, risque d'étouffement!

**AVVERTENZA!** Sacchetti e pellicole non sono un giocattolo! Tenere lontano dalla portata dei neonati e dei bambini piccoli! Non metterli in testa, pericolo di soffocamento!

**WARNING!** Bags and film coverings are not toys! Please keep away from babies and small children! Do not put them over your head, risk of suffocation!



**VORSICHT,**  
**Verletzungsgefahr:**  
Kleinkinder dürfen sich nicht im Montage-Bereich aufhalten und an Möbeln hochziehen oder hinauf-

**PRÉCAUTION,**  
**risque de blessures:** Les jeunes enfants ne peuvent pas se tenir dans la zone de montage ni tirer ou grimper sur des

**PRECAUZIONE,**  
**pericolo di lesioni:** tenere i bambini lontano dal luogo di montaggio e evitare che si appendano o arrampichino sul mo-

**PRECAUTION,**  
**risk of injury:** Small children must keep away from the assembly area. They must refrain from climbing up on the furniture.

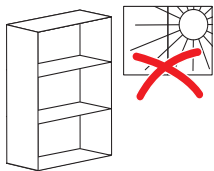
**1.****Allgemeine Hinweise****Remarques générales****Avvertenze generali****General information**

**ACHTUNG**  
**Direkte Sonneneinstrahlung:**  
Führt zu Farbveränderungen.

**ATTENTION**  
**Exposition directe au soleil:**  
Provoque des décolorations.

**ATTENZIONE**  
**Irraggiamento diretto del sole:**  
ne modifica il colore.

**ATTENTION**  
**Direct sunlight:** results in discolouration.

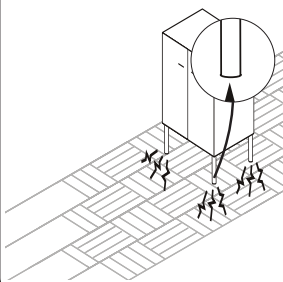

**Schutzgleiter:**  
Mit Schutzgleitern (z.B. aus Filz), lassen sich Schäden auf kratzempfindlichen Böden (z.B. Parkett) vermeiden.

**Patins:**  
Les patins (p.ex. en feutre) permettent d'éviter d'endommager les sols sensibles aux rayures (p.ex. parquet).

**Scivolante protettivo:**  
grazie agli scivolanti protettivi (ad es. feltro) si evita di danneggiare pavimenti sensibili ai graffi (ad es. parquet).

**Protective covers:**  
Protective covers, e.g. felt pads, prevent damage to floors that are easily scratched (e.g. parquet).

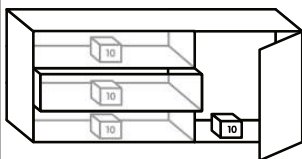

**Belastbarkeit:**  
Pro Korpus: je 10 kg  
Pro Schublade: je 10 kg  
Pro Hängeregal: total 10 kg  
Pro Hängetablar: total 5 kg

**Résilience:**  
Par corpus : 10 kg chacun  
Par tiroir : 10 kg chacun  
Par étagère suspendue : 10 kg au total  
Par étagère suspendue : 5 kg au total

**Resilienza:**  
Per carcassa: 10 kg ciascuno  
Per cassetto: 10 kg ciascuno  
Per ripiano sospeso: totale 10 kg  
Per ripiano sospeso: totale 5 kg

**Resilience:**  
Per carcasse: 10 kg each  
Per drawer: 10 kg each  
Per hanging shelf: total 10 kg  
Per hanging shelf: total 5 kg

**2. Montagehinweise      Instructions de montage      Istruzioni di montaggio      Assembly information**

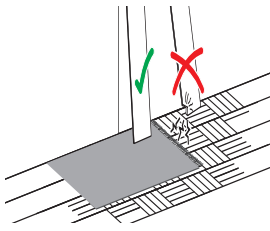

**Montageschäden:**

Vermeiden Sie, indem Sie einen sauberen und weichen Untergrund verwenden (z.B. Teppich). Teile beim Auspacken oder während der Montage nur auf weiche Unterlagen legen/stellen. Darauf achten, dass grössere Teile nicht kippen

**Dommages au montage:**

Évitez les dommages en utilisant un fond propre et doux (p.ex. tapis). Lors du déballage et montage, posez/placez les éléments uniquement sur un fond doux. Assurez-vous que les grands éléments ne peuvent pas basculer.

**Danni in fase di montaggio:**

evitare di causare danni utilizzando una base pulita e morbida (ad es. tappeto). Nella fase di disimballaggio e durante il montaggio, appoggiare i pezzi esclusivamente su una base morbida. Fare attenzione che i pezzi più grandi non si ribaltino.

**Damages during assembly:**

These can be avoided if you use a clean soft surface (e.g. carpet). Only place parts on a soft surface when unpacking or during the assembly. Make sure that larger parts can not tip over.



**Personen:**

Für die Montage erforderliche Anzahl Personen.

**Personnes:**

Nombre de personnes nécessaires au montage.

**Persone:**

numero di persone necessarie per il montaggio.

**People:**

Number of people required for the assembly.



**60'**

**Montagerichtzeit:**

Ungefähre Zeit in Stunden.

**Durée indicative du montage:**

Durée approximative en heures.

**Tempo di montaggio:**

tempo in ore appross.

**Assembly time:**

Approximate time in hours.

**Benötigtes Werkzeug:**

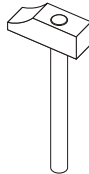
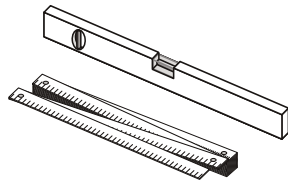

**Outils nécessaires:**

**Attrezzi necessari:**

**Tools required:**

**Bau-/Kleinteile:**

**Éléments/pièces:**

**Componenti/piccoli pezzi:**

**Components/small parts**

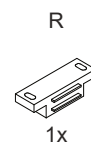
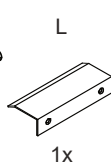
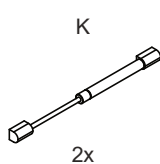
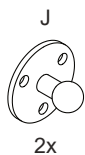
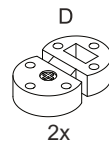

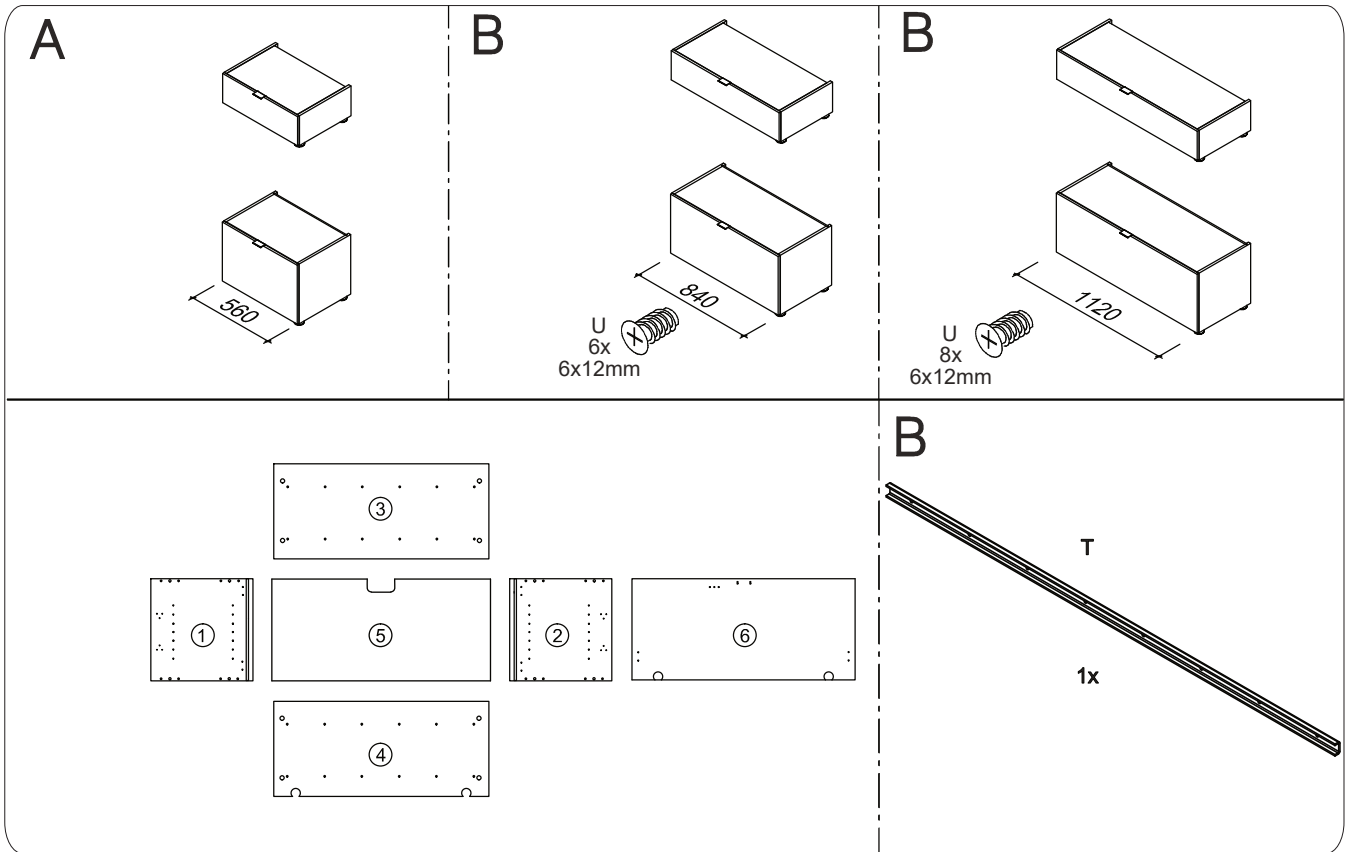

**3.**

**Montage-  
anleitung**

**Instructions  
de montage**

**Istruzioni per  
il montaggio**

**Assembling  
instruction**

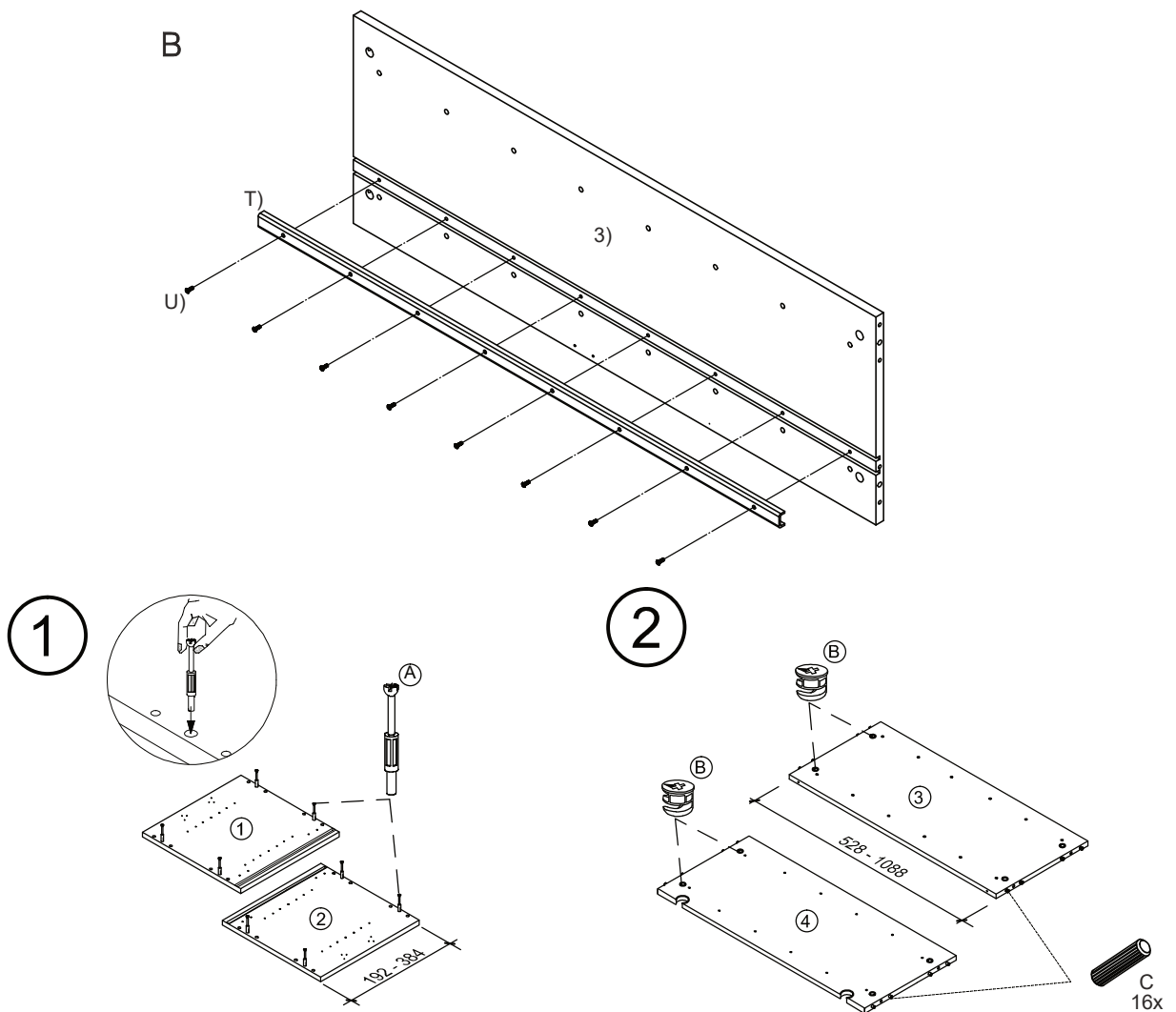

3

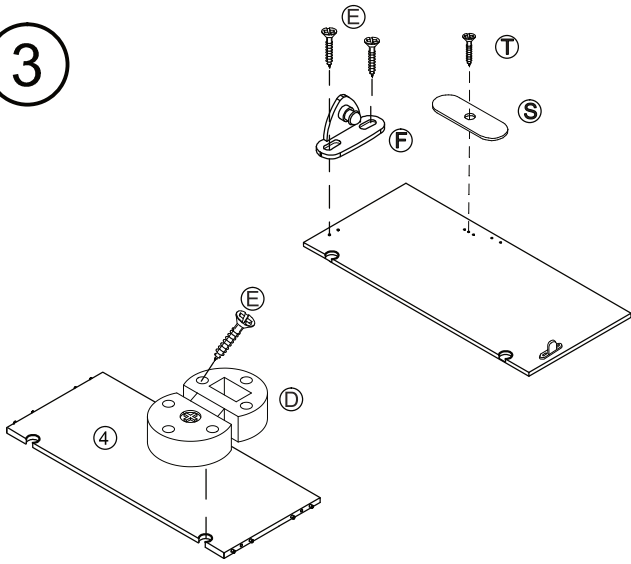

4

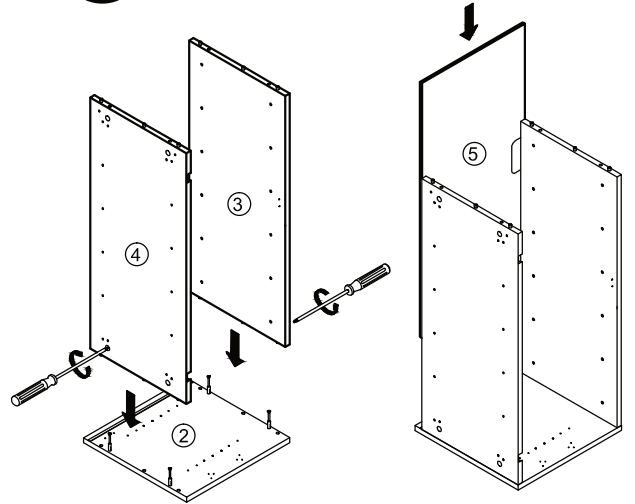

5

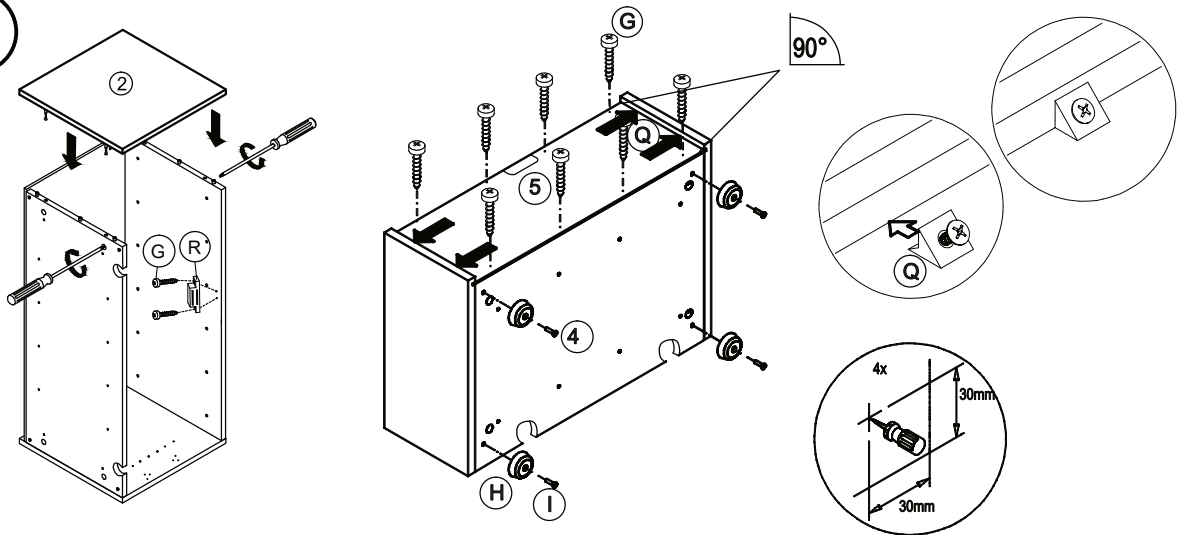

6

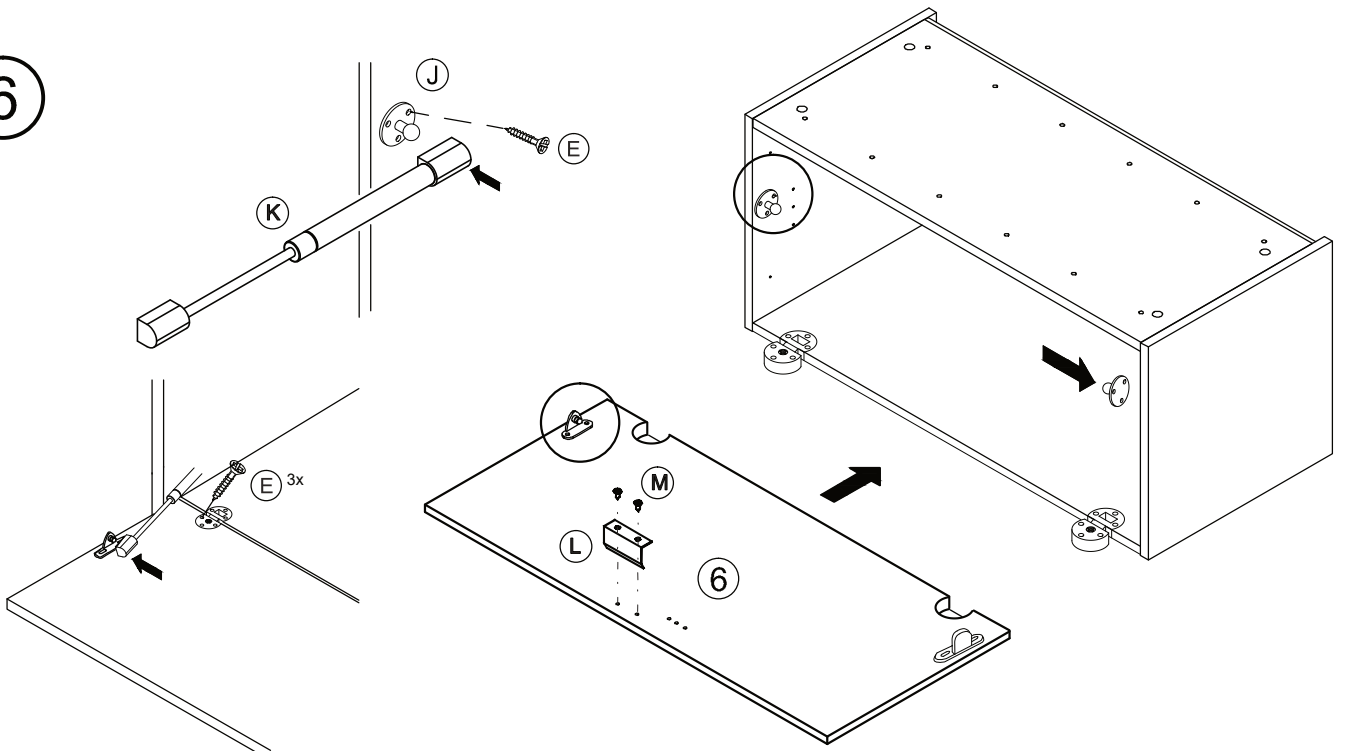



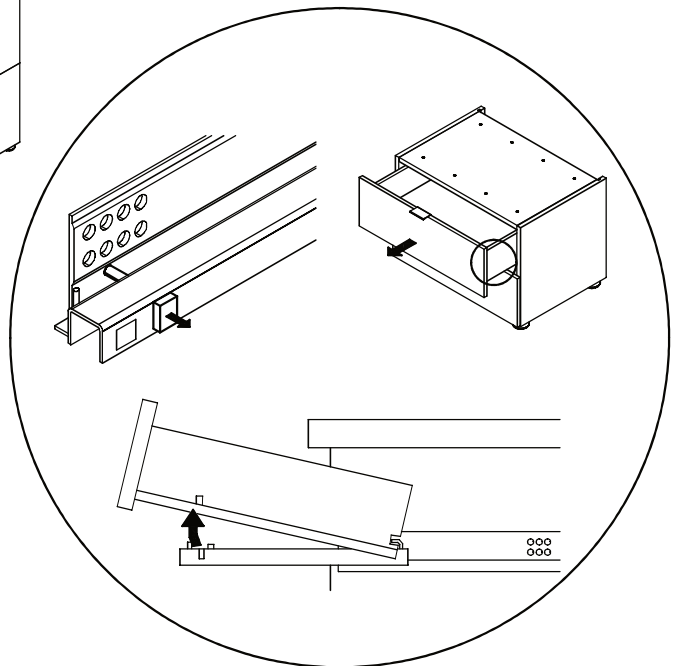
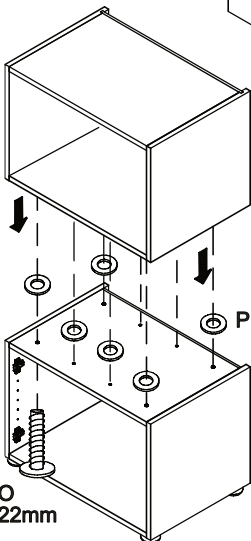
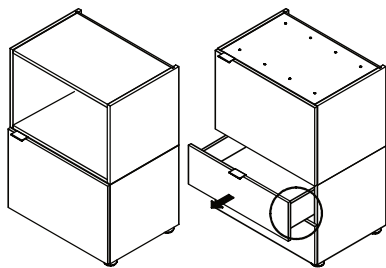
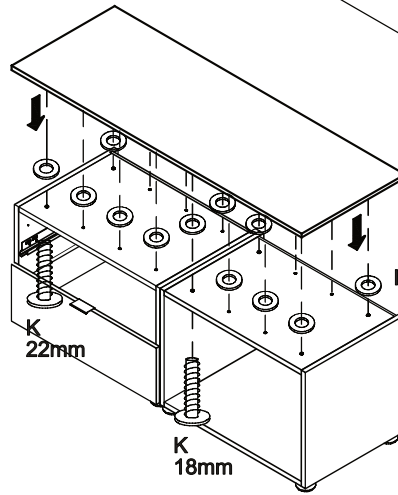
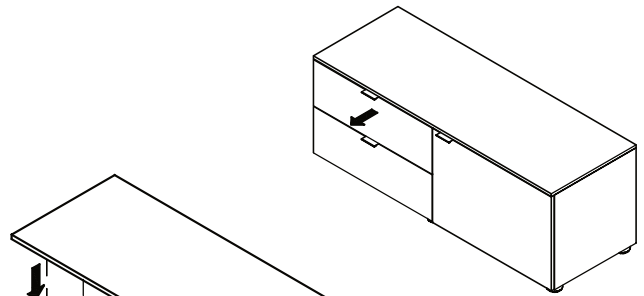
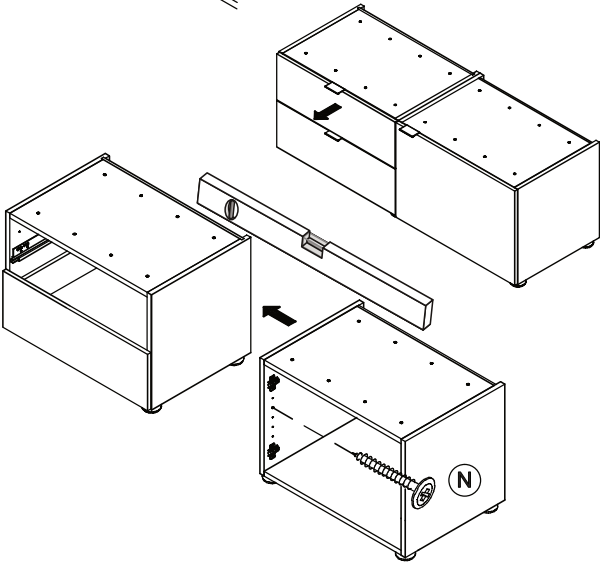
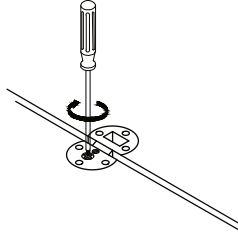
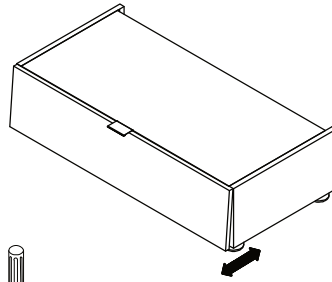
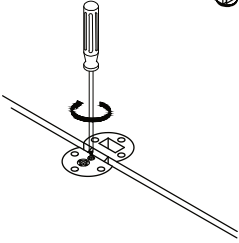
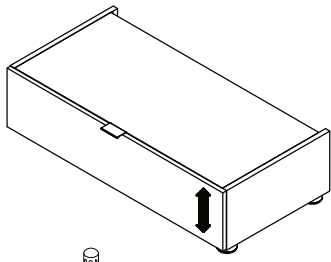

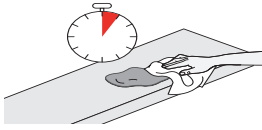
**Reinigung allgemein:**

Flecken immer sofort entfernen. Ein sauberes, weisses Tuch verwenden.



Sauberes Wasser verwenden. Lässt sich der Fleck so nicht entfernen, seifenhaltiges Wasser verwenden. Werden Reinigungsmittel verwendet, diese immer zuerst an einer nicht sichtbaren Stelle testen.



**ACHTUNG** Keine chemischen, scheuernden oder kratzenden

**Nettoyage en général:**

Toujours éliminer immédiatement les taches. Utiliser un chiffon blanc, propre.

Utiliser une eau propre. Si la tache ne s'enlève pas, utiliser une eau savonneuse. Si un produit de nettoyage est utilisé, toujours l'essayer préalablement dans un endroit invisible.

**ATTENTION** Ne pas utiliser de produits ou moyens chimiques, agressifs ou abrasifs.

**Pulizia generale:**

rimuovere sempre subito le macchie. Utilizzare un panno bianco, pulito.

Utilizzare acqua pulita. Se la macchia non viene via, utilizzare dell'acqua con sapone. Se si utilizzano dei detersivi, provarli sempre prima in un punto non visibile.

**ATTENZIONE** Non utilizzare detersivi chimici o prodotti/materiali abrasivi.

**General cleaning instructions:**

Always remove stains immediately. Use a clean, white cloth.

Use clean water. If the stain does not come out, use soapy water. If you use cleaning detergents, always test them first in a concealed spot.

**CAUTION** Do not use any chemical or abrasive cleaning detergents or cloths/tools.

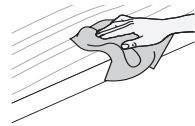
**Möbelpflege:**

Lackiertes Holz nur mit einem leicht feuchten Tuch abwischen.

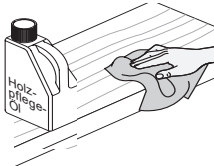

Geölte Holzoberflächen je nach Gebrauch, von Zeit zu Zeit (z.B. vierteljährlich) erneut ölen.

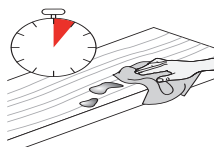

Feuchtigkeitsrückstände auf geölten und gewachsen Flächen müssen sofort entfernt werden. Ansonsten kommt es zu Fleckenbildung.



**ACHTUNG** Keine chemischen, scheuernden oder kratzenden Reinigungs-/Hilfsmittel verwenden.

**Entretien des meubles:**

Essuyer le bois vernis uniquement avec un chiffon légèrement humide.

Pour les surfaces en bois huilé, appliquer de temps à autre (p.ex. tous les 3 mois) et en fonction de l'utilisation une huile pour bois.

Les restes d'humidité sur les surfaces huilées et cirées doivent être immédiatement enlevés. Risque de formation de taches.

**ATTENTION** Ne pas utiliser de produits ou moyens chimiques, agressifs ou abrasifs.

**Cura dei mobili:**

pulire il legno laccato utilizzando soltanto un panno leggermente umido.

Le superfici di legno oliate di tanto in tanto, a seconda del loro utilizzo (ad es. ogni tre mesi), devono essere nuovamente trattate con olio.

È necessario eliminare subito i residui di umidità dalle superfici oliate e cerate, altrimenti c'è il rischio che si formino delle macchie.

**ATTENZIONE** Non utilizzare detersivi chimici o prodotti/materiali abrasivi.

**Furniture care:**

Only wipe varnished wood with a slightly damp cloth.

Re-oil oiled wooden surfaces from time to time (e.g. every three months) depending on use.

To prevent stains, immediately wipe off any wet spots on oiled and waxed surfaces.

**CAUTION** Do not use any chemical or abrasive cleaning detergents or cloths/tools.

**Schrauben:**

Für einwandfreie, zuverlässige Funktion, Schrauben regelmäßig nachziehen (z.B. vierteljährlich).

**Vis:**

Resserrer régulièrement les vis (p.ex. tous les 3 mois) pour assurer un fonctionnement sûr et cor-

**Viti:**

per garantire un funzionamento corretto e sicuro stringere regolarmente le viti (ad es. ogni tre mesi).

**Screws:**

To keep your furniture in good working order, tighten the screws regularly (e.g. every three

**Scharniere:**

Für einwandfreie, zuverlässige Funktion Topfbänder und Scharniere regelmäßig kontrollieren und falls nötig justieren (z.B. vierteljährlich).

**Charnières:**

Pour un fonctionnement sûr et correct, les paumelles et charnières doivent être régulièrement contrôlées et le cas échéant réajustées (p.ex. tous les 3

**Cerniere:**

per un funzionamento corretto e sicuro controllare regolarmente le cerniere a tazza e le cerniere in generale e se necessario regolarle (ad es. ogni tre mesi).

**Hinges:**

To ensure all the hinges and concealed hinges continue to work smoothly, check them regularly and adjust them if necessary (e.g.

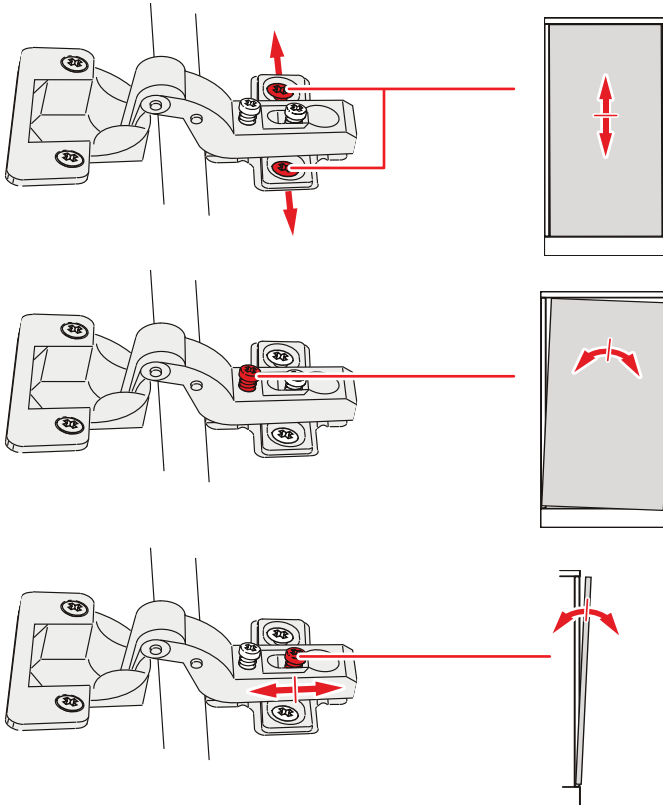

**6.****Entsorgung****Élimination****Smaltimento****Disposal**

Entsorgungsservice:

Micasa bietet Ihnen einen Entsorgungsservice an. Weitere Informationen erhalten Sie unter [www.micasa.ch](http://www.micasa.ch)

Entsorgung:  
Nicht mehr verwendete Möbel der fachgerechten Entsorgung übergeben. Wenden Sie sich an Ihre lokale Entsorgungsstelle.

Service d'élimination:

Micasa vous propose un service d'élimination. Vous trouverez des informations supplémentaires sur [www.micasa.ch](http://www.micasa.ch)

Élimination:  
Veuillez remettre les meubles qui ne sont plus utilisés à une entreprise d'élimination. Adressez-vous à votre centre de collecte local.

Servizio di smaltimento:

Micasa vi offre un servizio di smaltimento. Ulteriori informazioni sono disponibili su

[www.micasa.ch](http://www.micasa.ch)

Smaltimento:  
i mobili dismessi devono essere conferiti presso i centri di raccolta rifiuti per il loro corretto smaltimento. Rivolgersi presso il

Disposal service:

Micasa offers a disposal service. For more information visit

[www.micasa.ch](http://www.micasa.ch)

Disposal:  
To correctly dispose of furniture that is no longer used, contact your local recycling centre.

**7.****Kontakt / Service****Contact / service****Contatto / servizio****Contact / service**

Fragen / Anregungen:  
Wir sind gerne für Sie erreichbar:  
Montag bis Freitag  
08.00 bis 18.00 Uhr  
Samstag  
08.30 bis 16.30 Uhr  
Tel. 0800 840 848

Questions / suggestions:  
Nous sommes à votre disposition:  
Lundi - vendredi  
08h00 à 18h00  
Samedi  
08h30 à 16h30  
Tél. 0800 840 848

Domande / suggerimenti:  
siamo a vostra disposizione:  
lunedì - venerdì  
dalle 08.00 alle 18.00  
sabato  
dalle 08.30 alle 16.30  
Tel. 0800 840 848

Questions / Suggestions  
Please contact us.  
Our opening times are:  
Monday - Friday  
8.00 to 18.00  
Saturday  
8.30 to 16.30  
Phone 0800 840 848



Ersatzteile:  
Erhalten Sie direkt im Online-Shop von Migros-Service:

[www.migros-service.ch](http://www.migros-service.ch)

Pièces de rechange:  
Vous les obtenez directement dans le magasin en ligne de Migros-Service:

[www.migros-service.ch](http://www.migros-service.ch)

Pezzi di ricambio:  
sono disponibili direttamente sull'online-shop di Migros-Service:

[www.migros-service.ch](http://www.migros-service.ch)

Spare parts:  
Available directly from the Migros-Service online shop:

[www.migros-service.ch](http://www.migros-service.ch)